	<b>PACKAGED ROOFTOP UNITS</b>	
<b>INSTALLATION, OPERATION, MAINTENANCE</b>	Supersedes 100.50-NOM5 (517)	Form 100.50-NOM5 (917)

035-21979-003

**SERIES 100  
 SINGLE PACKAGED UNITS  
 YPAL DESIGN LEVEL F**



LD19892

**50 THROUGH 65 TONS**



Issue Date:  
 September 28, 2017



# IMPORTANT!

## READ BEFORE PROCEEDING!

### GENERAL SAFETY GUIDELINES

This equipment is a relatively complicated apparatus. During rigging, installation, operation, maintenance, or service, individuals may be exposed to certain components or conditions including, but not limited to: heavy objects, refrigerants, materials under pressure, rotating components, and both high and low voltage. Each of these items has the potential, if misused or handled improperly, to cause bodily injury or death. It is the obligation and responsibility of rigging, installation, and operating/service personnel to identify and recognize these inherent hazards, protect themselves, and proceed safely in completing their tasks. Failure to comply with any of these requirements could result in serious damage to the equipment and the property in

which it is situated, as well as severe personal injury or death to themselves and people at the site.

This document is intended for use by owner-authorized rigging, installation, and operating/service personnel. It is expected that these individuals possess independent training that will enable them to perform their assigned tasks properly and safely. It is essential that, prior to performing any task on this equipment, this individual shall have read and understood the on-product labels, this document and any referenced materials. This individual shall also be familiar with and comply with all applicable industry and governmental standards and regulations pertaining to the task in question.

---

### SAFETY SYMBOLS

The following symbols are used in this document to alert the reader to specific situations:



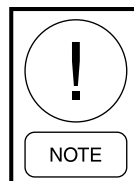
*Indicates a possible hazardous situation which will result in death or serious injury if proper care is not taken.*



*Identifies a hazard which could lead to damage to the machine, damage to other equipment and/or environmental pollution if proper care is not taken or instructions are not followed.*



*Indicates a potentially hazardous situation which will result in possible injuries or damage to equipment if proper care is not taken.*



*Highlights additional information useful to the technician in completing the work being performed properly.*



*External wiring, unless specified as an optional connection in the manufacturer's product line, is not to be connected inside the control cabinet. Devices such as relays, switches, transducers and controls and any external wiring must not be installed inside the micro panel. All wiring must be in accordance with Johnson Controls' published specifications and must be performed only by a qualified electrician. Johnson Controls will NOT be responsible for damage/problems resulting from improper connections to the controls or application of improper control signals. Failure to follow this warning will void the manufacturer's warranty and cause serious damage to property or personal injury.*

## CHANGEABILITY OF THIS DOCUMENT

In complying with Johnson Controls' policy for continuous product improvement, the information contained in this document is subject to change without notice. Johnson Controls makes no commitment to update or provide current information automatically to the manual or product owner. Updated manuals, if applicable, can be obtained by contacting the nearest Johnson Controls Service office or accessing the Johnson Controls QuickLIT website at <http://cgproducts.johnsoncontrols.com>.

It is the responsibility of rigging, lifting, and operating/service personnel to verify the applicability of these documents to the equipment. If there is any question

regarding the applicability of these documents, rigging, lifting, and operating/service personnel should verify whether the equipment has been modified and if current literature is available from the owner of the equipment prior to performing any work on the chiller.

### CHANGE BARS

Revisions made to this document are indicated with a line along the left or right hand column in the area the revision was made. These revisions are to technical information and any other changes in spelling, grammar or formatting are not included.

---

## ASSOCIATED LITERATURE

MANUAL DESCRIPTION	FORM NUMBER
Shipping Damage Claims	50.15-NM
Static Pressure Probe Installation Instructions	100.50-N15
High Altitude Accessory Kit Installation Instructions	100.50-N16
Start-Up Guide	100.50-SU5

# NOMENCLATURE

## BASE MODEL NUMBER

### EXAMPLE -YPAL050NCE46LSFX

<u>1</u>	<u>2</u>	<u>3</u>	<u>4</u>	<u>5</u>	<u>6</u>	<u>7</u>	<u>8</u>	<u>9</u>	<u>10</u>	<u>11</u>	<u>12</u>	<u>13</u>	<u>14</u>	<u>15</u>	<u>16</u>	<u>17</u>	
BASE PRODUCT TYPE				NOMINAL CAPACITY			APPLICATION		REFRIGERANT	VOLTAGE		DUCT LOCATIONS		DESIGN	SPECIAL	GAS HEAT CAPACITY	
Y : YORK				L : Scroll			C : Constant Volume		B : R-407C	2	5	B : Bottom Return		F : Revision Level F (initial)	A : Std. Product, Simplicity Elite B : Special Product, Simplicity Elite X : Std. Product, IPU S : Special Product, IPU	N : No Gas Heat L : Low (375 MBH) M : Med (750 MBH) H : High (1125 MBH)	
A : Air-Cooled				0 5 0			V : VAV, VFD		C : R-22	2	5	R : Rear Return					
P : Packaged Rooftop				0 6 1			F : FlexSys		E : R-410A	4	6	S : Side Return					
				0 6 0						4	8						
				0 6 1						4	0						
							C : Cooling Only			4	5						
							N : Staged Natural Gas Heat			5	8						
							G : Staged Natural Gas Heat SS HX			4	0						
							M : Full Modulating Gas Heat			4	5						
							F : Full Modulating Gas Heat SS Staged HX			4	0						
							E : Electric Heat			4	5						
							H : Hot Water Heat			4	5						
							S : Steam Heat			4	5						

## TABLE OF CONTENTS

<b>SECTION 1 – INTRODUCTION</b> .....	<b>15</b>
Ecological And Economical Design .....	15
Cooling and Heating.....	15
Indoor Air Quality (IAQ).....	15
Premium-Efficiency Motors .....	15
Modulating Gas Heat.....	15
Power Phase Monitor .....	15
Condensing Section .....	15
Scroll Compressors .....	15
Multiple Compressor Staging .....	16
Compressor Circuiting .....	16
Compressor Sound Blankets.....	16
Replaceable Core Filter Driers .....	16
Low Ambient Operation .....	16
Condenser Fan Motors.....	16
Condenser Coils .....	16
Condenser Coil Protection .....	16
Hot Gas Reheat.....	16
Heating Section .....	16
Gas Heat Design And Control Options.....	16
Staged Gas Heat.....	16
Electric .....	16
Air Management .....	16
DWDI Airfoil Fans .....	17
Building Pressure Control.....	17
Low Sound Options .....	17
Variable Frequency Drives .....	17
Fan Spring Isolation .....	17
Controls .....	17
Rooftop Controller.....	17
BACnet .....	17
Indoor Air Quality .....	17
Double Sloped Stainless Steel Drain Pan .....	17
Gas Heat Section .....	17
Double Wall Construction .....	17
Factory Shrinkwrap .....	17
Demand Ventilation Option.....	18
Smoke Purge.....	18
Filtration.....	18
Electrical.....	18
Single Point Power .....	18
Dual Point Power.....	18
Unit-Mounted Disconnect .....	18
Service And Installation .....	18
Access Doors .....	18
Service Valves.....	18
Convenience Outlet.....	18
Factory Run-Tested .....	18
Gas Heat Sections .....	18
Replaceable Core Filter Drier Option .....	18

## TABLE OF CONTENTS (CONT'D)

<b>SECTION 2 – INSTALLATION</b> .....	<b>19</b>
Approvals .....	19
Limitations .....	19
Unit Inspection.....	19
Locations And Clearances.....	19
General.....	19
Location.....	20
Rigging And Handling.....	20
Unit Weights .....	23
Unit Placement.....	28
Roof Curb Installation.....	28
Physical Data .....	29
Electrical Data .....	39
Electrical Service Sizing.....	39
Filters.....	41
Condensate Drain .....	42
Condensate Drain Piping .....	42
Condensate Drain Trap.....	42
Air Hoods For Economizer .....	42
Air Hoods For Fixed Outside Air (Units Without Economizer).....	42
Air Hoods For Exhaust Air.....	42
Field Wiring .....	42
Thermostat.....	42
Space Sensor.....	43
CO <sub>2</sub> Sensor .....	43
Occupied/Unoccupied Input.....	43
Shutdown Input .....	43
Smoke Purge Input.....	43
VAV Heat Relay Output.....	43
Return Air Bypass Damper.....	44
BACnet COMMUNICATION .....	44
Dirty Filter Switch .....	44
Alarm Contacts.....	44
Power Wiring .....	44
Electrical Service Sizing.....	47
Controls.....	51
Transducer Pneumatic Tubing.....	51
Static Pressure Control Plastic Tubing (Pneumatic Tubing).....	51
Duct Static Transducer .....	51
Building Pressure Transducer .....	51
Static Pressure Probe Installation .....	51
Duct System .....	53
Duct Connection Guidelines.....	53
Sound And Vibration Transmission.....	53
Gas Heating .....	54
Gas Piping.....	54
Gas Connection.....	54
Combustion Vent.....	55

## TABLE OF CONTENTS (CONT'D)

<b>SECTION 3 – START-UP</b> .....	<b>57</b>
Crankcase Heaters.....	57
Checking The System Prior To Initial Start (No Power).....	57
Unit Checks.....	57
Unit Checks – Power Applied.....	58
Verifying Compressor Rotation.....	59
Compressor Oil Level Check.....	59
Initial Start-Up.....	59
Refrigerant Charge.....	59
Checking Superheat and Subcooling.....	60
Subcooling (R-410a).....	60
Superheat (R-410a).....	60
Leak Checking.....	60
Gas Heat Models.....	62
Manifold Pressure – Modulating Gas.....	64
Manifold Pressure – Staged Gas.....	64
Manifold Gas Pressure Adjustment.....	64
<b>SECTION 4 – MAINTENANCE</b> .....	<b>67</b>
General.....	67
Periodic Maintenance – Monthly.....	67
Filters.....	67
Linkages.....	67
Compressors.....	67
Fan Bearing Lubrication.....	67
Recommended Lubricant For Fan Bearings.....	67
Condenser Coils.....	68
Periodic Maintenance – Three To Six Months.....	68
Motor Bearing Lubrication.....	68
Belt Tension.....	68
Periodic Maintenance – Yearly.....	68
Entire Unit Inspection.....	68
Sheave Alignment.....	68
Belts.....	68
Belt Replacement.....	69
Belt Tensioning.....	69
Filter Drier Replacement.....	69
Forward Curved Fans.....	69
Fan Motor.....	70
Fan Shaft Bearings.....	70
Bearing Lock Devices.....	72
Eccentric Type.....	72
Torquing of Set-screws.....	73
<b>SECTION 5 – SEQUENCE OF OPERATION</b> .....	<b>75</b>
Unit Type.....	75
Occupancy/unoccupancy determination.....	75
Current Operating Mode.....	75
Constant Volume Mode.....	75

## TABLE OF CONTENTS (CONT'D)

Single Zone VAV (SZVAV).....	76
Variable Air Volume (VAV).....	76
Active Mode Determination.....	76
Constant Volume.....	77
Single Zone VAV.....	78
Variable Air Volume.....	78
Supply Fan Operation.....	79
Supply Fan Proving Circuit.....	79
Constant Volume.....	79
Single Zone VAV.....	79
Variable Air Volume.....	80
Active Supply Air Temperature Setpoints.....	82
Constant Volume: Staged (Thermostat or a BAS Command).....	82
Constant Volume: Zone Temperature Sensor (Hardwired or Communicated from a BAS).....	82
Single Zone VAV.....	83
Variable Air Volume.....	84
Compressor Control.....	86
Compressor Control (CV, SZVAV, and VAV).....	86
Compressor Operation with Economizer.....	86
Compressor Staging.....	86
Fast Compressor Start.....	86
Compressor Staging Logic.....	86
Current Stage.....	87
Changing Staging Sequences.....	87
Compressor Status and Run Data.....	87
Compressor Run Data.....	87
Compressor Status.....	87
Compressor Safety Circuit.....	88
Compressor Safety Circuit: Safety Trips and Safety Lockouts.....	88
Suction Temperature Monitoring.....	89
High Discharge Pressure Unloading.....	90
Low Ambient Operation.....	90
Hot Gas Reheat (SZVAV and VAV Only).....	90
HGRH System.....	90
HRGH 3-Way Stepper Valve.....	91
HGRH Control Board.....	91
HGRH Bleed Solenoid Valve.....	93
HGRH Set-Up.....	93
HGRH Status.....	93
HGRH Sequence of Operation.....	94
HGRH Faults.....	95
Condenser Fan Control.....	96
Ambient Control.....	96
Ambient Plus Discharge Pressure Control.....	96
Economizer.....	96
Dry Bulb.....	96
Single Enthalpy.....	96
Dual Enthalpy.....	97
Best Method.....	97
Heating Operation.....	97
Electric Heat.....	97



## TABLE OF CONTENTS (CONT'D)

Staged Gas Heat.....	99
Modulating Gas Heat.....	100
Gas Heating Furnace Multi-Plexer Board .....	103
Hot Water/Steam Heat .....	104
Morning Warm-Up .....	105
Adaptive Morning Warm-Up .....	106
Supply Air Tempering .....	107
Ventilation.....	108
Damper Hardware.....	108
Control Options .....	108
Ventilation System Active .....	108
2-Position Damper.....	108
Standard Damper .....	108
TEK-Air Full IAQ (Air Measuring Station).....	109
Continuous Ventilation.....	111
Comfort Ventilation .....	111
Exhaust Fan/Return Fan System .....	112
Exhaust Fan/Return Fan Proving Switch .....	112
Exhaust Fan .....	113
Return Fan .....	114
Flexsys Operation .....	116
Factory Recommended Setpoints .....	116
Flexsys: Current Operating Mode (Occupied).....	116
Flexsys: Fan Operation .....	117
Flexsys: Cooling .....	117
Flexsys: Compressor Control.....	118
Flexsys: Heating.....	119
Flexsys: Underfloor Temperature Control.....	119
Flexsys: All Other Sequences .....	120
Smoke Purge.....	120
Smoke Purge Sequences.....	120
Purge Mode.....	120
Pressurization Mode.....	120
Evacuation Mode.....	120
<b>SECTION 6 – USER INTERFACE CONTROL CENTER.....</b>	<b>121</b>
User Interface Control Center .....	121
Data Entry Keys .....	121
Navigation Keys .....	122
Menu Select Keys .....	122
Setpoints .....	136
Program.....	136
Options .....	136
Date / Time .....	137
Schedule .....	137
Operating Hours / Start Counter.....	138
Print .....	139
Service .....	139
History .....	149
Password.....	150
Power Up Banner .....	151

## TABLE OF CONTENTS (CONT'D)

Communication .....	151
Communication Ports .....	151
BACnet Wiring .....	151
Device Object Instance (DE) .....	151
Additional Settings .....	152
<b>SECTION 7 – PARAMETER DESCRIPTIONS AND OPTIONS .....</b>	<b>171</b>
<b>SECTION 8 – SERVICE .....</b>	<b>181</b>
Analog Input Operation .....	181
Temperature Sensors .....	181
Duct Pressure Transducer .....	181
Building Pressure Transducer .....	182
Return Fan Pressure Transducer .....	182
Discharge Pressure Transducer .....	183
Suction Pressure Transducer .....	183
Humidity Sensors .....	183
CO <sub>2</sub> Sensor .....	183
Furnace Status Input .....	184
Faults .....	186
Multi Media Card .....	197

## LIST OF FIGURES

<b>FIGURE 1</b> - Packaged Rooftop Air Conditioning Unit .....	15
<b>FIGURE 2</b> - Unit Clearances .....	20
<b>FIGURE 3</b> - Lifting Lug Locations.....	21
<b>FIGURE 4</b> - Warning Label.....	22
<b>FIGURE 5</b> - Lifting Lug Safe Working Load.....	22
<b>FIGURE 6</b> - Location And Dimension Drawing / 050-061 Models, Bottom Supply / Bottom Return, Standard Cabinet.....	32
<b>FIGURE 7</b> - Location And Dimension Drawing / 050-061 Models, Bottom Supply / Side Return, Standard Cabinet .....	33
<b>FIGURE 8</b> - Location And Dimension Drawing / 050-061 Models, Side Supply / Rear Return, Standard Cabinet .	34
<b>FIGURE 9</b> - Location And Dimension Drawing, / 050-061 Models, Bottom Supply / Bottom Return, Extended Cabinet .....	35
<b>FIGURE 10</b> - Location And Dimension Drawing / 050-061 Models, Bottom Supply / Side Return, Extended Cabinet .....	36
<b>FIGURE 11</b> - Location And Dimension Drawing / 050-061 Models, Side Supply / Rear Return, Extended Cabinet.....	37
<b>FIGURE 12</b> - Curb Layout Drawing / 050-061 Models, Standard And Extended Cabinet.....	38
<b>FIGURE 13</b> - Drain Trap Showing Water Location During Draw Through Operation Stages.....	41
<b>FIGURE 14</b> - Trap Detail For Draw Through Application.....	42
<b>FIGURE 15</b> - Field Control Wiring - Inputs .....	45
<b>FIGURE 16</b> - Field Control Wiring - Outputs .....	46
<b>FIGURE 17</b> - Single-Point Power Supply Wiring .....	48
<b>FIGURE 18</b> - Single-Point Power Supply Wiring With Non-Fused Disconnect .....	49
<b>FIGURE 19</b> - Dual-Point Power Supply Wiring.....	50
<b>FIGURE 20</b> - Atmospheric Sensor Probe.....	52
<b>FIGURE 21</b> - Discharge And Return Air Openings.....	53
<b>FIGURE 22</b> - Typical Gas Piping Connection.....	54
<b>FIGURE 23</b> - Combustion Vent .....	55
<b>FIGURE 24</b> - Fan Hold Down Brackets.....	58
<b>FIGURE 25</b> - Manifold Gas Pressure Adjustment .....	65
<b>FIGURE 26</b> - Sheave Alignment.....	68
<b>FIGURE 27</b> - Belt Tensioning Gauge.....	69
<b>FIGURE 28</b> - Example of FC Fan Shaft/Wheel Marking .....	69
<b>FIGURE 29</b> - Bearing With Setscrew Type Locking Device .....	70
<b>FIGURE 30</b> - Eccentric Cam Locking Collar Bearing Installation .....	71
<b>FIGURE 31</b> - Bearing With Eccentric Cam.....	72
<b>FIGURE 32</b> - Split Bearing .....	73
<b>FIGURE 33</b> - Operational Mode (Space Sensor Input) .....	77
<b>FIGURE 34</b> - Operational Mode: Single Zone VAV .....	78
<b>FIGURE 35</b> - Operational Mode: VAV .....	79
<b>FIGURE 36</b> - Active DSP Setpoint vs. Duct Static Pres Rst Voltage.....	81
<b>FIGURE 37</b> - Active SAT Setpoint vs. Supply Air Temp Rst Voltage .....	84
<b>FIGURE 38</b> - Active SAT Setpoint vs. Outside Air Temp .....	84
<b>FIGURE 39</b> - Active SAT Setpoint vs. Return Air Temp .....	85
<b>FIGURE 40</b> - Active SAT Setpoint vs. Supply Fan Speed .....	85
<b>FIGURE 41</b> - HGRH 3-Way Stepper Valve.....	91
<b>FIGURE 42</b> - Max HGRH Valve Position vs. OAT .....	91
<b>FIGURE 43</b> - HGRH Control Board.....	92
<b>FIGURE 44</b> - HGRH Piping Layout .....	93
<b>FIGURE 45</b> - Supply Air Dew Point Active Setpoint vs. Return Air Humidity.....	94
<b>FIGURE 46</b> - HGRH SAT Active Setpoint vs. Return Air Temperature .....	95
<b>FIGURE 47</b> - Digital Multi-Plexer Connections: Staged Gas Heat .....	100
<b>FIGURE 48</b> - Digital Multi-Plexer Connections: Modulating Gas Heat.....	102
<b>FIGURE 50</b> - Gas Heating Furnace Multi-Plexer Board (Staged and Modulating Gas Heat).....	103

## LIST OF FIGURES (CONT'D)

<b>FIGURE 49</b> - Modulating Gas Heat Staging Sequence.....	103
<b>FIGURE 51</b> - TEK-Air Probe and Transducer.....	109
<b>FIGURE 52</b> - TEK-Air Monitor .....	110
<b>FIGURE 53</b> - TB7 Terminal Strip .....	112
<b>FIGURE 54</b> - Relay 2.....	113
<b>FIGURE 55</b> - Exhaust Fan Assembly .....	113
<b>FIGURE 56</b> - Return Fan Assembly .....	115
<b>FIGURE 57</b> - Active Return Plenum Pressure Setpoint vs. Exhaust Output .....	116
<b>FIGURE 58</b> - User Interface Control Panel .....	121
<b>FIGURE 59</b> - IPU Control Board.....	152
<b>FIGURE 60</b> - I/O Control Board.....	187
<b>FIGURE 61</b> - I/O Control Board - Binary Outputs.....	188
<b>FIGURE 62</b> - I/O Control Board - Binary Inputs.....	189
<b>FIGURE 63</b> - I/O Control Board - Analog Outputs.....	189
<b>FIGURE 64</b> - I/O Control Board - Analog Inputs.....	189

## LIST OF TABLES

<b>TABLE 1</b> - Voltage Limitations .....	19
<b>TABLE 2</b> - Lifting Lug Locations.....	21
<b>TABLE 3</b> - Unit Weights - 050-061 Models .....	23
<b>TABLE 4</b> - Unit Center Of Gravity And Corner Loads .....	25
<b>TABLE 5</b> - Unit Corner Weights - 050-061 Models .....	27
<b>TABLE 6</b> - Physical Data – 050-061 Models.....	29
<b>TABLE 7</b> - Physical Data - Compressors.....	31
<b>TABLE 8</b> - Compressor Data - R-410A .....	39
<b>TABLE 9</b> - Power Supply Voltage Limits.....	39
<b>TABLE 10</b> - Condenser Fan Motor RLA - Standard Fan.....	40
<b>TABLE 11</b> - Condenser Fan Motor RLA - Low Sound Fan (Future Option).....	40
<b>TABLE 12</b> - Supply And Exhaust Fan Motor Data - ODP .....	40
<b>TABLE 13</b> - Supply And Exhaust Fan Motor Data - TEFC.....	40
<b>TABLE 14</b> - Miscellaneous Electrical Data.....	40
<b>TABLE 15</b> - Electric Heat .....	41
<b>TABLE 16</b> - Airflow And Entering Air/Ambient Limitations.....	41
<b>TABLE 17</b> - Three Phase Power Supply Conductor Size Range 050-061 Models.....	51
<b>TABLE 18</b> - Supply Air Duct Connection Configurations.....	53
<b>TABLE 19</b> - Return Air Duct Connection Configurations.....	53
<b>TABLE 20</b> - Pipe Sizes.....	54
<b>TABLE 21</b> - Condenser Coil Pressure Drop.....	59
<b>TABLE 22</b> - R410-A Pressure / Temperature Chart .....	61
<b>TABLE 23</b> - Low Fire (Inducer Fan On Low, 1.4 "W.C. Input To Maxitrol Valve .....	64
<b>TABLE 24</b> - High Fire (Inducer Fan On High, 3.5 "W.C. Input To Maxitrol Valve .....	64
<b>TABLE 25</b> - Low Fire / High Fire Pressures .....	64
<b>TABLE 26</b> - Gas Heat Performance Data .....	65
<b>TABLE 27</b> - Fan Bearing – Lubrication Intervals.....	67
<b>TABLE 28</b> - Set Screw Torque .....	72
<b>TABLE 29</b> - CV: Operational Mode (Staged input).....	77
<b>TABLE 30</b> - Supply Fan VFD Speed Determination .....	80
<b>TABLE 31</b> - Active SAT Setpoint Determination, Staged Input .....	82
<b>TABLE 32</b> - Active SAT Setpoint Determination, Zone Temperature .....	83
<b>TABLE 38</b> - Input Signal (Jumper Location).....	92

## LIST OF TABLES (CONT'D)

<b>TABLE 39</b> - Number of Steps.....	92
<b>TABLE 40</b> - Valve Type .....	92
<b>TABLE 33</b> - One Compressor On Per Any System.....	96
<b>TABLE 34</b> - Two Compressor On Per Any System.....	96
<b>TABLE 35</b> - Staged Input SAT Heating Setpoint.....	98
<b>TABLE 36</b> - Zone Temperature heating Setpoints .....	98
<b>TABLE 37</b> - TEK-Air Monitor Settings .....	110
<b>TABLE 41</b> - Status .....	123
<b>TABLE 42</b> - Unit Data.....	124
<b>TABLE 43</b> - Cooling .....	125
<b>TABLE 44</b> - Compressor Systems (1, 2, or 3).....	127
<b>TABLE 45</b> - Supply System.....	129
<b>TABLE 46</b> - Heating .....	130
<b>TABLE 47</b> - Economizer.....	133
<b>TABLE 48</b> - Ventilation.....	134
<b>TABLE 49</b> - Exhaust.....	135
<b>TABLE 50</b> - Operating Hours / Start Counter.....	138
<b>TABLE 51</b> - Service.....	139
<b>TABLE 52</b> - BACnet MS/TP, MODBUS, BACnet IP .....	153
<b>TABLE 53</b> - Definitions.....	171
<b>TABLE 54</b> - Temperature Sensor Resistance .....	181
<b>TABLE 55</b> - Duct Pressure Transducer.....	182
<b>TABLE 56</b> - Building Pressure Transducer Output.....	182
<b>TABLE 57</b> - Return Fan Pressure Transducer Output .....	183
<b>TABLE 58</b> - Pressure Transducers .....	183
<b>TABLE 59</b> - Humidity Sensor Outputs.....	184
<b>TABLE 60</b> - CO2 Sensor Output.....	184
<b>TABLE 61</b> - Furnace Status Input Modulating Gas Heat .....	185
<b>TABLE 62</b> - Furnace Status Input Staged Gas Heat.....	185
<b>TABLE 63</b> - I/O Control Board - Analog Input Pin Outs.....	190
<b>TABLE 64</b> - Warning Description Table.....	191
<b>TABLE 65</b> - Fault Auto - Reset.....	193
<b>TABLE 66</b> - Faults Lockout .....	195
<b>TABLE 67</b> - Data Log Error State.....	197
<b>TABLE 68</b> - Data Log Error Log Detail.....	198

THIS PAGE INTENTIONALLY LEFT BLANK

## SECTION 1 – INTRODUCTION

### ECOLOGICAL AND ECONOMICAL DESIGN

High Efficiency Series 100 Packaged Rooftop Units are optimized for HFC-410A refrigerant. Johnson Controls provides the FIRST standard product offering that meets the latest ASHRAE 90.1 energy efficiency requirements.

#### Cooling and Heating

Superior operating performance provides lower operating costs. Smaller steps of cooling capacity provide tighter control of building environment and occupant comfort while optimizing energy efficiency.

#### Indoor Air Quality (IAQ)

Outside air economizers provide energy savings in free cooling mode, and can provide a healthier and more comfortable building environment by introducing fresh outside air into the building as needed. Indoor Air Quality (IAQ) requirements for building ventilation and comfort are controlled through the microprocessor control panel. Optional airflow measurement provides an accurate means of tracking air quality and alerting the occupants or building owner to unhealthy situations.

#### Premium-Efficiency Motors

Premium-efficiency motors are available for optimum energy efficiency. All motors used on the Series 100 Packaged Rooftop air conditioner meet U.S. EPACKT 1992 minimum requirements.

High-efficiency motors are standard. Motors are available in ODP or TEFC construction.

#### Modulating Gas Heat

Fully modulating gas heat and greater steps of capacity control offer superior off-design performance while maintaining optimum occupant comfort.

#### Power Phase Monitor

Series 100 units ordered as Single Point Power will have a power phase monitor standard. The power phase monitor will help protect the unit from certain electrical issues such as phase loss, phase imbalance, and high and low voltage.

### CONDENSING SECTION

#### Scroll Compressors

Reliable, efficient, trouble-free operation is the true measure of a Packaged Rooftop's value. That's why Series 100 Packaged Rooftop air conditioners use established scroll-compressor technology to deliver dependable, economical performance in a wide range of applications. With the Packaged Rooftop Unit, you get the latest generation of compressor enhancements added to the scroll's inherent strengths. The simplicity of a hermetic scroll compressor allows the use of fewer moving parts to minimize breakdown.



LD13271

**FIGURE 1 - PACKAGED ROOFTOP AIR CONDITIONING UNIT**

## Multiple Compressor Staging

Through the use of the scroll compressor, the Series 100 has the ability to stage its cooling by enabling and disabling multiple single stage compressors on multiple circuits. These compressors are manifolded together in two independent circuits.

## Compressor Circuiting

The Series 100 is designed so that only two scroll compressors are in tandem within one refrigeration circuit. This means more reliable compressors, and less equipment down time. With multiple circuits, if a compressor should ever fail on one circuit, the other circuits will remain operational to work to maintain occupied loads. The Series 100 system has two circuits in the unit.

## Compressor Sound Blankets

Optional factory installed sound blankets can be installed to further reduce compressor sound attenuation.

## Replaceable Core Filter Driers

The optional replaceable core filter drier on the Packaged Rooftop Unit provides a convenient means for maintaining and optimizing the unit's refrigeration system. Eliminating additional field penetrations into the refrigerant circuit, which could lead to potential problems, reduce the worry of refrigerant circuit contamination.

## Low Ambient Operation

Head-pressure control is accomplished via a VFD motor controller rather than an inefficient and noisy condenser fan damper. By varying the speed of the condenser fan, better control and quieter operation is obtained during the colder months. Low ambient controls are available on all systems offering higher rooftop cooling capacity than competitive units.

## Condenser Fan Motors

The condenser fan motors used on the Packaged Rooftop Unit are Totally Enclosed Air Over (TEAO) to provide maximum durability through any season.

## Condenser Coils

Condenser coils are available in various materials and coatings to suit almost any type of application. Aluminum or copper fins, pre-coated or post-coated fins are available. The coating is applied using an epoxy coating on the aluminum coil. Each coil option is beneficial

when the unit must operate under extreme conditions. The use of an epoxy coated coil is recommended for units installed in a corrosive environment.

## Condenser Coil Protection

The Series 100 is available with a wire mesh guard for optimum coil protection.

## Hot Gas Reheat

The Series 100 50-65 ton unit has the option to order a Hot Gas Reheat System (HGRH). The HGRH will be used to help with dehumidification of the space. HGRH is only available on Single Zone VAV and Variable Air Volume configured units.

## HEATING SECTION

### Gas Heat Design And Control Options

Includes an unsurpassed 24:1 turndown modulating gas furnace, and staged heating control. A Staged furnace is also available that allows up to six stages of capacity.

### Staged Gas Heat

The rooftop gas furnace is an induced-draft gas furnace designed for high efficiency and reliability. The furnace uses an aluminized steel tubular heat exchanger and operates at temperatures sufficient to prevent acidic exhaust gases from condensing in the heat exchanger at low fire rates, unlike drum and tube style furnaces that generate condensation formation. An optional stainless steel heat exchanger is also available.

### Electric

The Series 100 is also available with an electrical heater that can range from 40kW up to 160kW. Depending on the size of the heat required, the Series 100 can have two to four steps of control helping to provide tighter control of the supply and zone conditioned air. With the utilization of this multi-step function, the Series 100 can effectively reduce energy consumption by bringing on smaller stages of heat while maintaining the maximum level of comfort.

## AIR MANAGEMENT

The YORK FlexSys Underfloor Air system provides a cutting edge, cost competitive alternative to conventional overhead air distribution systems based on the performance and system flexibility benefits that it can provide. When combined with a Packaged Rooftop Unit, the system offers a completed package that provides an optimum solution for building comfort control.



FlexSys technology uses the open space between the structural concrete slab and the underside of a raised access floor system to deliver conditioned air directly into the occupied zones of office and other commercial buildings. This underfloor plenum incorporates the air distribution system with the building power, telecom, and data cabling in one easily accessed service plenum.

The raised access floor concept is a proven design ideal for office buildings that house today's modern business that relies on critical information technologies to maintain high productivity levels. The unmatched flexibility offered by raised floor systems allows for significant costs savings and reduced downtimes when a fast-paced economy demands office space reconfiguration.

### **DWDI Airfoil Fans**

High efficiency fans are used to improve application flexibility, and address sound and application concerns.

### **Building Pressure Control**

Return fans, exhaust fans, and barometric relief dampers are available to meet building pressure control requirements. Select the most appropriate option for a given application.

### **Low Sound Options**

Allow for application of the Packaged Rooftop Unit in sound-sensitive applications such as theaters and downtown areas. Contact Johnson Controls for more details on site-specific requirements.

### **Variable Frequency Drives**

When a Single Zone VAV or VAV unit is ordered, the Packaged Rooftop Unit comes standard with variable frequency drives (VFDs). The VFD can optimize a systems performance by modulating the supply fan motor speed to reduce energy consumption by as much as 40% while maximizing occupant comfort.

### **Fan Spring Isolation**

Two-inch spring isolation is used to prevent vibration transmission from the rooftop unit's supply fan to the building.

## **CONTROLS**

### **Rooftop Controller**

The ColdFire™ processor-based controller uses the latest in processor technology to provide the highest level of rooftop control with BACnet open protocol communication capabilities. An 80-character display and keypad are standard for simple, and easy to understand manipulation of control setpoints and readout of operating parameters and diagnostics. Shutdown and alarm faults are all recorded in memory, and include a time and day stamp for easy troubleshooting.

### **BACnet**

The Series 100 can be adapted to operate with any building automation system that is BACnet compatible making it the most flexible large commercial rooftop units on the market.

## **INDOOR AIR QUALITY**

### **Double Sloped Stainless Steel Drain Pan**

The Series 100's standard Stainless Steel drain pan meets ASHRAE 62 requirements for condensate drainage to improve indoor air quality. Solid wall liners encase insulation and prevent moisture damage. Additional benefits include easy cleanability and isolates insulation from conditioned airstream.

### **Gas Heat Section**

Factory wired and leak checked.

### **Double Wall Construction**

Included in standard construction of the Packaged Rooftop Unit and incorporates powder coated pre-fabricated outer panels and corner post for maximum exterior surface protection.

### **Factory Shrinkwrap**

All Series 100 Rooftop Units can be ordered from the factory with an optional factory-fresh shrinkwrap packaging. This eliminates the contractors worries about dirt and debris clogging up condenser coils or moisture leaking into the air handler on the units way to the job site or rigging yard.

## **Demand Ventilation Option**

Can be incorporated into the unit to improve indoor air quality and help manage indoor pollutants such as CO<sub>2</sub> or other harmful airborne contaminants out of the occupied spaces for maximum comfort and safety. Activation of this sequence can easily be accomplished using CO<sub>2</sub> sensors installed in the unit. The rooftop unit controller includes two analog inputs for sensors to sense indoor and/or outdoor CO<sub>2</sub> levels to maintain optimum occupant comfort and safety. CO<sub>2</sub> sensors are typically used with demand ventilation; however other sensors may be applied to control indoor contaminants such as volatile organic compounds (VOCs).

## **Smoke Purge**

Is also available through the User Interface to evacuate smoke due to fire from a room or zone.

## **Filtration**

The Series 100 is configured for various types of filtration to meet the different needs and requirements of today's rooftop applications, including 2-inch throw-away, pleated, carbon, and cleanable filters and 12-inch high efficiency rigid filters.

## **ELECTRICAL**

### **Single Point Power**

The Packaged Rooftop Unit comes standard with single point power connections to make installation quick and easy.

### **Dual Point Power**

Can be factory installed for applications that require the mechanical heating and cooling functions to be separated from the air handling functions. This enables the unit to be operated in an emergency condition while minimizing power consumption.

## **Unit-Mounted Disconnect**

Is available as an option to minimize time at installation of equipment and to reduce necessary field installed items.

## **SERVICE AND INSTALLATION**

### **Access Doors**

Full-sized access doors provide easy access into the unit for routine maintenance and inspection. An option for “bothside” access is also available.

### **Service Valves**

Oversized service valves to provide isolation and quick reclamation and charging of system refrigerant are available as an option to minimize downtime and simplify the service and repair task.

### **Convenience Outlet**

For maintenance tasks requiring power tools, an optional 110V GFCI power supply can power lights, drills or any other power hand tool needed.

### **Factory Run-Tested**

Each unit is subjected to a series of quality assurance checks as well as an automated quality control process before being run-tested. Fans and drives are balanced at the factory during testing. The factory run-test ensures safe proper operation when the unit is installed, and reduces installation and commissioning time.

### **Gas Heat Sections**

Are factory wired and leak checked.

### **Replaceable Core Filter Drier Option**

Provides a means to remove moisture, dirt and debris from the refrigeration circuit in the event it is opened.

## SECTION 2 – INSTALLATION

### APPROVALS

Designed certified by ETL, CETL as follows:

- For use as a forced air furnace with cooling unit (gas heat models).
- For outdoor installation only.
- For installation on combustible material and may be installed directly on combustible flooring or Class A, Class B or Class C roof covering materials.
- For use with natural gas or LP.
- When used with LP propane gas one of the following conversion kits must be installed before the gas heat section is fired:
  - 375,000 BTU Input - 385-01866-001
  - 750,000 BTU Input - 385-01866-002
  - 1,125,000 BTU Input - 385-01866-003

Not suitable for use with conventional venting systems.

### LIMITATIONS

The installation of this unit must conform to local building codes, or in the absence of local codes, with ANSI Z23.1 Natural Fuel Gas Code and /or CAN/CGA B149 installation codes.

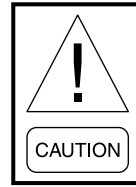
In U.S.A.:

- National Electrical Code ANSI/NFPA No. 70 - Latest Edition.
- National Fuel Gas Code Z223.1 - Latest Edition.
- Gas-Fired Central Furnace Standard ANSI Z21.47 - Latest Edition.
- Local gas utility requirements.

Refer to *Table 16 on page 41* for airflow and entering air/ambient conditions limitations, and *Table 1 on page 19* for voltage limitations.

**TABLE 1 - VOLTAGE LIMITATIONS**

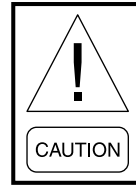
UNIT POWER SUPPLY	VOLTAGE VARIATIONS	
	MIN. VOLTS	MAX. VOLTS
575-3-60	518	632
480-3-60	415	506
230-3-60	207	253
200-3-60	187	228



***If the VAV boxes in the conditioned space have hydronic heating coils installed, it is the responsibility of the installing contractor to take appropriate measures to protect the hydronic coils against low unit supply air temperatures that could result in the freeze up and rupture of the coils.***

### UNIT INSPECTION

Immediately upon receiving the unit, it should be inspected for possible damage, which may have occurred during transit. If damage is evident, it should be noted in the carrier's freight bill. A written request for inspection by the carrier's agent should be made at once. See Shipping Damage Claims Service Policy, Form 50.15-NM, for more information and details.



***To ensure warranty coverage, this equipment must be commissioned and serviced by an authorized Johnson Controls service mechanic or a qualified service person experienced in packaged rooftop installation. Installation must comply with all applicable codes, particularly in regard to electrical wiring and other safety elements such as relief valves, HP cut-out settings, design working pressures, and ventilation requirements consistent with the amount and type of refrigerant charge.***

***Lethal voltages exist within the control panels. Before servicing, open and tag all disconnect switches.***

### LOCATIONS AND CLEARANCES

#### General

The Packaged Rooftop air conditioning units are designed for outdoor installation. When selecting a site for installation, be guided by the following conditions:

- Unit must be installed on a level surface.
- For the outdoor location of the unit, select a place having a minimum sun exposure and an adequate supply of fresh air for the condenser.
- Also avoid locations beneath windows or between structures.
- Optional condenser coil protection should be used for seashore locations or other harsh environments.

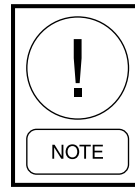
- The unit should be installed on a roof that is structurally strong enough to support the weight of the unit with a minimum of deflection. It is recommended that the unit(s) be installed not more than 15 feet from a main support beam to provide proper structural support and to minimize the transmission of sound and vibration. Ideally, the center of gravity should be located over a structural support or building column.
- Location of unit(s) should also be away from building flue stacks or exhaust ventilators to prevent possible reintroduction of contaminated air through the outside air intakes.
- Be sure the supporting structures will not obstruct the duct, gas or wiring connections.

## LOCATION

Of the many factors that can affect the location of equipment, some of the most important to consider are Structural, Acoustical and Service clearances. Proper attention should be made at the design stage to ensure proper structural support. In cases where equipment is being replaced, be aware of building design to insure support is adequate for the application.

The next most important consideration in applying roof top equipment is that of sound from the equipment. Special care should be made to keep the roof top unit away from sound sensitive areas such as conference rooms, auditoriums and executive offices and any other room that may have potential for tenant occupancy. Possible locations could be above hallways, mechanical or utility rooms.

Finally, service clearances should be maintained in rooftop design to insure safe access to the unit. Unit clearances are designed so that technicians have enough space between units, building walls, and edges of building to gain access safely. In cases where space is limited, please call your local Johnson Controls representative for additional information.



***The clearances shown are to provide adequate condenser airflow and service access to inside the unit. Additional clearance should be considered for component replacement such as compressors, evaporator coils, and supply or exhaust fans.***

***While it is a common practice to operate the fan as soon as possible (air movement during construction) on the job site, the incomplete ductwork and missing diffuser grilles will greatly reduce air resistance and will allow the fan to operate beyond design parameters. This practice may result in water carry over and flooding of the unit. Also, the supply fan motor may overamp and become damaged.***

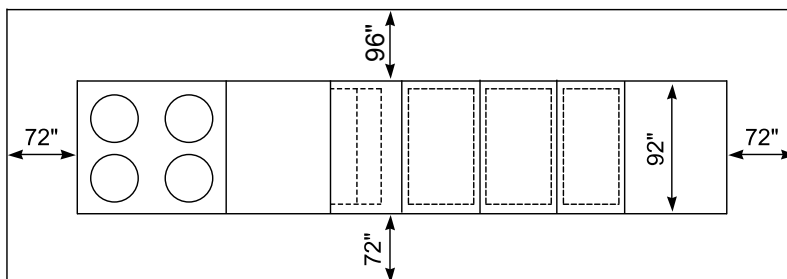
## RIGGING AND HANDLING

Proper rigging and handling of the equipment is mandatory during unloading and setting it into position to retain warranty status. All lifting lugs must be used to prevent twisting and damage to the unit.

Care must be taken to keep the unit in the upright position during rigging and to prevent damage to the watertight seams in the unit casing. Avoid unnecessary jarring or rough handling.

See *Figure 3 on page 21* for number and location of the lifting lugs by unit size. It is also mandatory that an experienced and reliable rigger be selected to handle unloading and final placement of the equipment. The rigger must be advised that the unit contains internal components and that it be handled in an upright position. Care must be exercised to avoid twisting the equipment structure.

Unit weights are listed under *Table 3 on page 23* in this manual. These weights must be referred to when selecting a crane for rigging and figuring roof weight loads. Contact your Johnson Controls Sales Office if you have any questions regarding unit weights.



### NOTES:

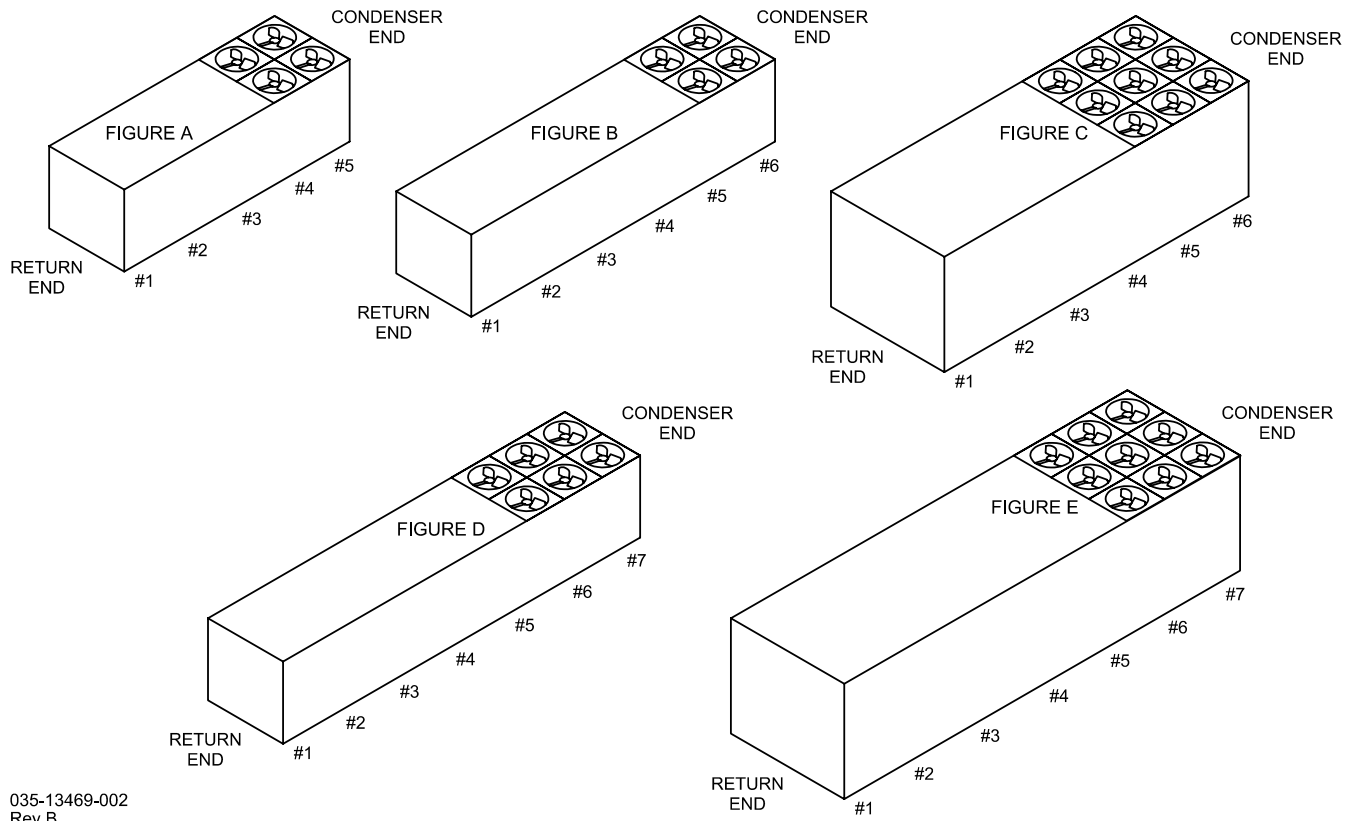
1. 10' clearance minimal over the top of the condensing unit.
2. Only one adjacent wall can exceed unit height.
3. 12' clearance required to adjacent units.
4. 8' service access recommended on one side.
5. Economizer and exhaust hoods, where applicable, are folded inside unit for shipment.
6. Dim. is to outside of lifting lugs.

LD13267A

**FIGURE 2 - UNIT CLEARANCES**


**TABLE 2 - LIFTING LUG LOCATIONS**

See Figure 3 on page 21 For Rigging	Model	Cabinet	Lift Points Dimensions Taken From End Opposite Condenser													
			#1		#2		#3		#4		#5		#6		#7	
			Inch	Metric	Inch	Metric	Inch	Metric	Inch	Metric	Inch	Metric	Inch	Metric	Inch	Metric
A	050	STANDARD	16.9	430	79.3	2015	147.9	3757	207.8	5278	315.0	8802	-	-	-	-
	051	STANDARD	16.9	430	79.3	2015	147.9	3757	207.8	5278	315.0	8802	-	-	-	-
	060	STANDARD	16.9	430	79.3	2015	147.9	3757	207.8	5278	315.0	8802	-	-	-	-
	061	STANDARD	16.9	430	79.3	2015	147.9	3757	207.8	5278	315.0	8802	-	-	-	-
B	050	EXTENDED	16.9	430	79.3	2015	147.9	3757	207.8	5278	254.6	6467	361.9	9191	-	-
	051	EXTENDED	16.9	430	79.3	2015	147.9	3757	207.8	5278	254.6	6467	361.9	9191	-	-
	060	EXTENDED	16.9	430	79.3	2015	147.9	3757	207.8	5278	254.6	6467	361.9	9191	-	-
	061	EXTENDED	16.9	430	79.3	2015	147.9	3757	207.8	5278	254.6	6467	361.9	9191	-	-
C	120	STANDARD	22.8	578	117.6	2981	181.9	4591	239.4	6172	296.3	7526	406.4	10323	-	-
	130	STANDARD	22.8	578	117.6	2981	181.9	4591	239.4	6172	296.3	7526	406.4	10323	-	-
	150	STANDARD	22.8	578	117.6	2981	181.9	4591	239.4	6172	296.3	7526	406.4	10323	-	-
D	070	STANDARD	29.9	759	77.0	1956	197.0	5004	270.5	6871	318.6	8093	373.8	9493	428.9	10894
	070	EXTENDED	29.9	759	77.0	1956	197.0	5004	270.5	6871	381.6	9693	436.8	11093	491.9	12494
	075	STANDARD	29.9	759	77.0	1956	197.0	5004	270.5	6871	318.6	8093	373.8	9493	428.9	10894
	075	EXTENDED	29.9	759	77.0	1956	197.0	5004	270.5	6871	381.6	9693	436.8	11093	491.9	12494
	080	STANDARD	29.9	759	77.0	1956	197.0	5004	270.5	6871	318.6	8093	373.8	9493	428.9	10894
	080	EXTENDED	29.9	759	77.0	1956	197.0	4826	270.5	6871	381.6	9693	436.8	11093	491.9	12491
	090	STANDARD	29.9	759	99.0	2515	190.0	4826	302.5	7684	353.1	8970	408.3	10370	463.4	11770
	090	EXTENDED	29.9	759	99.0	2515	190.0	4826	302.5	7684	422.1	10722	477.3	12122	532.4	13522
	105	STANDARD	29.9	759	99.0	2515	190.0	4826	302.5	7684	353.1	8970	408.3	10370	463.4	11770
	105	EXTENDED	29.9	759	99.0	2515	190.0	4826	302.5	7684	422.1	10722	477.3	12122	532.4	13522
E	120	EXTENDED	22.8	578	117.6	2981	181.9	4591	239.4	6172	307.0	7798	360.3	9151	470.4	11949
	130	EXTENDED	22.8	578	117.6	2981	181.9	4591	239.4	6172	307.0	7798	360.3	9151	470.4	11949
	150	EXTENDED	22.8	578	117.6	2981	181.9	4591	239.4	6172	307.0	7798	360.3	9151	470.4	11949



035-13469-002  
Rev B

**FIGURE 3 - LIFTING LUG LOCATIONS**




# WARNING

Failure to follow these instructions could result in death, serious injury  
or equipment damage.

Follow all warnings and instructions in the unit's Manual(s).

<p><b>EN</b> Installation Instructions for the technician / fitter</p> <p><b>PL</b> Instrukcja instalacji dla technika / monter</p> <p><b>SV</b> Installationsguide för installatör / montör</p> <p><b>CZ</b> Pokyny k instalaci pro techniky a montéry</p>	<p><b>IT</b> Istruzioni d'installazione per il personale specializzato</p> <p><b>NL</b> Installatiehandleiding voor de vakman / monteur</p> <p><b>DE</b> Installationsanleitung für die Fachkraft / Monteur</p> <p><b>ES</b> Instrucciones de instalación para el técnico / contratista especializado</p>	<p><b>JP</b> 一般仕様・取扱説明書</p> <p><b>FR</b> Manuel d'installation pour le spécialiste / monteur</p> <p><b>RU</b> Инструкция по установке для техника/монтажника</p> <p><b>CN</b> 适用于技术人员与安装人员的 安装说明书</p>
---	---	---

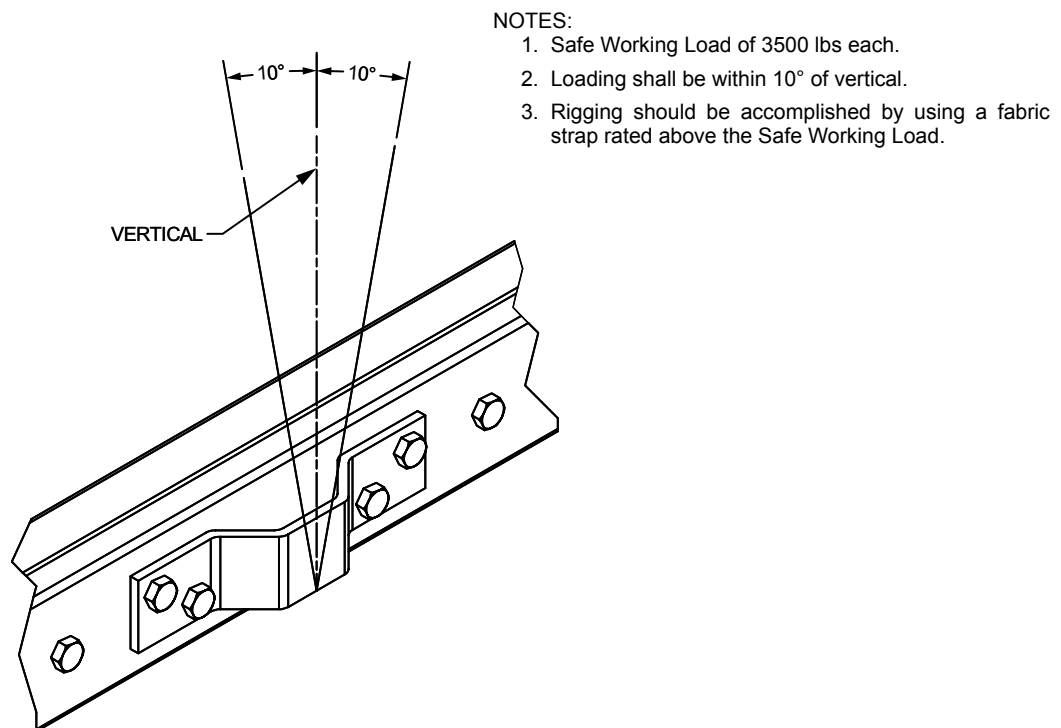


1. Follow all applicable regulations and safety practices during rigging and lifting.
2. Prepare and follow written rigging and lifting plan.
3. Rigging must be directed by trained professional rigger.
4. Spreader bars must be used and be long enough to prevent rigging from contacting unit.
5. Use all and only designated lift points according to units manual(s).
6. Locate center of gravity through trial lifts to account for possible variations in unit configuration.
7. Use rigging and lifting techniques that keep unit stable and level.
8. Keep clear of unit when lifted.

035-23962-000 REV -

LD18108

FIGURE 4 - WARNING LABEL



LD19896

FIGURE 5 - LIFTING LUG SAFE WORKING LOAD

**UNIT WEIGHTS**

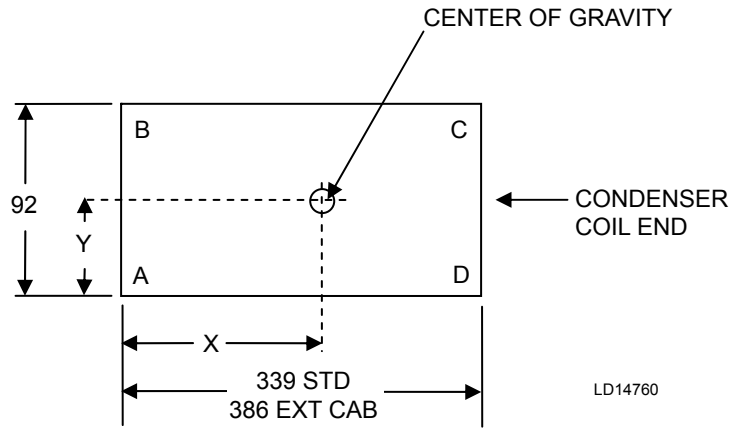
**TABLE 3 - UNIT WEIGHTS - 050-061 MODELS**

MODEL	WEIGHT (LBS)			
	050	051	060	061
BASE UNIT WEIGHT - Standard Cabinet	8650	8650	8941	8960
BASE UNIT WEIGHT - Extended Cabinet	9493	9493	9784	9803
Base unit is cooling only with a class 1 FC supply fan with 20 HP motor, supply fan VFD, 2" throwaway filters, aluminum coils, no condenser guards, no return or exhaust and no economizer.				
COIL OPTIONS				
MODEL	050	051	060	061
Copper Cond Coils	520	520	760	760
Copper Evap Coils	440	440	620	620
SUPPLY FAN OPTIONS				
SUPPLY FAN	050	051	060	061
Supply Fan FC, Class 2	41	41	41	41
Supply Fan AF, Class 2	128	128	128	128
SUPPLY FAN MOTOR	050	051	060	061
Supply Fan Motor - 5 HP	-150	-150	-150	-150
Supply Fan Motor - 7.5 HP	-117	-117	-117	-117
Supply Fan Motor - 10 HP	-93	-93	-93	-93
Supply Fan Motor - 15 HP	-20	-20	-20	-20
Supply Fan Motor - 25 HP	93	93	93	93
Supply Fan Motor - 30 HP	135	135	135	135
Supply Fan Motor - 40 HP	237	237	237	237
SUPPLY FAN VFD	050	051	060	061
Supply Fan VFD - 5 - 10 HP	-29	-29	-29	-29
Supply Fan VFD - 30 - 40 HP	15	15	15	15
FILTER OPTIONS				
MODEL	050	051	060	061
2" Cleanable	0	0	0	0
2" Pleated	0	0	0	0
2" Carbon	0	0	0	0
Rigid Filter - 2" Throwaway - Only	0	0	0	0
Rigid Filter - 12" 60-65%	319	319	319	319
Rigid Filter - 12" 90-95%	319	319	319	319
Final Filters	305	305	305	305

**TABLE 3 - UNIT WEIGHTS - 050-061 MODELS (CONT'D)**

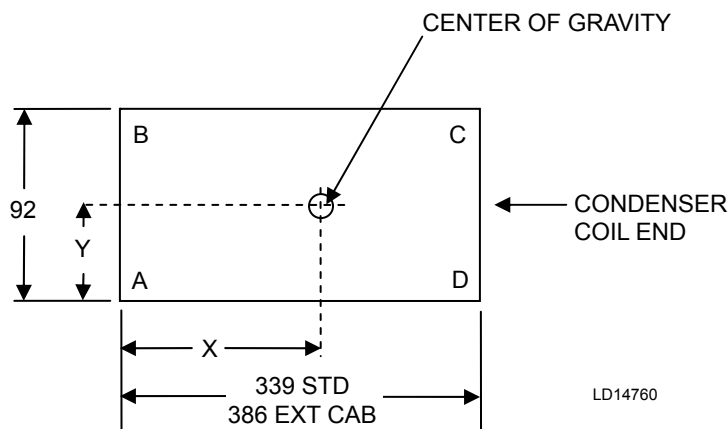
MODEL	WEIGHT (LBS)			
	050	051	060	061
<b>ECONOMIZER / EXHAUST / RETURN FAN OPTIONS</b>				
Economizer	527	527	527	527
<b>EXHAUST-RETURN FAN</b>	<b>050</b>	<b>051</b>	<b>060</b>	<b>061</b>
Exhaust Fan Option	465	465	465	465
Return Fan Option	691	691	691	691
<b>EXHAUST DAMPER</b>	<b>050</b>	<b>051</b>	<b>060</b>	<b>061</b>
Exhaust Damper Barometric	36	36	36	36
Exhaust Damper Modulating	53	53	53	53
<b>EXHAUST-RETURN FAN MOTOR</b>	<b>050</b>	<b>051</b>	<b>060</b>	<b>061</b>
Exhaust Fan Motor - 5hp	87	87	87	87
Exhaust Fan Motor - 7.5hp	120	120	120	120
Exhaust Fan Motor - 10hp	144	144	144	144
Exhaust Fan Motor - 15hp	217	217	217	217
Return Fan Motor - 5 HP	174	174	174	174
Return Fan Motor - 7.5 HP	240	240	240	240
Return Fan Motor - 10 HP	288	288	288	288
Return Fan Motor - 15 HP	434	434	434	434
<b>EXHAUST FAN VFD</b>	<b>050</b>	<b>051</b>	<b>060</b>	<b>061</b>
Exhaust Fan VFD 5 - 10 HP	22	22	22	22
Exhaust Fan VFD 15 HP	51	51	51	51
<b>CONDENSER GUARD OPTIONS</b>				
<b>MODEL</b>	<b>050</b>	<b>051</b>	<b>060</b>	<b>061</b>
Condenser Coil Guard (Wire)	64	64	64	64
Condenser Coil Guard Louvered Sheet Metal)	292	292	292	292
<b>HEAT OPTIONS</b>				
<b>MODEL</b>	<b>050</b>	<b>051</b>	<b>060</b>	<b>061</b>
Electric Heat - 40kW (Max)	410	410	410	410
Electric Heat - 80kW (Max)	430	430	430	430
Electric Heat - 108kW (Max)	450	450	450	450
Electric Heat - 150kW (Max)	470	470	470	470
Electric Heat - 200kW (Max)	490	490	490	490
<b>ECONOMIZER / EXHAUST FAN / RETURN FAN OPTIONS</b>				
<b>MODEL</b>	<b>050</b>	<b>051</b>	<b>060</b>	<b>061</b>
Electric Heat - 250kW (Max)	510	510	510	510
Gas Heat - 375 MBH (Max)	162	162	162	162
Gas Heat - 750 MBH (Max)	324	324	324	324
Gas Heat - 1125 MBH (Max)	486	486	486	486
Hot Water Coil	281	281	281	281
Steam Coil	202	202	202	202





**TABLE 4 - UNIT CENTER OF GRAVITY AND CORNER LOADS**

STANDARD CABINET								
MODEL	50		51		60		61	
COORDINATE	X	Y	X	Y	X	Y	X	Y
BASIC UNIT	189	44	189	44	189	44	190	44
BASIC UNIT W/ ECONO	181	44	181	44	181	44	182	44
BASIC UNIT W/ ECONO and HEATING (Hot Water Heat)	182	44	182	44	182	44	182	44
BASIC UNIT W/ ECONO and HEATING (hot Water Heat) and POWER EXHAUST (10HP motor, modulating damper, no VFD)	171	44	171	44	172	44	172	44
MODEL	50				51			
COORDINATE	A	B	C	D	A	B	C	D
BASIC UNIT	2011	1816	2288	2534	2011	1816	2288	2534
BASIC UNIT W/ ECONO	2236	2031	2318	2553	2236	2031	2318	2553
BASIC UNIT W/ ECONO and HEATING (Hot Water Heat)	2281	2092	2413	2632	2281	2092	2413	2632
BASIC UNIT W/ ECONO and HEATING (hot Water Heat) and POWER EXHAUST (10HP motor, modulating damper, no VFD)	2607	2390	2431	2652	2607	2390	2431	2652
MODEL	60				61			
COORDINATE	A	B	C	D	A	B	C	D
BASIC UNIT	2077	1868	2366	2630	2076	1873	2376	2634
BASIC UNIT W/ ECONO	2302	2082	2395	2649	2301	2087	2406	2653
BASIC UNIT W/ ECONO and HEATING (Hot Water Heat)	2347	2143	2491	2728	2346	2148	2502	2732
BASIC UNIT W/ ECONO and HEATING (hot Water Heat) and POWER EXHAUST (10HP motor, modulating damper, no VFD)	2673	2441	2509	2748	2672	2446	2519	2752



**TABLE 4 - UNIT CENTER OF GRAVITY AND CORNER LOADS (CONT'D)**

EXTENDED CABINET								
MODEL	50		51		60		61	
COORDINATE	X	Y	X	Y	X	Y	X	Y
BASIC UNIT	212	44	212	44	212	44	213	44
BASIC UNIT W/ ECONO	203	44	203	44	204	44	204	44
BASIC UNIT W/ ECONO and HEATING (Hot Water Heat)	204	44	204	44	204	44	205	44
BASIC UNIT W/ ECONO and HEATING (hot Water Heat) and POWER EXHAUST (10HP motor, modulating damper, no VFD)	192	44	192	44	193	44	194	44
MODEL	50				51			
COORDINATE	A	B	C	D	A	B	C	D
BASIC UNIT	2241	2041	2483	2727	2241	2041	2483	2727
BASIC UNIT W/ ECONO	2469	2258	2510	2744	2469	2258	2510	2744
BASIC UNIT W/ ECONO and HEATING (Hot Water Heat)	2522	2327	2598	2815	2522	2327	2598	2815
BASIC UNIT W/ ECONO and HEATING (hot Water Heat) and POWER EXHAUST (10HP motor, modulating damper, no VFD)	2850	2628	2612	2833	2850	2628	2612	2833
MODEL	60				61			
COORDINATE	A	B	C	D	A	B	C	D
BASIC UNIT	2307	2092	2561	2824	2306	2097	2572	2828
BASIC UNIT W/ ECONO	2535	2310	2587	2839	2534	2315	2598	2844
BASIC UNIT W/ ECONO and HEATING (Hot Water Heat)	2588	2378	2675	2911	2587	2383	2686	2915
BASIC UNIT W/ ECONO and HEATING (hot Water Heat) and POWER EXHAUST (10HP motor, modulating damper, no VFD)	2916	2679	2690	2929	2915	2684	2701	2933

**TABLE 5 - UNIT CORNER WEIGHTS - 050-061 MODELS**

<b>STANDARD CABINET</b>								
	<b>50</b>				<b>51</b>			
	<b>A</b>	<b>B</b>	<b>C</b>	<b>D</b>	<b>A</b>	<b>B</b>	<b>C</b>	<b>D</b>
BASIC UNIT	2011	1816	2288	2534	2011	1816	2288	2534
BASIC UNIT W/ ECONO	2236	2031	2318	2553	2236	2031	2318	2553
BASIC UNIT W/ ECONO and HEATING (Hot Water Heat)	2281	2092	2413	2632	2281	2092	2413	2632
BASIC UNIT W/ ECONO and HEATING (hot Water Heat) and POWER EXHAUST (10HP motor, modulating damper, no VFD)	2607	2390	2431	2652	2607	2390	2431	2652
	<b>60</b>				<b>61</b>			
	<b>A</b>	<b>B</b>	<b>C</b>	<b>D</b>	<b>A</b>	<b>B</b>	<b>C</b>	<b>D</b>
BASIC UNIT	2077	1868	2366	2630	2076	1873	2376	2634
BASIC UNIT W/ ECONO	2302	2082	2395	2649	2301	2087	2406	2653
BASIC UNIT W/ ECONO and HEATING (Hot Water Heat)	2347	2143	2491	2728	2346	2148	2502	2732
BASIC UNIT W/ ECONO and HEATING (hot Water Heat) and POWER EXHAUST (10HP motor, modulating damper, no VFD)	2673	2441	2509	2748	2672	2446	2519	2752
<b>EXTENDED CABINET</b>								
	<b>50</b>				<b>51</b>			
	<b>A</b>	<b>B</b>	<b>C</b>	<b>D</b>	<b>A</b>	<b>B</b>	<b>C</b>	<b>D</b>
BASIC UNIT	2241	2041	2483	2727	2241	2041	2483	2727
BASIC UNIT W/ ECONO	2469	2258	2510	2744	2469	2258	2510	2744
BASIC UNIT W/ ECONO and HEATING (Hot Water Heat)	2522	2327	2598	2815	2522	2327	2598	2815
BASIC UNIT W/ ECONO and HEATING (hot Water Heat) and POWER EXHAUST (10HP motor, modulating damper, no VFD)	2850	2628	2612	2833	2850	2628	2612	2833
	<b>60</b>				<b>61</b>			
	<b>A</b>	<b>B</b>	<b>C</b>	<b>D</b>	<b>A</b>	<b>B</b>	<b>C</b>	<b>D</b>
BASIC UNIT	2307	2092	2561	2824	2306	2097	2572	2828
BASIC UNIT W/ ECONO	2535	2310	2587	2839	2534	2315	2598	2844
BASIC UNIT W/ ECONO and HEATING (Hot Water Heat)	2588	2378	2675	2911	2587	2383	2686	2915
BASIC UNIT W/ ECONO and HEATING (hot Water Heat) and POWER EXHAUST (10HP motor, modulating damper, no VFD)	2916	2679	2690	2929	2915	2684	2701	2933

2

## Unit Placement

### ***Elevated***

Elevated roof curbs or dunnage steel can be used to support the unit in order to raise it to specific heights. When this type of placement is required, be sure to keep unit access in mind. Cat walks or other forms of unit access may be required to one or both sides of the unit, depending on your area of the country and the local codes that are enforced. Please check with local officials to ensure the application conforms to local codes and regulations.

### ***Ground Level Locations***

It is important that the units be installed on a substantial base that will not settle, causing strain on the refrigerant lines and sheet metal and resulting in possible leaks. A one piece concrete slab with footers extended below the frost line is highly recommended. Additionally, the slab should be isolated from the main building foundation to prevent noise and vibration transmission to the building structure.

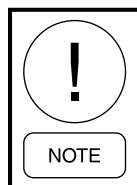
For ground level installations, precautions should be taken to protect the unit from tampering by, or injury to, unauthorized persons. Erecting a fence around the unit is common practice.

## ROOF CURB INSTALLATION

Johnson Controls offers an optional roof curb designed specifically for the Series 100 foot print. This curb comes as an open condenser model and is shipped disassembled and requires field assembly during installation. Refer to the Installation Manual that is shipped with the roof curb for specific instructions. For bottom supply and return openings, the curb has matching connections to ease installation.

The curb should be located according to the location recommendations above, and properly sealed to prevent moisture and air leakage into and out of the duct system. Flexible collars should be used when connecting the duct work to prevent unit noise transmission and vibration into the building. The roof curb drawings contained in the Johnson Controls literature are not intended as construction documents for field fabrication of a roof curb. Johnson Controls will not be responsible for the unit fit up, leak integrity, or sound level with field fabricated roof curbs.

Construction documents for field fabricated roof curbs are available upon request.



***Wood or fiber cant strips, roofing felts, roofing material, caulking and curb-to-roof fasteners are to be field supplied.***

**PHYSICAL DATA**

**TABLE 6 - PHYSICAL DATA – 050-061 MODELS**

UNIT SIZE	050	051	060	061
<b>GENERAL DATA</b>				
Length without hood (inches)	339/386	339/386	339/386	339/386
Width (inches)	92	92	92	92
Height (inches)	82	82	82	82
Unit EER/ IPLV	10.3 / 10.9	10.2 / 10.6	10.1 / 10.4	10.1 / 10.3
Unit EER/ IPV gas heat	10.01	9.91	9.81	9.81
<b>COMPRESSOR DATA (SEE TABLE 7)</b>				
Quantity	4	4	4	4
Type	Scroll	Scroll	Scroll	Scroll
Unit Capacity Steps	4	4	4	4
<b>REFRIGERANT (410A) - EXTENDED CABINET</b>				
SYSTEM 1	49 lbs - 8 oz	49 lbs - 8 oz	58 lbs - 11 oz	58 lbs - 11 oz
SYSTEM 2	49 lbs - 8 oz	49 lbs - 8 oz	58 lbs - 11 oz	58 lbs - 11 oz
<b>SUPPLY FAN</b>				
Quantity	1	1	1	1
Type	FC	FC	FC	FC
Size	28 - 28	28 - 28	28 - 28	28 - 28
Motor Size Range (HP)	10 - 25	10 - 25	10 - 25	10 - 25
Air Flow Range (CFM) cooling Min.	10,000 - 22,500	10,000 - 22,500	12,500 - 24,000	10,000 - 24,000
Static Pressure Range (total)	1.0" - 6.0"	1.0" - 6.0"	1.0" - 6.0"	1.0" - 6.0"
<b>OPTIONAL SUPPLY FAN</b>				
Quantity	1	1	1	1
Type	AF	AF	AF	AF
Size	28	28	28	28
Motor Size Range (HP)	10 - 40	10 - 40	10 - 40	10 - 40
Air Flow Range (CFM) cooling Min.	10,000 - 22,500	10,000 - 22,500	10,000 - 24,000	10,000 - 24,000
Static Pressure Range (total)	1.0" - 8.0"	1.0" - 8.0"	1.0" - 8.0"	1.0" - 8.0"
<b>EXHAUST FAN</b>				
Quantity Fans/Motors	2 / 1	2 / 1	2 / 1	2 / 1
Type	FC	FC	FC	FC
Size	18 - 18	18 - 18	18 - 18	18 - 18
Motor Size Range (HP)	5 - 15	5 - 15	5 - 15	5 - 15
Air Flow Range (CFM)	4,000 - 22,500	4,000 - 22,500	4,000 - 24,000	4,000 - 24,000
Static Pressure Range (total)	0.1" - 1.5"	0.1" - 1.5"	0.1" - 1.5"	0.1" - 1.5"
<b>EVAPORATOR COIL</b>				
Size (square feet)	52	52	52	52
Rows/FPI	3 / 17	3 / 17	4 / 17	4 / 17
<b>CONDENSER COIL</b>				
Size (square feet)	88	88	88	88
Rows/FPI	2 / 17	2 / 17	3 / 17	3 / 17
<b>CONDENSER FANS</b>				
Quantity	4	4	4	4
Type	Prop.	Prop.	Prop.	Prop.
Diameter (inches)	36	36	36	36
Motor HP	2	2	2	2

**TABLE 6 - PHYSICAL DATA – 050-061 MODELS (CONT'D)**

<b>UNIT SIZE</b>	<b>050</b>	<b>051</b>	<b>060</b>	<b>061</b>
<b>FILTERS - 2" THROWAWAY (PRE-FILTER POSITION), MERV 4</b>				
Quantity	4 / 12	4 / 12	4 / 12	4 / 12
Size (length x width) (in.)	12X24 / 24X24	12X24 / 24X24	12X24 / 24X24	12X24 / 24X24
Total Filter Face Area (square feet)	56	61.6	61.6	61.6
<b>FILTERS - 2" CLEANABLE (PRE-FILTER POSITION), MERV 1</b>				
Quantity	4 / 12	4 / 12	4 / 12	4 / 12
Size (length x width) (in.)	12X24 / 24X24	12X24 / 24X24	12X24 / 24X24	12X24 / 24X24
Total Filter Face Area (square feet)	56	63.9	63.9	63.9
<b>FILTERS - 2" PLEATED, 30% EFFICIENT (PRE-FILTER POSITION), MERV 8</b>				
Quantity	4 / 12	4 / 12	4 / 12	4 / 12
Size (length x width) (in.)	12X24 / 24X24	12X24 / 24X24	12X24 / 24X24	12X24 / 24X24
Total Filter Face Area (square feet)	56	63.9	63.9	63.9
<b>FILTERS -12" RIGID 65%, 2" 30% PREFILTER (PRE-FILTER POSITION), MERV 11 AND 8</b>				
Quantity	1 / 4 / 9	1 / 4 / 9	1 / 4 / 9	1 / 4 / 9
Size (length x width) (in.)	16x20/25x16/25x20	16x20/25x16/25x20	16x20/25x16/25x20	16x20/25x16/25x20
Total Filter Face Area (square feet)	43.0	43.0	43.0	43.0
<b>FILTERS -12" RIGID 95%, 2" 30% PREFILTER (PRE-FILTER POSITION), MERV 14 AND 8</b>				
Quantity	1 / 4 / 9	1 / 4 / 9	1 / 4 / 9	1 / 4 / 9
Size (length x width) (in.)	16x20/25x16/25x20	16x20/25x16/25x20	16x20/25x16/25x20	16x20/25x16/25x20
Total Filter Face Area (square feet)	44.6	44.6	44.6	44.6
<b>FILTERS - 2" CARBON (PRE-FILTER POSITION), MERV 8</b>				
Quantity	4 / 12	4 / 12	4 / 12	4 / 12
Size (length x width) (in.)	12X24 / 24X24	12X24 / 24X24	12X24 / 24X24	12X24 / 24X24
Total Filter Face Area (square feet)	56	63.9	63.9	63.9
<b>FILTERS - 12" RIGID 95% IN POST-FILTER POSITION, MERV 14</b>				
Quantity	3 / 9	3 / 9	3 / 9	3 / 9
Size (length x width) (in.)	16x20/25x16/25x20	16x20/25x16/25x20	16x20/25x16/25x20	16x20/25x16/25x20
Total Filter Face Area (square feet)	39.6	39.6	39.6	39.6

**TABLE 6 - PHYSICAL DATA – 050-061 MODELS (CONT'D)**

UNIT SIZE		050	051	060	061
<b>GAS FURNACES</b>					
<b>Staged Furnace Sizes (input/output/steps)</b>		375 mbh / 300 mbh / 2 steps			
		750 mbh / 600 mbh / 4 steps			
		1125 mbh / 900 mbh / 6 steps			
<b>Inlet Gas Pressure Range</b>	Natural	4.5–10.5 "W.C.	4.5–10.5 "W.C.	4.5–10.5 "W.C.	4.5–10.5 "W.C.
	Propane	11.0–13.0 "W.C.	11.0–13.0 "W.C.	11.0–13.0 "W.C.	11.0–13.0 "W.C.
<b>Airflow Range (MIN HEATING)</b>	375 MBH	7,500	7,500	11,500	11,500
	750 MBH	14,000	14,000	14,000	14,000
	1125 MBH	21,000	21,000	21,000	21,000
<b>Modulating Furnace Sizes (Input/Output/Turndown)</b>		375 mbh / 300 mbh / 8:1 TURNDOWN			
		750 mbh / 600 mbh / 16:1 TURNDOWN			
		1125 mbh / 900 mbh / 24:1 TURNDOWN			
<b>Inlet Gas Pressure Range</b>	Natural	4.5–10.5 "W.C.	4.5–10.5 "W.C.	4.5–10.5 "W.C.	4.5–10.5 "W.C.
	Propane	11.0–13.0 "W.C.	11.0–13.0 "W.C.	11.0–13.0 "W.C.	11.0–13.0 "W.C.
<b>Airflow Range (MIN HEATING)</b>	375 MBH	7,500	7,500	11,500	11,500
	750 MBH	14,000	14,000	14,000	14,000
	1125 MBH	21,000	21,000	21,000	21,000
<b>Minimum OA Temp for Mech. Cig.</b>		40.0 °F	40.0 °F	40.0 °F	40.0 °F
<b>Low Ambient Option Min. OA Temp</b>		0.0 °F	0.0 °F	0.0 °F	0.0 °F

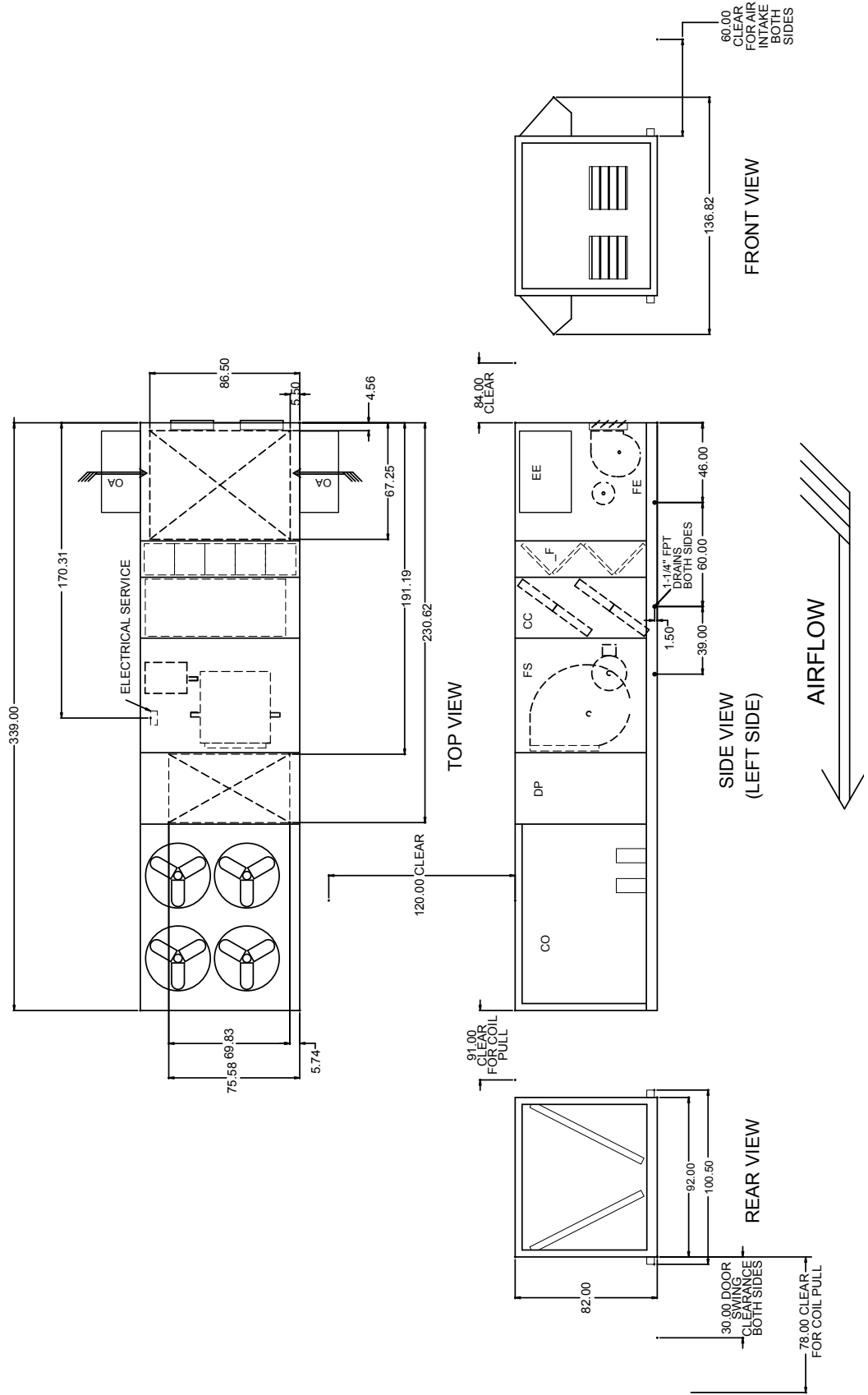
**TABLE 7 - PHYSICAL DATA - COMPRESSORS**

		COMPRESSORS UTILIZED				COMPRESSOR NOMINAL HP				CAPACITY %			
		SYSTEM 1		SYSTEM 2		SYSTEM 1		SYSTEM 2					
		1A	1B	2A	2B	1A	1B	2A	2B	1A	1B	2A	2B
<b>MODEL</b>	<b>50</b>	ZP120	ZP137	ZP120	ZP137	10	12	10	12	24	48	74	100
	<b>51</b>	ZP137	ZP137	ZP137	ZP137	12	12	12	12	25	50	75	100
	<b>60</b>	ZP137	ZP182	ZP137	ZP182	12	15	12	15	21.5	43.1	72.1	100
	<b>61</b>	ZP137	ZP182	ZP154	ZP182	12	15	13	15	12.1	44.2	72.1	100

**SECTION DESCRIPTIONS:**

- EE = Economizer
- FE = Fan Exhaust
- \_F = Filter Segments
- CC = Cooling Coils
- FS = Supply Fan
- DP = Discharge Plenum
- CO = Condenser Section

- NOTES:**
1. 10' clearance minimal over the top of the condensing unit.
  2. Only one adjacent wall can exceed unit height.
  3. 12' clearance required to adjacent units.
  4. 8" service access recommended on one side.
  5. Economizer and exhaust hoods, where applicable are folded inside unit for shipment.



**FIGURE 6 - LOCATION AND DIMENSION DRAWING / 050-061 MODELS, BOTTOM SUPPLY / BOTTOM RETURN, STANDARD CABINET**

LD08295B

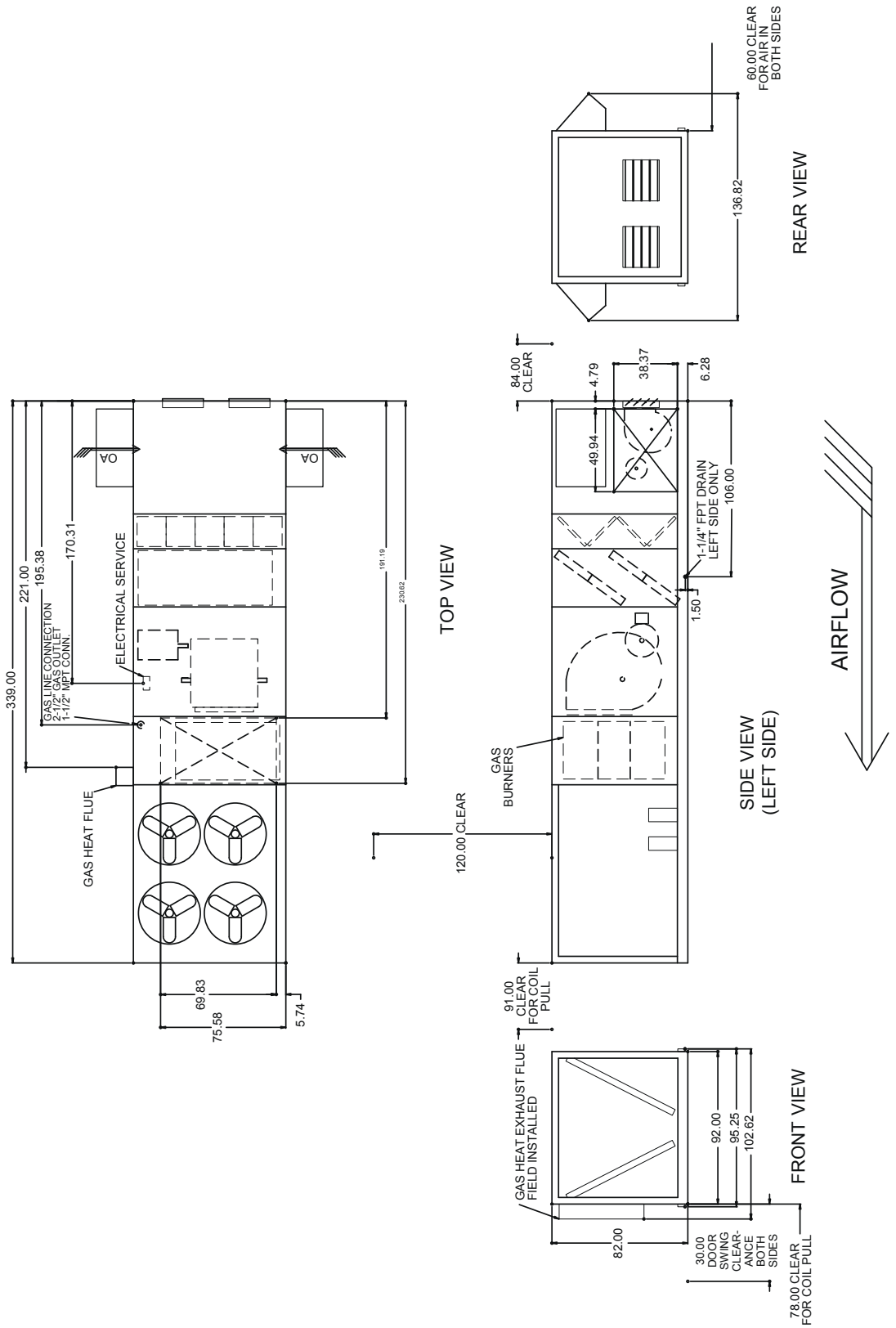


**SECTION DESCRIPTIONS:**

- EE = Economizer
- FE = Fan Exhaust
- \_F = Filter Segments
- CC = Cooling Coils
- FS = Supply Fan
- DP = Discharge Plenum
- CO = Condenser Section

**NOTES:**

1. 10' clearance minimal over the top of the condensing unit.
2. Only one adjacent wall can exceed unit height.
3. 12' clearance required to adjacent units.
4. 8' service access recommended on one side.
5. Economizer and exhaust hoods, where applicable are folded inside unit for shipment.



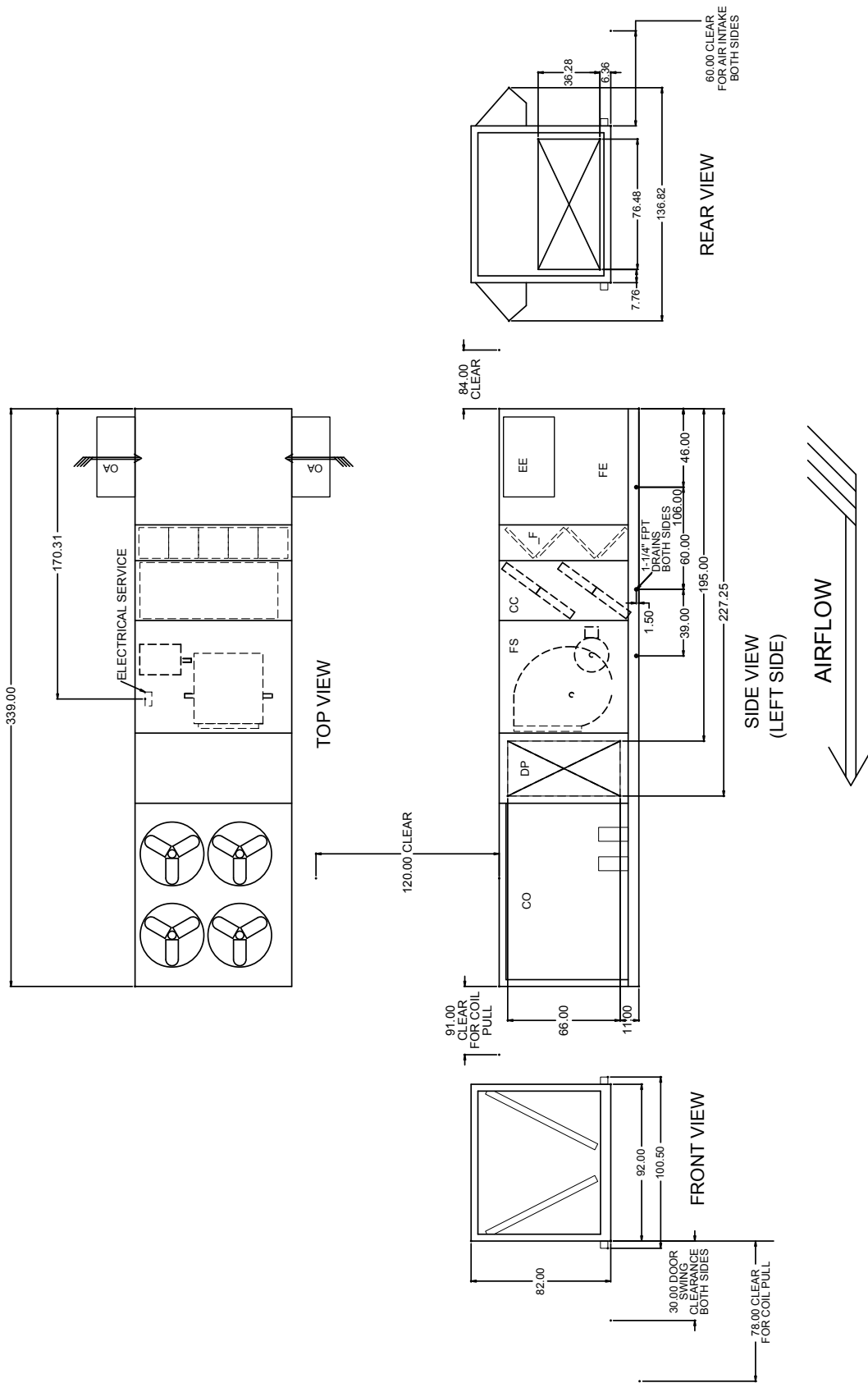
**FIGURE 7 - LOCATION AND DIMENSION DRAWING / 050-061 MODELS, BOTTOM SUPPLY / SIDE RETURN, STANDARD CABINET**

**NOTES:**

1. 10' clearance minimal over the top of the condensing unit.
2. Only one adjacent wall can exceed unit height.
3. 12' clearance required to adjacent units.
4. 8' service access recommended on one side.
5. Economizer and exhaust hoods, where applicable are folded inside unit for shipment.

**SECTION DESCRIPTIONS:**

- EE = Economizer
- FE = Fan Exhaust
- \_F = Filter Segments
- CC = Cooling Coils
- FS = Supply Fan
- DP = Discharge Plenum
- CO = Condenser Section

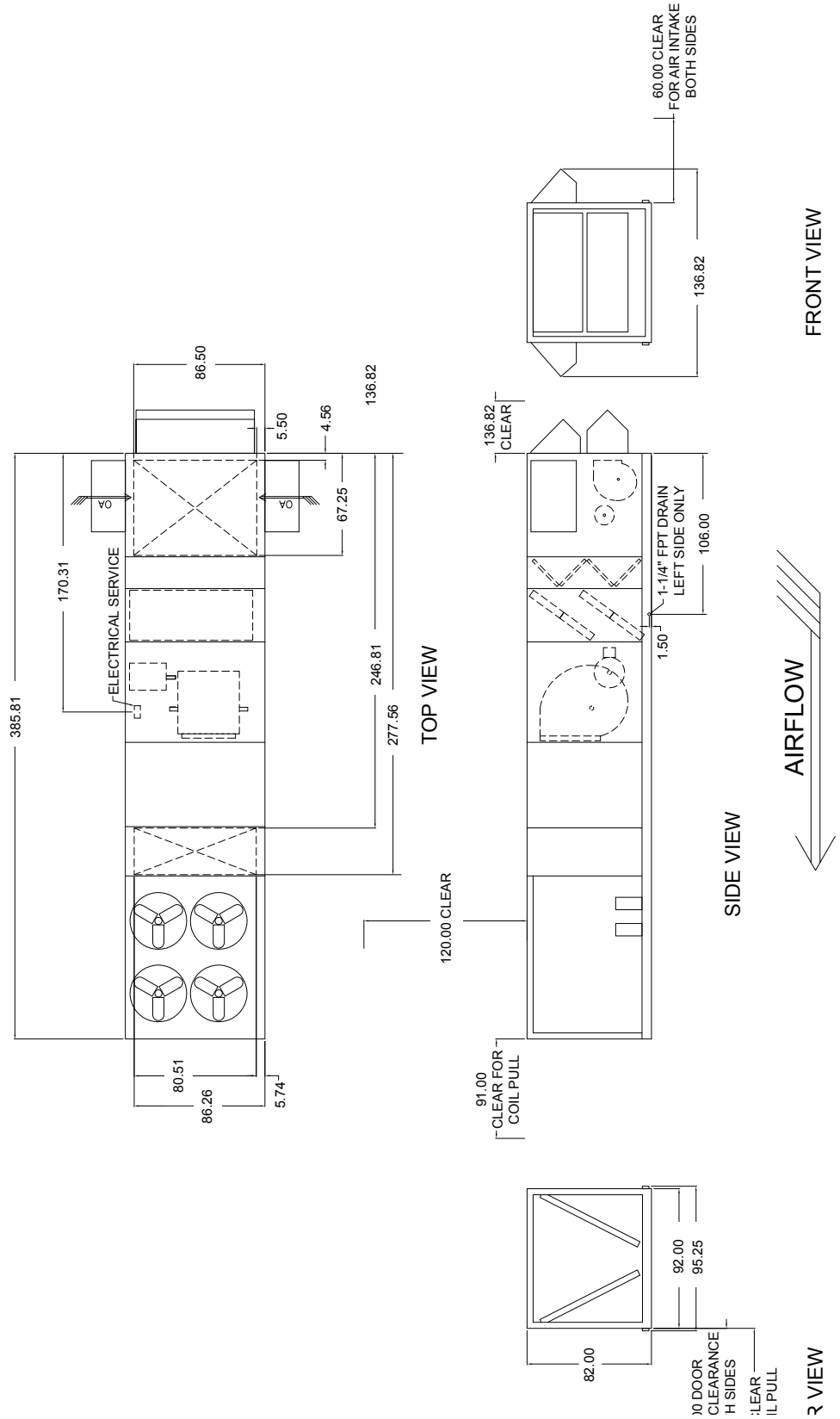


**FIGURE 8 - LOCATION AND DIMENSION DRAWING / 050-061 MODELS, SIDE SUPPLY / REAR RETURN, STANDARD CABINET**

LD08296A

**NOTES:**

1. 10' clearance minimal over the top of the condensing unit.
2. Only one adjacent wall can exceed unit height.
3. 12' clearance required to adjacent units.
4. 8' service access recommended on one side.
5. Economizer and exhaust hoods, where applicable are folded inside unit for shipment.

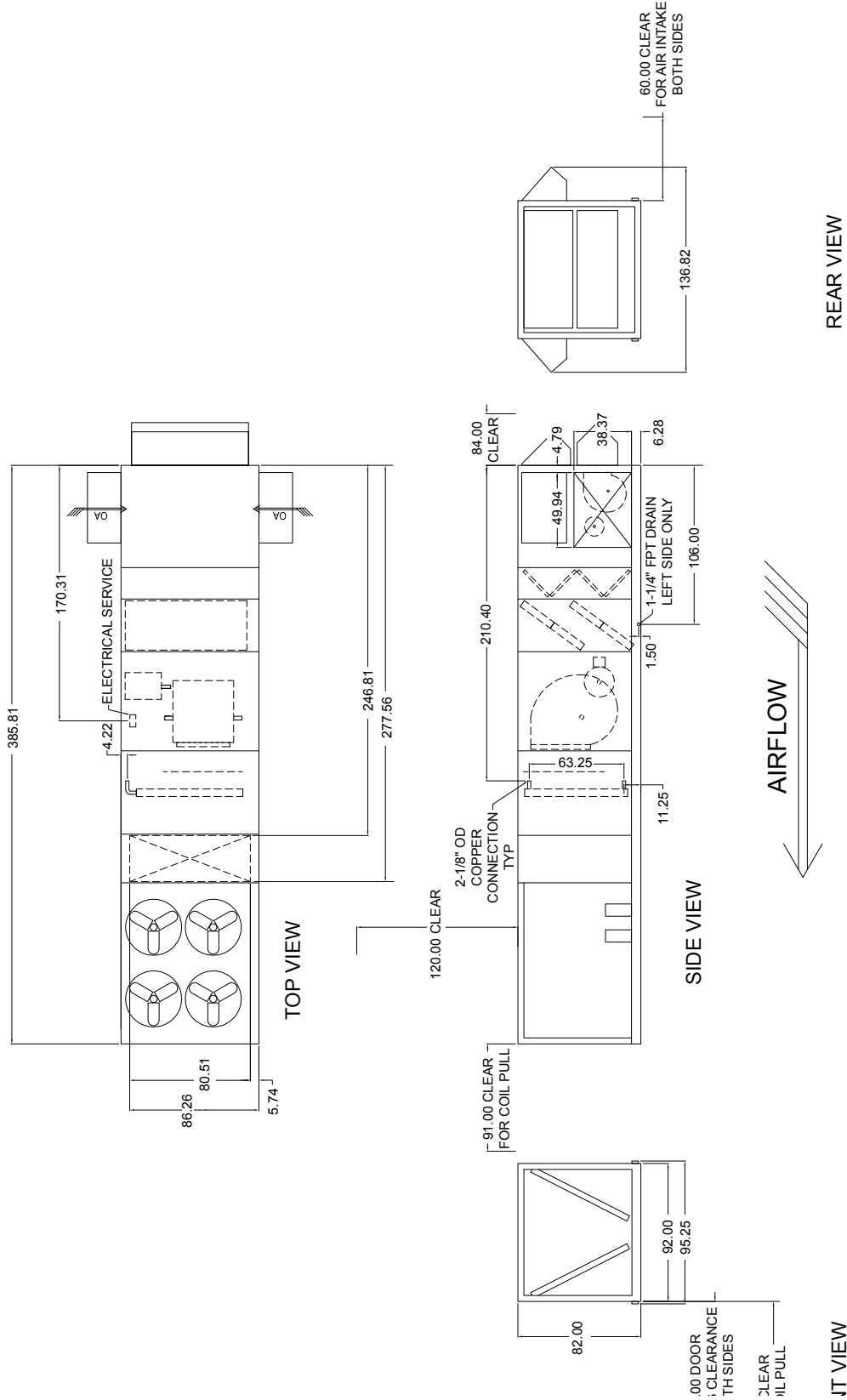


**FIGURE 9 - LOCATION AND DIMENSION DRAWING, / 050-061 MODELS, BOTTOM SUPPLY / BOTTOM RETURN, EXTENDED CABINET**

LD14761

**NOTES:**

1. 10' clearance minimal over the top of the condensing unit.
2. Only one adjacent wall can exceed unit height.
3. 12' clearance required to adjacent units.
4. 8' service access recommended on one side.
5. Economizer and exhaust hoods, where applicable are folded inside unit for shipment.

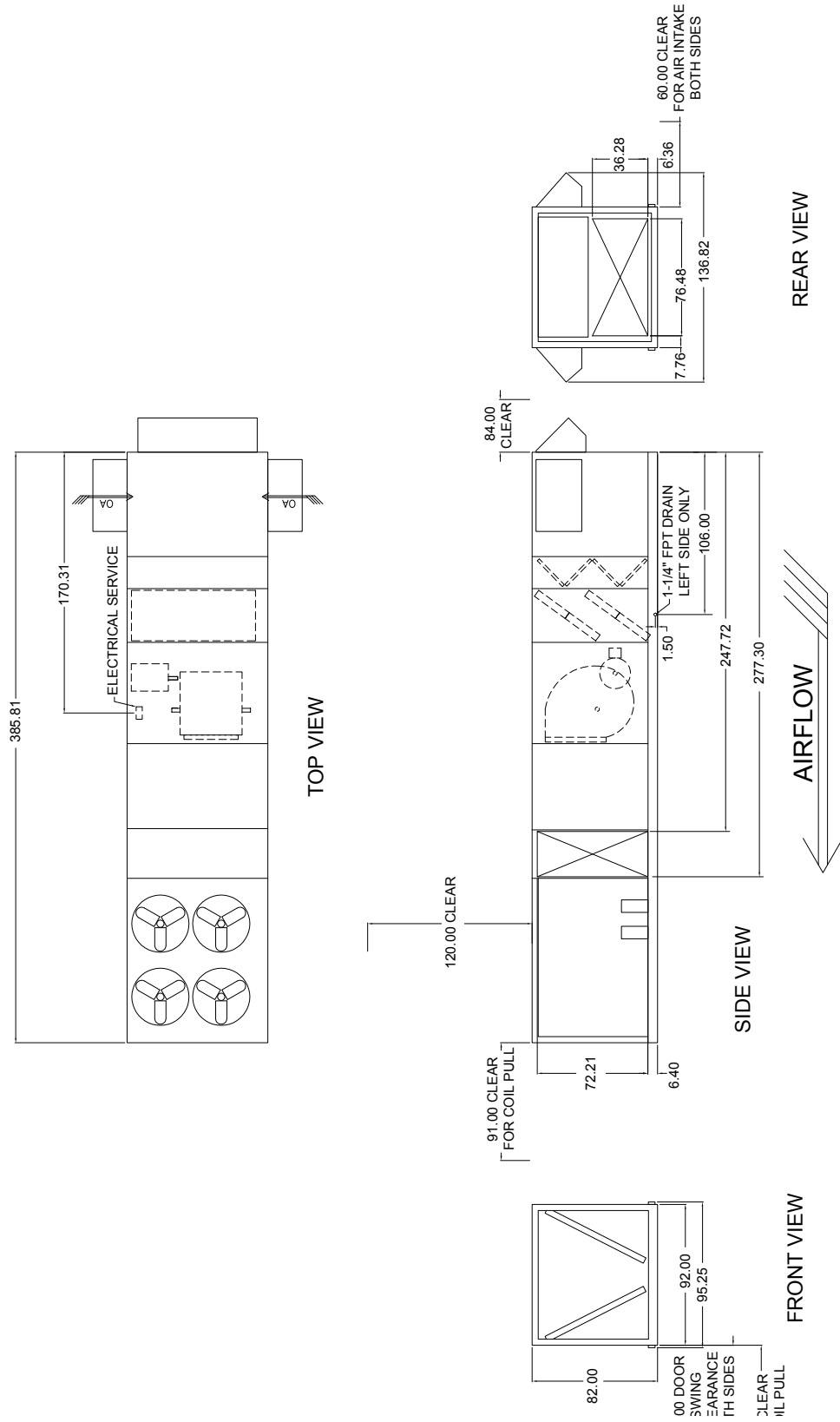


LD14762

**FIGURE 10 - LOCATION AND DIMENSION DRAWING / 050-061 MODELS, BOTTOM SUPPLY / SIDE RETURN, EXTENDED CABINET**

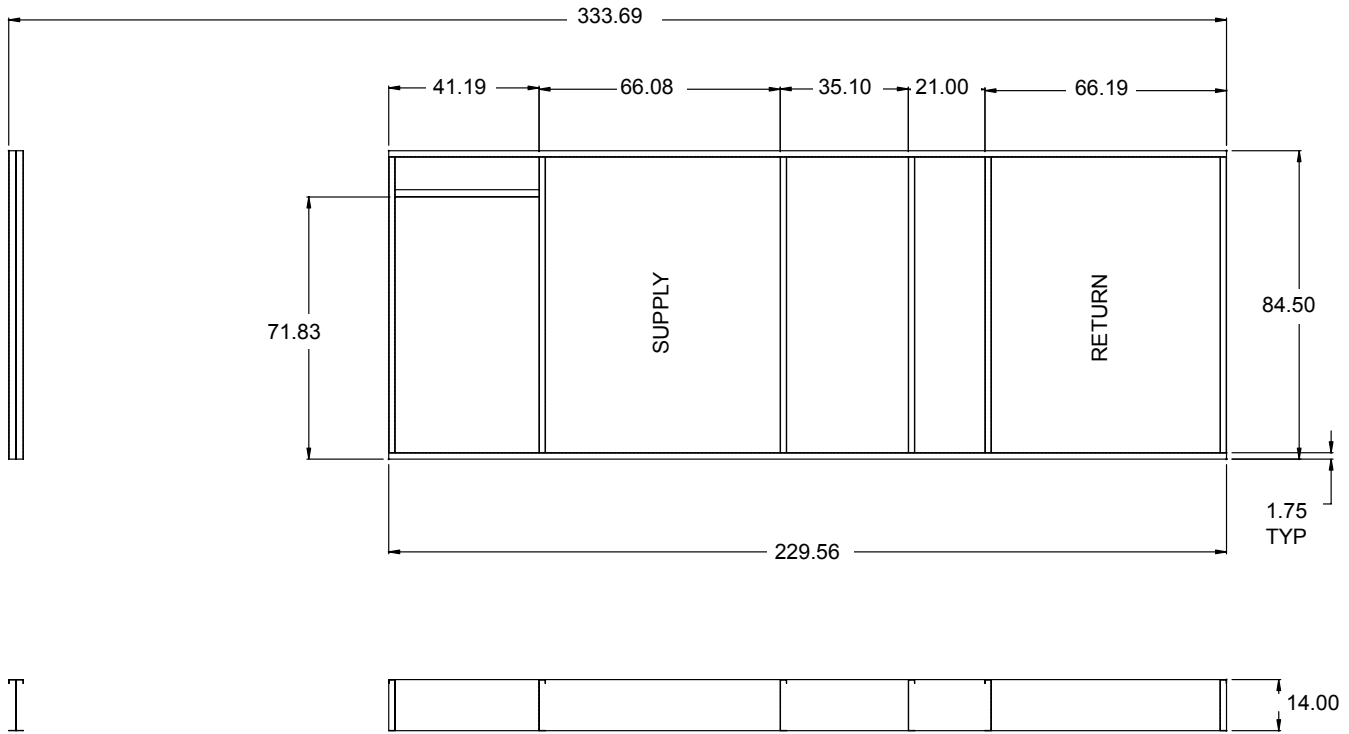
**NOTES:**

1. 10' clearance minimal over the top of the condensing unit.
2. Only one adjacent wall can exceed unit height.
3. 12' clearance required to adjacent units.
4. 8' service access recommended on one side.
5. Economizer and exhaust hoods, where applicable are folded inside unit for shipment.



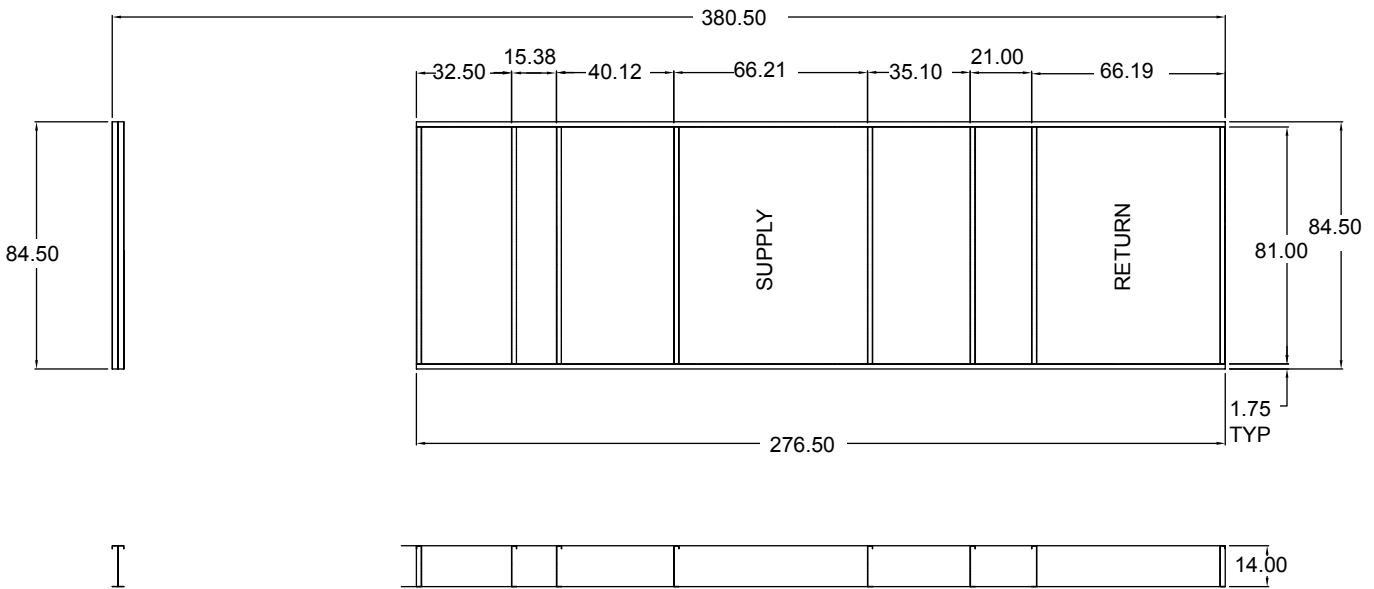
**FIGURE 11 - LOCATION AND DIMENSION DRAWING / 050-061 MODELS, SIDE SUPPLY / REAR RETURN, EXTENDED CABINET**

LD14763



STANDARD CABINET

LD08297



EXTENDED CABINET

LD14765

**NOTES:**

1. Unit must be installed square and level.
2. Curb configuration for "bottom" return and "bottom" supply.
3. These drawings are not intended as construction documents for the field fabricated roof curbs. Johnson Controls will not be responsible for the unit fit up, leak integrity, or sound level for installation using field fabricated roof curbs.
4. The Series 100 unit does not have a base pan under the condensing section of the unit. Field fabricated roof curbs must have a cap on the top of the condensing section of the curb to prevent moisture from entering the space. The cap design must be sloped away from the supply duct opening to the end of the unit for the drainage of the moisture off of the top of the cap.

**FIGURE 12 - CURB LAYOUT DRAWING / 050-061 MODELS, STANDARD AND EXTENDED CABINET**

## ELECTRICAL DATA

### Electrical Service Sizing

In order to use the electrical service required for the cooling-only Packaged Rooftop Unit, use the appropriate calculations listed below from U.L. 1995. Based on the configuration of the rooftop, the calculations will yield different MCA (minimum circuit ampacity), and MOP (maximum overcurrent protection).

Using the following load definitions and calculations, determine the correct electrical sizing for your unit. All concurrent load conditions must be considered in the calculations, and you must use the highest value for any combination of loads.

#### Load Definitions

- **LOAD1** is the current of the largest motor – compressor or fan motor.
- **LOAD2** is the sum of the remaining motor currents that may run concurrently with LOAD1.

- **LOAD3** is the current of the electric heaters – zero for cooling-only units.
- **LOAD4** is the sum of any remaining currents greater than or equal to 1.0 amp.

Use the following calculations to determine MCA and MOP for units supplied with a single-point power connection:

$$MCA = (1.25 \times \text{LOAD1}) + \text{LOAD2} + \text{LOAD3} + \text{LOAD4}$$

$$MOP = (2.25 \times \text{LOAD1}) + \text{LOAD2} + \text{LOAD3} + \text{LOAD4}$$

If the MOP does not equal a standard current rating of an overcurrent protective device, then the marked maximum rating is to be the next lower standard rating. However, if the device selected for MOP is less than the MCA, then select the lowest standard maximum fuse size greater than or equal to the MCA.

**TABLE 8 - COMPRESSOR DATA - R-410A**

MODEL	COMPRESSOR	MODEL	NOMINAL VOLTAGE					
			208-230/3/60		460/3/60		575/3/60	
			RLA*	LRA	RLA*	LRA	RLA*	LRA
050	1A	ZP120	33.3	239	17.9	125	12.8	80
	1B	ZP137	48.0	245	18.6	125	14.7	100
	2A	ZP120	33.3	239	17.9	125	12.8	80
	2B	ZP137	48.0	245	18.6	125	14.7	100
051	1A	ZP137	48.0	245	18.6	125	14.7	100
	1B	ZP137	48.0	245	18.6	125	14.7	100
	2A	ZP137	48.0	245	18.6	125	14.7	100
	2B	ZP137	48.0	245	18.6	125	14.7	100
060	1A	ZP137	48.0	245	18.6	125	14.7	100
	1B	ZP182	55.7	340	26.9	172	23.7	132
	2A	ZP137	48.0	245	18.6	125	14.7	100
	2B	ZP182	55.7	340	26.9	172	23.7	132
061	1A	ZP137	48.0	245	18.6	125	14.7	100
	1B	ZP182	55.7	340	25.0	172	23.7	132
	2A	ZP154	51.3	300	22.4	150	19.8	109
	2B	ZP182	55.7	340	25.0	172	23.7	132

**TABLE 9 - POWER SUPPLY VOLTAGE LIMITS**

POWER SUPPLY	MINIMUM VOLTAGE	MAXIMUM VOLTAGE
208/230V/3PH/60HZ	187	253
460V/3PH/60HZ	414	506
575V/3PH/60HZ	518	632

**TABLE 10 - CONDENSER FAN MOTOR RLA - STANDARD FAN**

RLA EACH MOTOR		208V/3PH/60HZ	230V/3PH/60HZ	460V/3PH/60HZ	575V/3PH/60HZ
		7.3	6.2	3.1	2.5
MODEL	QUANTITY OF FANS	208V/3PH/60HZ	230V/3PH/60HZ	460V/3PH/60HZ	575V/3PH/60HZ
50-60 Tons	4	29.2	24.8	12.4	10.0

**TABLE 11 - CONDENSER FAN MOTOR RLA - LOW SOUND FAN (FUTURE OPTION)**

RLA EACH MOTOR		208V/3PH/60HZ	230V/3PH/60HZ	460V/3PH/60HZ	575V/3PH/60HZ
		7.3	6.2	3.1	2.5
MODEL	QUANTITY OF FANS	208V/3PH/60HZ	230V/3PH/60HZ	460V/3PH/60HZ	575V/3PH/60HZ
50-60 Tons	4	32.4	27.6	13.6	12.0

**TABLE 12 - SUPPLY AND EXHAUST FAN MOTOR DATA - ODP**

MOTOR HP	HIGH EFFICIENCY				
	NOMINAL VOLTAGE				
	208/3/60	230/3/60	380/3/60	460/3/60	575/3/60
	FLA	FLA	FLA	FLA	FLA
5	14.0	13.8	8.3	6.9	5.3
7.5	21.7	20.0	13.3	10.0	8.2
10	28.2	26.0	17.5	13.0	11.0
15	41.0	38.0	24.5	19.0	16.2
20	53.0	48.0	32.0	24.0	19.8
25	66.0	62.0	39.0	31.0	23.8
30	84.0	72.0	46.0	36.0	29.0
40	106.0	98.0	59.0	49.0	38.8

MOTOR HP	PREMIUM EFFICIENCY				
	NOMINAL VOLTAGE				
	208/3/60	230/3/60	460/3/60	575/3/60	
	FLA	FLA	FLA	FLA	FLA
5	13.8	13.2	6.6	5.2	
7.5	20.0	19.4	9.7	7.4	
10	26.0	25.0	12.5	10.3	
15	37.4	35.4	17.7	14.1	
20	49.4	47.0	23.5	18.9	
25	63.3	60.0	30.0	24.2	
30	74.1	70.0	35.0	28.0	
40	97.5	92.0	46.0	37.4	

**TABLE 13 - SUPPLY AND EXHAUST FAN MOTOR DATA - TEFC**

MOTOR HP	HIGH EFFICIENCY				
	NOMINAL VOLTAGE				
	208/3/60	230/3/60	380/3/60	460/3/60	575/3/60
	FLA	FLA	FLA	FLA	FLA
5	15.4	14.2	8.1	7.1	5.4
7.5	21.2	19.6	12.0	9.8	8.2
10	27.5	25.6	16.8	12.8	11.4
15	40.0	37.0	23.8	18.5	15.3
20	54.0	50.0	30.0	25.0	19.1
25	64.0	60.0	39.0	30.0	25.0
30	78.0	72.0	46.0	36.0	29.6
40	101.0	94.0	57.0	47.0	38.0

MOTOR HP	PREMIUM EFFICIENCY				
	NOMINAL VOLTAGE				
	208/3/60	230/3/60	460/3/60	575/3/60	
	FLA	FLA	FLA	FLA	FLA
5	13.6	13.0	6.5	5.2	
7.5	21.0	18.8	9.4	8.0	
10	26.0	25.0	12.5	10.0	
15	38.9	37.0	18.5	14.8	
20	51.0	48.0	24.0	19.0	
25	63.3	60.0	30.0	23.9	
30	77.0	72.0	36.0	29.0	
40	99.0	92.0	46.0	36.8	

**TABLE 14 - MISCELLANEOUS ELECTRICAL DATA**

DESCRIPTION	NOMINAL VOLTAGE			
	208 / 230V	460V	575V	380V-60
	AMPS	AMPS	AMPS	AMPS
CONTRL TRANSFORMER 500 VA	2.4	1.1	0.9	2
CONVENIENCE OUTLET	9.6	4.4	3.5	N/A
GAS HEAT	9.6	4.4	3.5	5.3



**TABLE 15 - ELECTRIC HEAT**

KW	NOMINAL VOLTAGE			
	208/3/60 AMPS	230/3/60 AMPS	460/3/60 AMPS	575/3/60 AMPS
40	96	96	48	40
80	193	193	96	80
108	260	260	130	109
150	—	—	181	151

**TABLE 16 - AIRFLOW AND ENTERING AIR/AMBIENT LIMITATIONS**

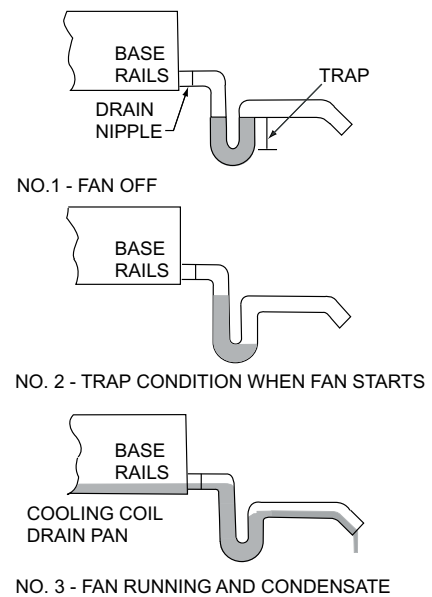
LIMITATIONS	MODEL SIZE			
	50	51	60	61
Minimum Airflow at Standard Design Conditions. CFM* (min to max)	10000 - 22500	10000 - 22500	12500- 24000	12500 - 24000
Entering Wet Bulb Temp (°F) (min/max)	57/75	57/75	57/75	57/75
Entering Dry Bulb Temp (°F) (min/max)	68/90	68/90	68/90	68/90
Ambient Temp (°F) without Low Amb option	50/120	50/120	50/120	50/120
Ambient Temp (°F) with Low Amb option	0/120	0/120	0/120	0/120

\* Cooling-Only Units

**FILTERS**

Two-inch “throwaway” filters are standard and factory installed in a filter rack located prior to the evaporator coil. Any optional pre-filters ordered with the unit will be shipped inside the unit, but must be field installed. The unit can also be ordered with an extended cabinet and 95% efficient post-filters. These post-filters are installed at the factory.

Pre-filters must always be installed ahead of the evaporator coil. Post and pre-filters must be kept clean and replaced with the same size and type as shipped with the unit. Dirty filters will reduce the capacity of the unit and may result in frosted coils and safety shut-downs. Required filter sizes and quantities are shown in *Table 6 on page 29*. The unit should never be operated for any length of time without the proper filters installed in the unit.



LD13269

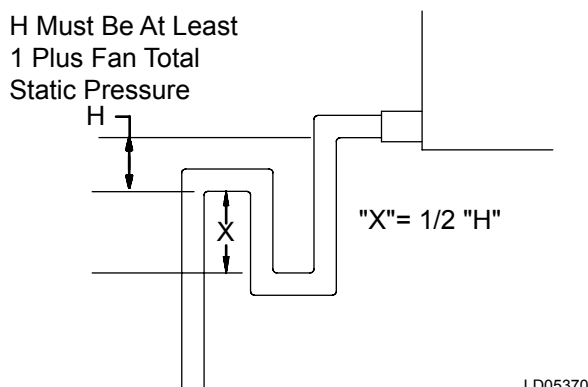
**FIGURE 13 - DRAIN TRAP SHOWING WATER LOCATION DURING DRAW THROUGH OPERATION STAGES**

## CONDENSATE DRAIN

### Condensate Drain Piping

The Series 100 cooling coils are located in the units so that the supply air is drawn through them. This results in the condensate being subjected to negative (-) static pressure. Unless some means of pressure equalization is provided in the condensate drain, the air rushing back through the drainpipe will cause the condensate to build up in the base rails. As the unit continues to operate, the accumulated water will be carried with the air stream, overflowing the base rails causing possible water leaks into the supply duct and/or causing water damage in the building. A trap must be installed to prevent this condensate water build-up (see *Figure 13 on page 41* and *Figure 14 on page 42*).

Under high latent load conditions condensate may form in the base and side rails of the unit. The unit is designed to contain this moisture and prevent it from leaking into the conditioned space. In order to dispose of this condensate, two condensate drain connections are located on the side rails on each side of the unit and in the base rail on the return end of the unit. There are six condensate drains on the unit. Since these connections are also under negative pressure, they must be trapped using the same design criteria as the main drain pan.

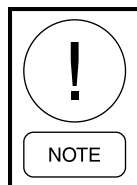


**FIGURE 14 - TRAP DETAIL FOR DRAW THROUGH APPLICATION**

### Condensate Drain Trap

For “Draw-through” applications, install a trapped condensate drain line at unit drain connection (see *Figure 15 on page 45*) according to all governing codes. “H” dimension must be at least 1 inch greater than design Total Static Pressure (TSP) of fan.

The trap and drain lines should be protected from freezing. Plumbing must conform to local codes. Use a sealing compound on male pipe threads. Install condensate drain lines from the 1-1/4 inch NPT female connections on the unit to an open drain.



***The unit must be properly trapped and charged with water before the units are started.***

### AIR HOODS FOR ECONOMIZER

There are three economizers outside air intake hoods provided with the unit. The front and rear hoods are made operational per the following instructions:

- Remove the screws holding the economizer hood shipping covers in place. Discard covers.
- Apply a bead of RTV sealer along the edge of both hoods and each pivot joint to prevent water leakage.
- Rotate the hoods out (each hood is hinged). Secure the hoods with screws along the top and sides.
- Seal any unused screw holes with RTV or by replacing the screw.

### AIR HOODS FOR FIXED OUTSIDE AIR (UNITS WITHOUT ECONOMIZER)

The hoods must be installed per the above instructions. The dampers may be adjusted by loosening the thumb screw, turning the lever to the desired position, and re-tightening the thumb screw.

### AIR HOODS FOR EXHAUST AIR

No hoods are required for the exhaust air outlet.

### FIELD WIRING

*Figure 15 on page 45* and *Figure 16 on page 46* show the field control wiring to CTB1. All field control wiring is field supplied and installed.

### Thermostat

A thermostat (2 stage cool or 2 stage heat) can be used on CV units. On CV units the thermostat is the primary means of control for the unit. The thermostat should be mounted on an inside wall approximately 56" above the floor where it will not be subject to drafts, sun exposure or heat from electrical fixtures or appliances.

## Space Sensor

The space sensor (if used) can be used on either CV or VAV units. The space sensor can be used for unit control in lieu of a thermostat on CV units. For SZ-VAV units, only a space sensor can be used. This can be hardwired or a communicated signal. Even if a thermostat is wired to the rooftop unit, the space sensor will supply space air temperature values if connected. When mounting a space sensor, it should be located on an inside wall approximately 56" above the floor where it will not be subject to drafts, sun exposure or heat from electrical fixtures or appliances. **Shielded Wire must be used that is grounded at control panel only.** The Unit Controller does not accommodate setpoint adjustment at the space sensor.

## CO<sub>2</sub> Sensor

The optional CO<sub>2</sub> sensor is used for Demand Ventilation. When ordered a CO<sub>2</sub> sensor is installed in the outdoor and return air stream.

## Occupied/Unoccupied Input

A contact-closure input is provided for hard-wiring an external device such as a central time clock, a thermostat with scheduling, or a manual switch.

Contact Closure equals Occupied

Contacts Open equals Unoccupied

Note that 24 volts (24 VAC), Terminal 1 of the Terminal Block CTB1, must be used as the 24VAC source for switching the contact to the Unit Controller Occupied/Unoccupied input. Use of any power source external to the controller will result in damage to the Unit Controller.

## Shutdown Input

A contact-closure input is provided for emergency shutdown of the unit. When this circuit is open, the unit shuts down with supply fan, exhaust fan turned OFF, and outside air dampers are closed. This state is maintained until the input is activated (contacts closed).

Contact Closed equals Normal Operation

Contacts Open equals Shutdown

Note that a jumper is installed at the factory between terminals 3 (24 VAC) and Terminal 4 (SD) of the low voltage Terminal Block CTB1. When a field shutdown input is used, the jumper must be removed and the ex-

ternal dry contact connected between Terminal 3 and 4. The connection of an external power supply to these terminals will result in damage to the Unit Controller.

## Smoke Purge Input

There are three field connection points for Smoke Purge operation, "Smoke Purge 1," "Smoke Purge 2," and "Smoke Purge 3." When a field supplied dry contact is closed between Terminal 3 (24 VAC) and Terminal 6 (SMK1) the unit will initiate whatever smoke purge sequence has been programmed into the Unit Controller for Smoke Purge Sequence 1. When a field supplied dry contact is closed between Terminal 3 (24 VAC) and Terminal 7 (SMK2) the unit will initiate whatever smoke purge sequence has been programmed into the Unit Controller for Smoke Purge Sequence 2. When a field supplied dry contact is closed between Terminal 3 (24 VAC) and Terminal 8 (SMK3) the unit will initiate whatever smoke purge sequence has been programmed into the Unit Controller for Smoke Purge Sequence 3. Refer to *Smoke Purge on page 120* for additional programming information. The Smoke Purge operating state will be maintained until the contact is opened.



***No external power source may be used when field wiring any of the above inputs. The 24VAC source on Terminal 3 (24 VAC) of the Terminal Block CTB1 must be used as the power source when field wiring these inputs, as shown in Figure 14. Failure to do so will result in improper unit operation and damage to the Unit Controller.***

## VAV Heat Relay Output

This is a field wired *OUTPUT* that is used to command the VAV boxes to full open during morning warm up operation. This 24VAC signal should have a maximum current draw not to exceed 20VA. If the VA requirement of the VAV boxes approaches 20VA, isolation relays should be field supplied and installed to avoid overloading the unit power supply.

Note that this signal is used to drive the VAV boxes open in morning warm up operations. Failure to drive the VAV boxes open during this mode of operation can cause unit shutdown and/or damage to the ductwork due to overpressurization.



***The VAV Heat Relay Output cannot exceed a current draw of 20VA. If the power requirements of the VAV boxes exceed this amount, isolation relays must be field supplied and installed to prevent overloading the Unit Controller power supply.***

## RETURN AIR BYPASS DAMPER

Units built with the FlexSys option will have an opening in the base of the unit between the evaporator coil and the supply air blower. A FlexSys unit requires a means to bypass return air and mix it with the air off the evaporator coil. Johnson Controls does have a special curb with the return duct bypass built into the curb. The purpose of the damper is to temper the supply air to the under floor system by mixing return air with the air off the evaporator coil. After the system is initialized, the mixed air damper modulates based on the ratio of the difference between the mixed air temperature minus the supply air temperature compared to the return air temperature minus the supply air temperature. As the mixed air temperature decreases, the damper opens allowing more air to bypass the evaporator coil resulting in a higher mixed air temperature supply to the under floor system.

The mixed air damper must be wired and installed into the system in the field. The wires to connect the actuator are located in the supply fan section, in the proximity of the actuator in the supply fan section floor, opposite the supply fan motor side. The plug assembly/wires are attached with an elastic band and must be wired to the actuator, and the “plugs” mated together. Connect the wires to the motor as follows:

- Wire labeled “412” to “com” terminal on the actuator.
- Wire labeled “301” to “pwr” terminal on the actuator.
- Wire labeled “411” to “sig” terminal on the actuator.

## BACnet COMMUNICATION

The Packaged Rooftop Unit can communicate to any building automation system using BACnet MSTP communication protocol.

The field connections are made by connecting shielded two-wire cable to Port 1 on the IPU control board.

Refer to *Communication on page 151* for additional information.

## DIRTY FILTER SWITCH

On units with a dirty filter switch option, an adjustable differential pressure switch is installed to monitor the pressure drop across the filters. When the pressure drop across the filters exceeds the setting of the switch the switch closes sending a 24-volt signal to the Unit Controller. The Unit Controller posts a warning in the service memory buffer; but will not shut down the unit.

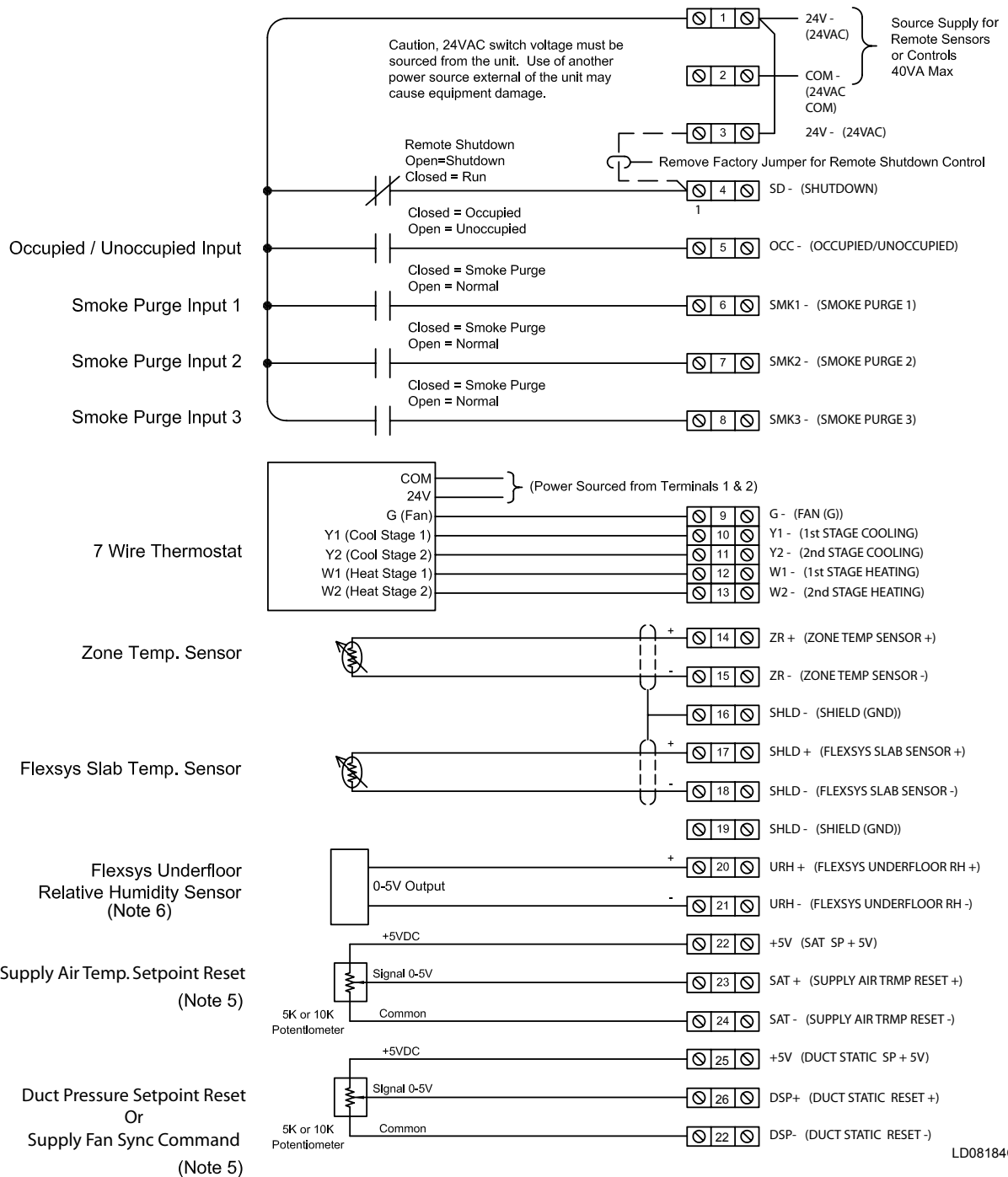
## ALARM CONTACTS

The Unit Controller has three sets dry Alarm Contacts that are closed during a fault. If the unit experiences a Supply Fan Fault, the Unit Controller will close a set of dry contacts between terminals 28 and 29 of the low voltage terminal block (CTB1). If the unit experiences a Cooling/Heating Fault, the Unit Controller will close a set of dry contacts between terminals 30 and 31 of the low voltage terminal block (CTB1). If the unit experiences a Sensor/Misc. Fault, the Unit Controller will close a set of dry contacts between terminals 32 and 33 of the low voltage terminal block (CTB1).

## POWER WIRING

Field wiring to the unit must conform to provisions of National Electrical Code (NEC) ANSI / NFPA 70-Latest Edition and / or local ordinances. The unit must be electrically grounded in accordance with the NEC and / or local codes. Voltage tolerances, which must be maintained during starting and running conditions, are indicated on the unit data plate.

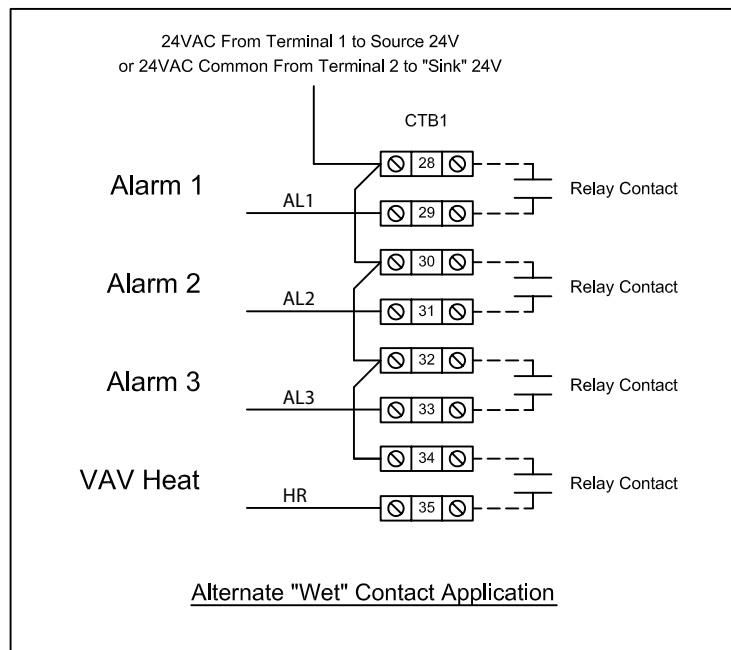
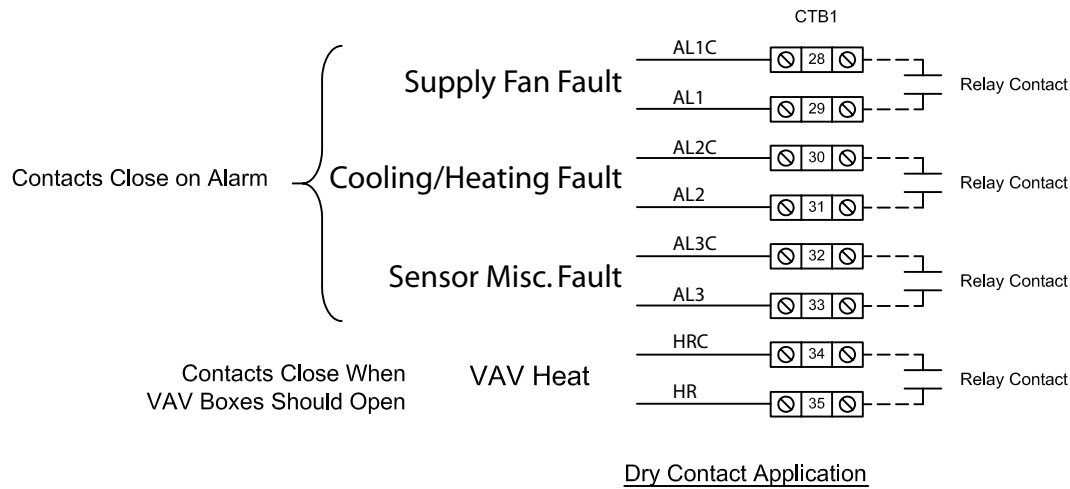
The internal wiring harnesses furnished with this unit are an integral part of the design certified unit. Field alteration to comply with electrical codes should not be required. If any of the wire supplied with the unit must be replaced, replacement wire must be of the type shown on the wiring diagram and the same minimum gauge as the replaced wire.



**Wiring Notes**

1. Wiring shown indicates typical wiring.
2. All wiring is Class 2, low voltage.
3. Maximum power available from the 24VAC terminal is 40VA.
4. Use shielded wire where shown.
5. Potentiometer application shown. As an alternative, signal inputs can be driven from an analog output of a third party controller. Note: Input resistance is 15 K ohms.
6. The FlexSys Underfloor Relative Humidity Sensor is field supplied. In addition to two wires which transmit the 0 to 5VDC signal from the sensor to the Unit Controller, the Underfloor Relative Humidity Sensor will also need to be powered. The type of voltage required to power the sensor will depend on the sensor selected. If the sensor uses 24VAC additional wires will need to be run to terminal 1 (24VAC) and terminal 2 (24VAC COM) of the CTB1 terminal block. If the sensor required a different power source than 24VAC it will need to be field supplied.

**FIGURE 15 - FIELD CONTROL WIRING - INPUTS**



LD08186B

Wiring Notes:

1. Wiring shown indicates typical wiring.
2. All wiring is Class 2, low voltage.
3. Maximum power available from the 24VAC terminal is 40VA.
4. Use shielded wire where shown.
5. Relay contacts suitable for pilot duty to 1A from 24VAC to 120VAC.

**FIGURE 16 - FIELD CONTROL WIRING - OUTPUTS**

Power supply to the unit must be NEC Class 1 and must comply with all applicable codes. A disconnect switch must be provided (factory option available). The switch must be separate from all other circuits. Wire entry at knockout openings requires conduit fittings to comply with NEC and/or Local Codes.

*Refer to Figures 17, 18 and 19 starting on page 48 for typical field wiring and to the appropriate unit wiring diagram mounted inside control doors for control circuit and power wiring information.*

### ELECTRICAL SERVICE SIZING

Electrical service is required for the cooling-only Packaged Rooftop Unit; use the appropriate calculations listed below from U.L. 1995. Based on the operating mode and configuration of the rooftop, the calculations will yield different MCA (minimum circuit ampacity), and MOP (maximum overcurrent protection). **MCA and Overcurrent Protection Device Data is supplied on the unit data plate.** *Also refer to Tables 8, 10, 11, 12, 13, 14 and 15 starting on page 39.*

The following calculations apply to electrical data for the rooftop unit. All concurrent load conditions must be considered in the calculations, and you must use the highest value for any combination of loads.

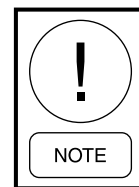
**Minimum Circuit Ampacity (MCA)** is based on 125% of the rated load amps for the largest motor plus 100% of the rated load amps for all other loads included in the circuit, per N.E.C. Article 440-34.

The minimum recommended disconnect switch is based on 115% of the rated load amps for all loads included in the circuit, per N.E.C.

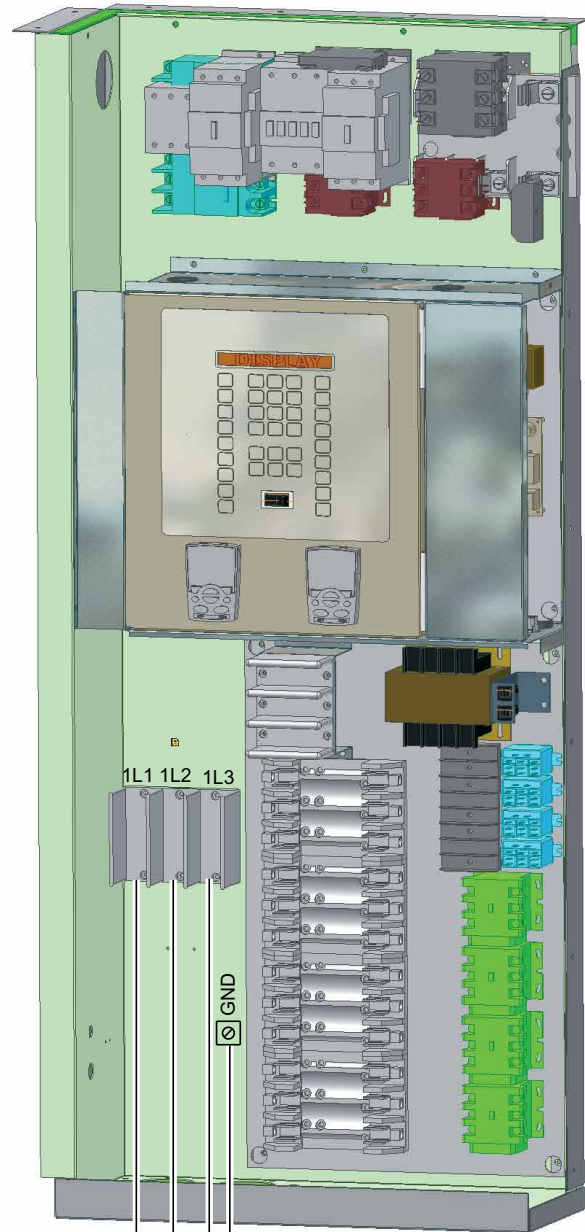
**Maximum overcurrent protection** is based upon 225% of the rated load amps for the largest motor plus 100% of the rated load amps for all other loads included in the circuit, per N.E.C. Article 440-22. If the maximum overcurrent protection does not equal a standard current rating of an overcurrent protective device, then the marked maximum rating is to be the next lower standard rating. However, if the device selected for maximum overcurrent protection is less than the MCA, then select the lowest standard maximum fuse size greater than or equal to the MCA.

Figures 17, 18 and 19 starting on page 48 show the power wiring that must be field supplied and installed. *See Table 17 on page 51 for the allowable conductor wire size for the electrical lugs in the unit.*

For dual point power connections, TB1 in the power panel supplies the all unit compressors and condenser fans. TB2 in the power panel supplies power to the unit supply, return and exhaust fans, and control circuitry.

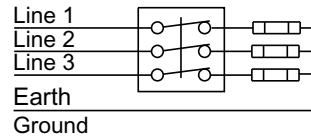


***All wiring must conform to the National Electrical Code (NEC) and local codes that may be in addition to NEC.***



LD13003

Field Power Supply

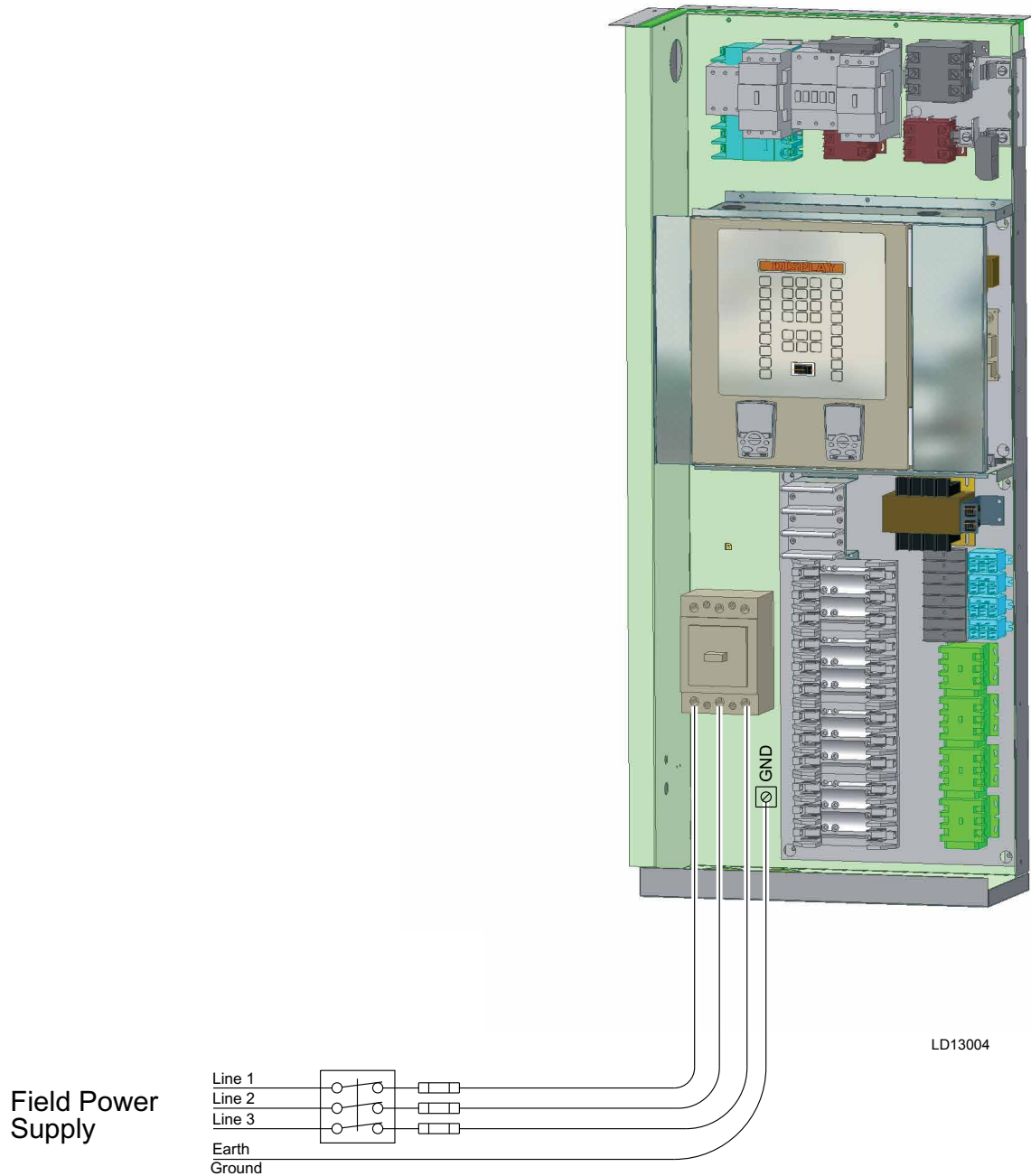


**NOTES:**

1. All field wiring must be provided through a field-supplied fused disconnect switch to the unit terminals (or optional molded disconnect switch).
2. All electrical wiring must be made in accordance with all N.E.C. and/or local code requirements.
3. Minimum Circuit Ampacity (MCA) is based on U.L. Standard 1995, Section 36.14 (N.E.C. Section 440-34).
4. Maximum Dual Element Fuse size is based on U.L. Standard 1995, Section 36.15 (N.E.C. Section 440-22).
5. Use copper conductors only.

**FIGURE 17 - SINGLE-POINT POWER SUPPLY WIRING**

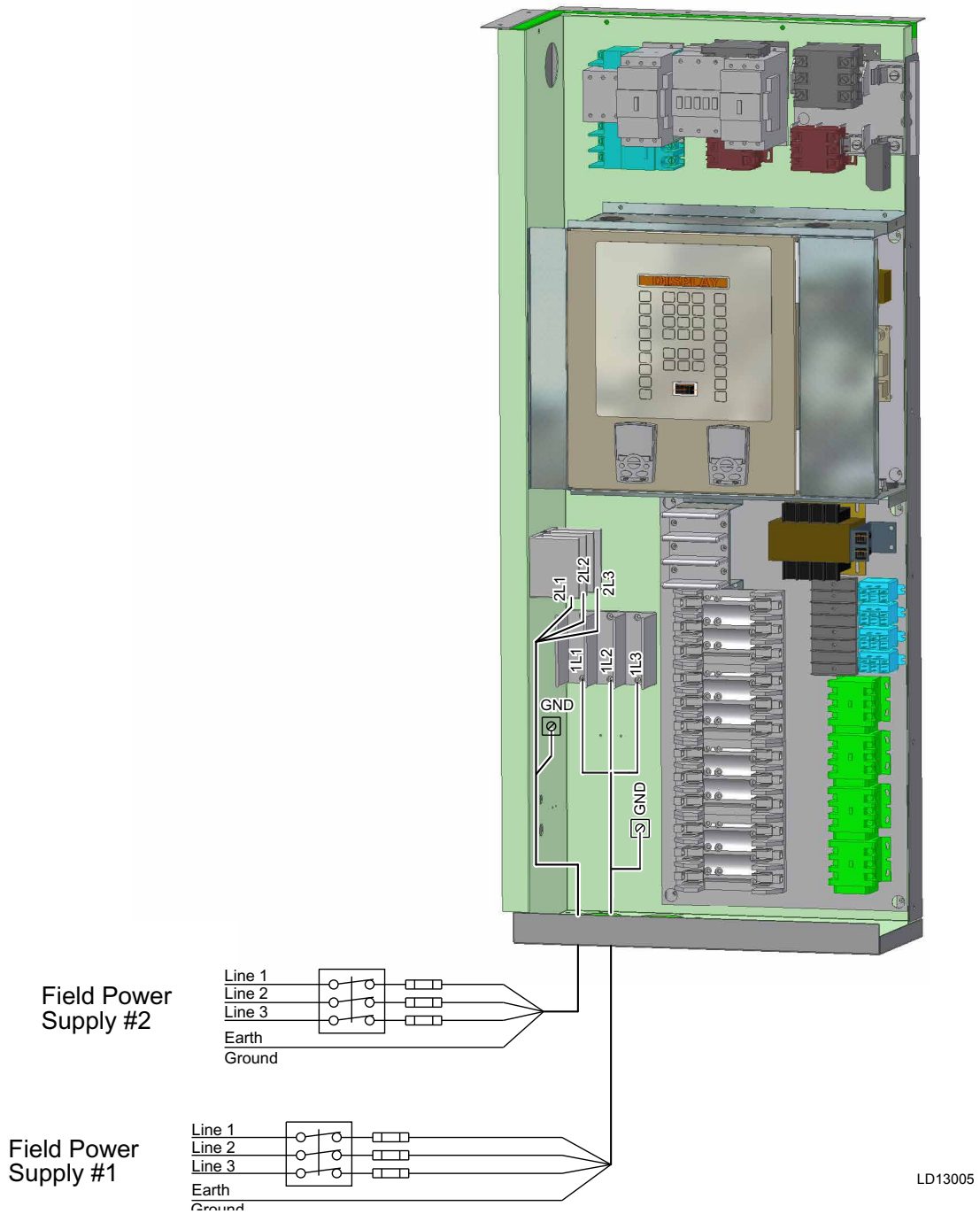




**NOTES:**

1. All field wiring must be provided through a field-supplied fused disconnect switch to the unit terminals (or optional molded disconnect switch).
2. All electrical wiring must be made in accordance with all N.E.C. and/or local code requirements.
3. Minimum Circuit Ampacity (MCA) is based on U.L. Standard 1995, Section 36.14 (N.E.C. Section 440-34).
4. Maximum Dual Element Fuse size is based on U.L. Standard 1995, Section 36.15 (N.E.C. Section 440-22).
5. Use copper conductors only.
6. On units with an optional disconnect switch, the supplied disconnect switch is a "Disconnecting Means" as defined in the N.E.C. Section 100, and is intended for isolating the unit from the available power supply to perform maintenance and troubleshooting. This disconnect switch is not intended to be a Load Break Device.

**FIGURE 18 - SINGLE-POINT POWER SUPPLY WIRING WITH NON-FUSED DISCONNECT**



**NOTES:**

1. All field wiring must be provided through a field-supplied fused disconnect switch to the unit terminals (or optional molded disconnect switch).
2. All electrical wiring must be made in accordance with all N.E.C. and/or local code requirements.
3. Minimum Circuit Ampacity (MCA) is based on U.L. Standard 1995, Section 36.14 (N.E.C. Section 440.34).
4. Maximum Dual Element Fuse size is based on U.L. Standard 1995, Section 36.15 (N.E.C. Section 440.22).
5. Use copper conductors only.

**FIGURE 19 - DUAL-POINT POWER SUPPLY WIRING**

**CONTROLS**

**TABLE 17 - THREE PHASE POWER SUPPLY CONDUCTOR SIZE RANGE 050-061 MODELS**

SUPPLY VOLTAGE	SINGLE POINT TB	SINGLE POINT DISCONNECT	DUAL POINT TB TB 1	TB 2
208V	(2*) 250 kcmil-500 kcmil	(2*) 2 AWG-500 kcmil	6 AWG-400 kcmil	6 AWG-350 kcmil
230V	(2*) 250 kcmil-500 kcmil	(2*) 2 AWG-500 kcmil	6 AWG-400 kcmil	6 AWG-350 kcmil
380V-60	6 AWG-400 kcmil	6 AWG-350 kcmil	14 AWG-2/0	14 AWG-2/0
460V	6 AWG-400 kcmil	6 AWG-350 kcmil	14 AWG-2/0	14 AWG-2/0
575V	6 AWG-400 kcmil	6 AWG-350 kcmil	14 AWG-2/0	14 AWG-2/0

**TRANSDUCER PNEUMATIC TUBING**

**Static Pressure Control Plastic Tubing (Pneumatic Tubing)**

Duct static transducers (all VAV units) and any unit with an optional building pressure control transducer, require pneumatic tubing to be field supplied and installed. Both the duct static transducer (VAV only) and optional building pressure transducer are mounted behind the right hand damper door. All wiring from the transducers is factory installed.

**Duct Static Transducer**

Plastic tubing (3/16" ID) must be run from the high pressure tap of the transducer to a static pressure tap (field supplied) in the supply duct, located at a point where constant pressure is desired. This is normally 2/3rds of the way down the duct, before the first take off.

**Building Pressure Transducer**

Plastic tubing (3/16" ID) must be run from the high pressure tap of the building static pressure transducer to a static pressure tap (field supplied), located in the conditioned space. The tap should be placed in a location where over pressurization will cause a problem, for example, in the lobby area where excessive pressure will cause the doors to remain open. The tap should never be placed above the ceiling.

This will allow for standard building pressure control through the unit controller. There is an option to control the VFD Driven Exhaust Fan speed through the BAS, if desired. If the unit has a return fan, the same

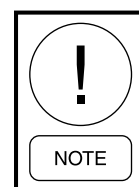
point can be used to control the Modulating Exhaust Damper. The point for BAS control can be enabled in the Service key.

**Static Pressure Probe Installation**

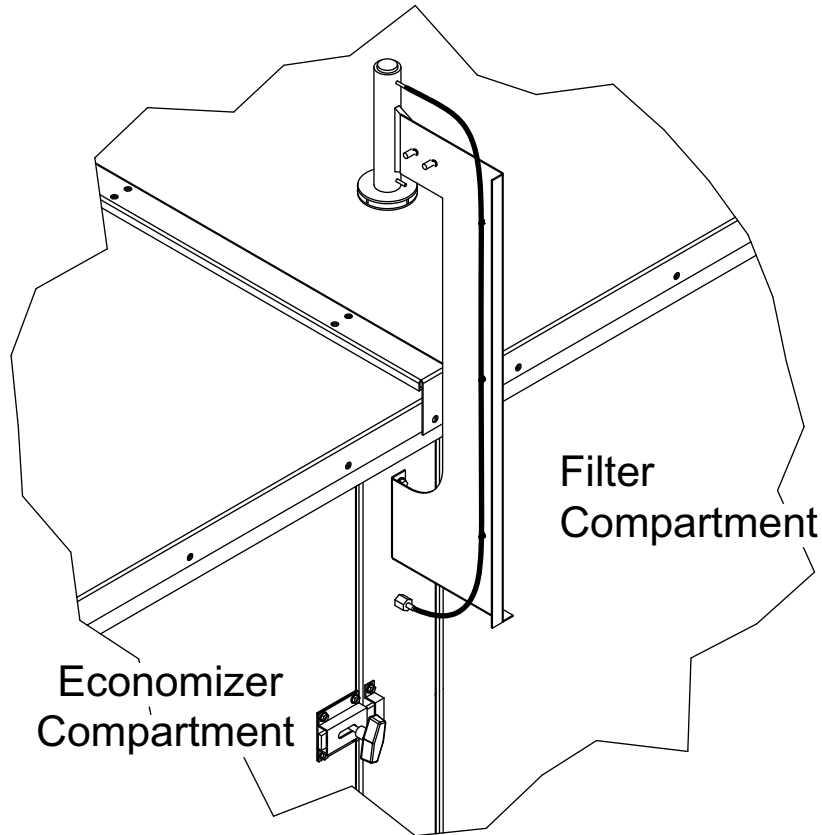
On units with duct static transducers (VAV units) and any unit with an optional building pressure, a factory supplied Static Pressure Probe must be field installed at the top of the rear corner post on the unit - see *Figure 20 on page 52*.

The factory supplied atmospheric pressure probe and associated mounting hardware are shipped inside the unit control panel. The hardware consists of a mounting bracket and a short section of pneumatic tubing. *The pneumatic tubing must be field installed from a factory pressure tap (next to the mounting location for the static pressure probe) to the atmospheric pressure probe (see Static Pressure Probe Installation Instructions, Form 100.50-N1).*

If the unit is equipped with both a building pressure transducer and a duct static transducer, a "tee" will be factory installed, and both the duct static pressure transducer and building pressure will be connected to the "tee" - both building static pressure transducer and duct static transducer will use the same factory supplied atmospheric pressure probe.



***The "low" side connection of the duct static or building pressure transducers are shipped with the pneumatic tubing factory installed and routed, to the external factory pressure tap.***



LD13127

The atmospheric probe should be mounted on the support post on the control side of the unit between the Economizer and the Filter compartment.

**FIGURE 20 - ATMOSPHERIC SENSOR PROBE**

**TABLE 18 - SUPPLY AIR DUCT CONNECTION CONFIGURATIONS**

UNIT CONFIGURATION		SUPPLY AIR		
		BOTTOM	LEFT	RIGHT
50-61 TONS	Cooling only	✓	✓	✓
	Cool/gas heat 1125 mbh	✓	N/A	N/A

Gas Heat not available with External Cabinet

**TABLE 19 - RETURN AIR DUCT CONNECTION CONFIGURATIONS**

UNIT CONFIGURATION		RETURN AIR		
		BOTTOM	LEFT	FRONT
50-61 TONS	NO EXHAUST	✓	✓	✓
	BAROMETRIC RELIEF DAMPER	✓	✓	N/A
	POWERED EXHAUST FAN	✓	✓	N/A
	RETURN FAN	✓	N/A	N/A

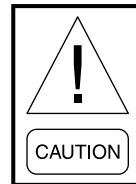
**DUCT SYSTEM**

**Duct Connection Guidelines**

All intake and discharge air duct connection to the unit may be made directly to the unit. These air duct connections should be on flexible material and should be installed so they are sufficiently loose. Duct runs and transitions must be made carefully to hold friction loss to a minimum. Avoid short turns, and duct elbows should contain splitters or turning vanes.

Duct work connected to the fan discharge should run in a straight line for at least **two** equivalent outlet diameters. Never deadhead the discharge into the flat surface of a plenum.

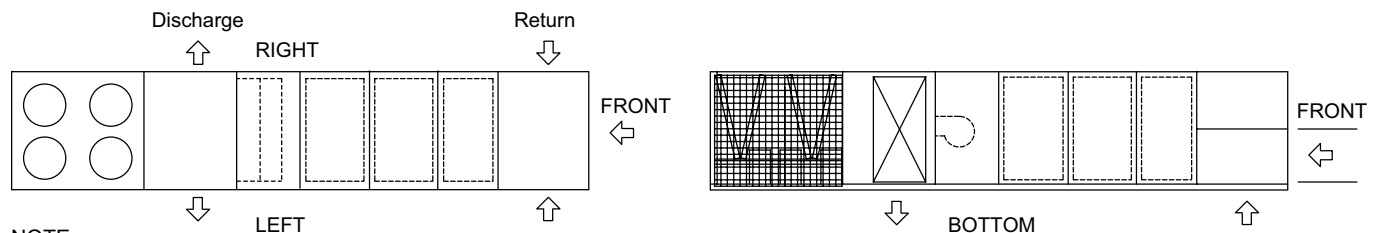
Refer to *Table 18 on page 53 and Table 19 on page 53* for available supply and return air duct connection configuration.



*Installation of elbows, discharge damper and other abrupt flow area changes installed directly at the fan outlet will cause system losses. These losses must be taken into account during the design phase and must be added to any field measurements.*

**SOUND AND VIBRATION TRANSMISSION**

All roof mounted air handling units generate some sound and vibration, which may or may not require some special treatment of the air conditioned space. The noise generated by the air handling unit is dependent on the speed of the fan, the amount of air the fan is moving, the fan type and the static efficiency of the fan. In applications where sound and vibration transmissions may be objectionable, good acoustical engineering practices must be incorporated in the system design.



NOTE:

This diagram is provided as a visual reference of the Series 100 discharge and return air openings and locations for all sizes. Please refer to the dimensional data for exact size and location of panels and openings.

LD08045

**FIGURE 21 - DISCHARGE AND RETURN AIR OPENINGS**

The Packaged Rooftop Unit is designed for lower sound levels than competitive units by using flexible fan connections, fan spring isolators, double-wall construction, multiple fan options, and lower speed and horsepower fans. For VAV applications, VFDs are used instead of inlet guide vanes. Additional sound attenuation can be obtained using compressor sound blankets and field-supplied sound attenuators when necessary.

Even with these equipment design features, the acoustical characteristics of the entire installation must never be overlooked. Additional steps for the acoustical characteristics of a rooftop installation should be addressed during the design phase of a project to avoid costly alterations after the installation of the equipment. During the design phase of a project, the designing engineer should consider, at a minimum, the impact of the equipment location, rooftop installation, building structure, and duct work.

**GAS HEATING**

**Gas Piping**

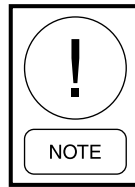
Proper sizing of the gas piping depends on the cubic feet per hour of gas flow required, specific gravity of the gas and the length of run. National Fuel Gas Code Z223.1 – latest Edition should be followed in all cases unless superseded by local codes or gas company requirements. Refer to *Table 20 on page 54*.

**TABLE 20 - PIPE SIZES**

LENGTH IN FEET	NOMINAL IRON PIPE SIZE	
	1-1/2 IN. <sup>1</sup>	2 IN. <sup>1</sup>
10	1,600	3,050
20	1,100	2,100
30	890	1,650
40	760	1,450
50		1,270
60		1,150
70		1,050
80		990

<sup>1</sup> Maximum capacity of pipe in cubic feet of gas per hour (based upon a pressure drop of 0.3 inch water column and 0.6 specific gravity gas).

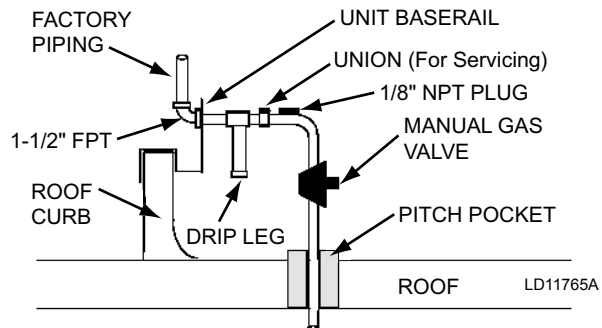
The heating value of the gas may differ with locality. The value should be checked with the local gas utility.



*There may be a local gas utility requirement specifying a minimum diameter for gas piping. All units require a 1-1/2-inch pipe connection at the entrance fitting. Line size should not be sized smaller than the entrance fitting size.*

**Gas Connection**

The gas supply line should be routed within the space and penetrate the roof at the gas inlet connection of the unit. The gas piping can enter the unit through an opening in the base of the gas heat section. Many local codes require that a shut off valve be located external to the unit. In these cases it is easier to run the gas piping on the roof and enter the unit through the side of the base rail. Typical supply piping arrangements are shown in *Figure 22 on page 54*.



**FIGURE 22 - TYPICAL GAS PIPING CONNECTION**

**Gas Piping Recommendations**

4. A drip leg and a ground joint union must be installed in the gas piping.
5. When required by local codes, a manual shut-off valve will have to be installed outside of the unit.
6. Use wrought iron or steel pipe for all gas lines. Pipe dope should be applied sparingly to male threads only.



*Natural gas may contain some propane. Propane being an excellent solvent will quickly dissolve white lead or most standard commercial compounds. Therefore, a special pipe dope must be applied when wrought iron or steel pipe is used. Shellac base components such as Gaskolac or Stalastic, and compounds such as Rectorseal #5, Clyde's or John Crane may be used.*

7. All piping should be cleaned of dirt and scale by hammering on the outside of the pipe and blowing out the loose particles. Before initial start-up, be sure that all of the gas lines external to the unit have been purged of air.
8. The gas supply should be a separate line and installed in accordance with all safety codes as prescribed under "Limitations" listed in the beginning of this section. After the gas connections have been completed, open the main shutoff valve admitting gas pressure to the mains. Check all joints for leaks with soap solution or other material suitable for the purpose. **NEVER USE A FLAME!**
9. The furnace and its individual manual shut-off valve must be disconnected from the gas supply piping system during any pressure testing of that system at test pressures in excess of 0.5 psig.

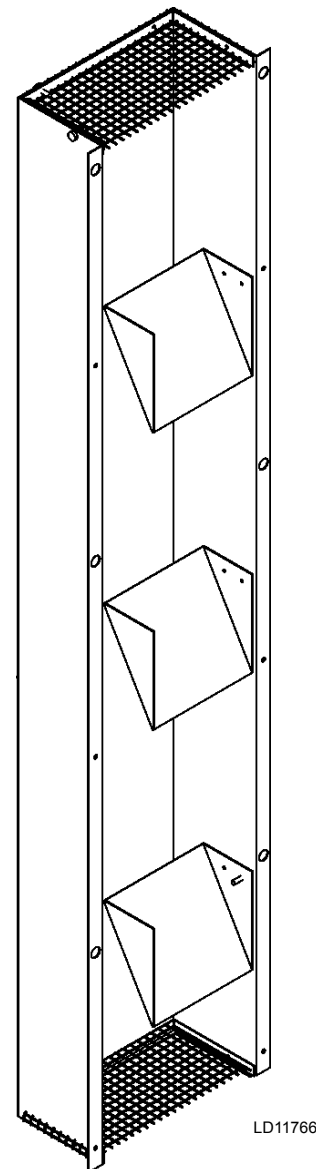


*Disconnect gas piping from unit when leak testing at pressures greater than 0.5 psig. Pressures greater than 0.5 psig will cause gas valve damage resulting in a hazardous condition. If gas valve is subjected to pressure greater than 0.5 psig, it must be replaced.*

10. A 1/8 inch N.P.T plugged tapping, accessible for test gage connection, must be installed immediately upstream of the gas supply connection to the furnace.

### Combustion Vent

The combustion vent assembly is shipped in the return air section of the unit. The combustion vent assembly must be mounted over the flue gas outlet fixed panel located to the right of the gas heat access door. Install as follows:



**FIGURE 23 - COMBUSTION VENT**

1. Remove the combustion vent assembly from the return compartment.
2. Remove the vertical row of six screws on either side of the flue gas outlet fixed panel.
3. Mount the combustion vent assembly over the flue gas outlets and attach to the gas outlet fixed panel using the screws removed in step 2.
4. See *Figure 23 on page 55* for the proper orientation of the combustion vent. The internal baffle(s) must direct the flue gases upward.

THIS PAGE INTENTIONALLY LEFT BLANK



## SECTION 3 – START-UP



*To protect warranty, this equipment must be installed and serviced by an authorized Johnson Controls service mechanic or a qualified service person experienced in air handling and condenser unit installation. Installation must comply with all applicable codes, particularly in regard to electrical wiring and other safety elements such as relief valves, HP cut-out settings, design working pressures and ventilation requirements consistent with the amount and type of refrigerant charge.*

*Lethal voltages exist within the Control Panel. Before servicing, open and tag all disconnect switches.*

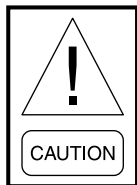
*Reference Start-up Guide, Form 100.50-SU5 for additional information*

### CRANKCASE HEATERS

With power applied to the rooftop unit, the crankcase heater for each compressor will be ON whenever the compressor is not running. The heater is interlocked into the compressor motor contactor and is not controlled by the microprocessor.

The purpose of the crankcase heater is to prevent the migration of refrigerant to the crankcase during shutdown, assuring proper lubrication of the compressor on start-up.

Anytime power is removed from the unit for more than an hour, the crankcase heater should be left on for 24 hours prior to start.



*Power must be applied to the rooftop unit 24 hours prior to starting the unit compressors. Failure to observe this requirement can lead to compressor damage and voiding of the compressor warranty.*

### CHECKING THE SYSTEM PRIOR TO INITIAL START (NO POWER)

#### Unit Checks

1. Inspect the unit for shipping or installation damage.
2. Visually check for refrigerant piping leaks.
3. The compressor oil level should be maintained so that an oil level is visible in the sight glass. The oil level can only be tested when the compressor is running in stabilized conditions, guaranteeing that there is no liquid refrigerant in the lower shell of the compressor. In this case, the oil must be between 1/4 and 3/4 in the sight glass. At shutdown, the oil level can fall to the bottom limit of the oil sight glass.
4. Check the control panel to assure it is free of foreign material (wires, metal chips, etc.).
5. Visually inspect field wiring (power and control). Wiring MUST meet N.E.C. and local codes.
6. Check tightness of terminal lugs inside the power panel on both sides of the contactors, overloads, fuses, and power connections.
7. Verify fuse sizing in main circuits.
8. Verify field wiring for thermostat (if applicable), optional zone sensor, etc.
9. Verify all applicable pneumatic tubing has been field installed for duct static pressure transducers (VAV units), optional building pressure transducer for power exhaust option, and outdoor static pressure probe.
10. Supply exhaust and return fan isolators spring bolts are removed (refer to *Figure 24 on page 58*).
11. Verify proper bearing and locking collar torque values on supply and exhaust fans (refer to *SECTION 4 – MAINTENANCE*).
12. Verify proper drive alignment of supply and exhaust fans (refer to *SECTION 4 – MAINTENANCE*).



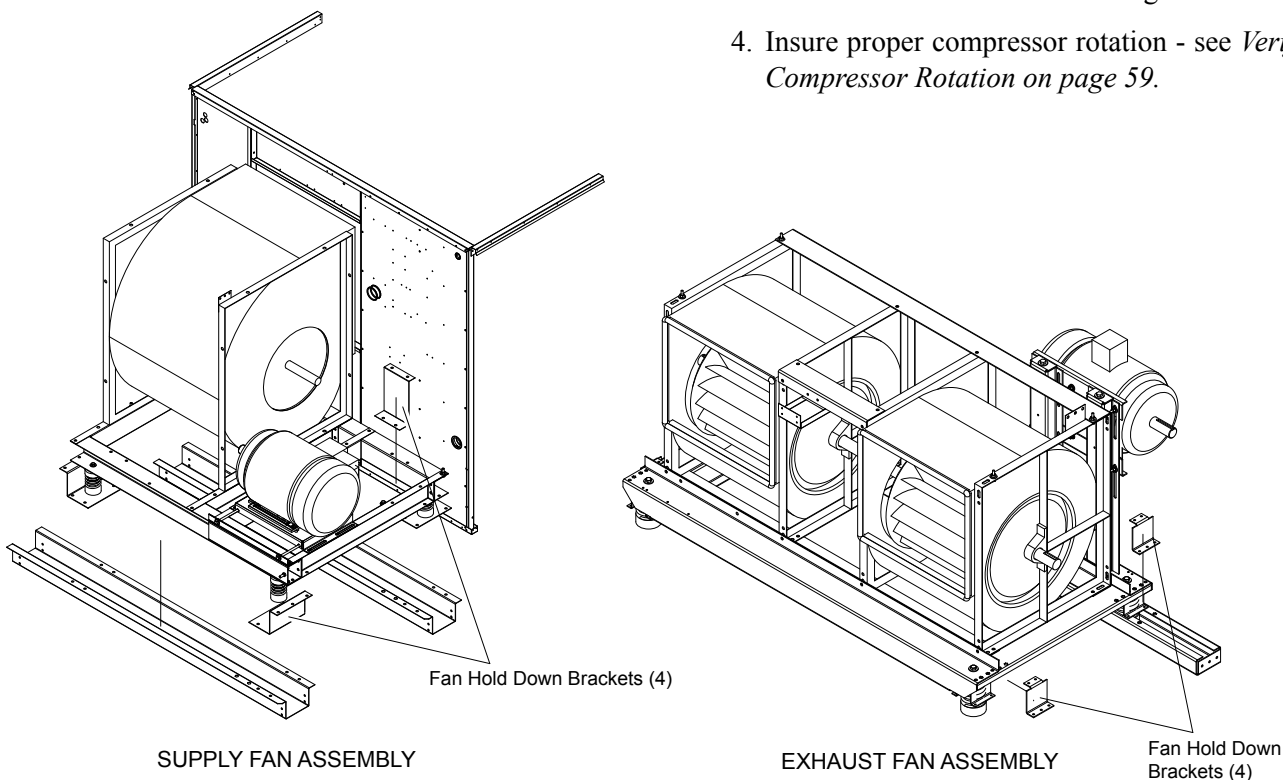
**The supply, exhaust and return fans have tie down bolts installed at the factory to prevent movement in the fan assemblies during shipment. THESE HOLD DOWN BOLTS MUST BE REMOVED PRIOR TO OPERATION OF THE ABOVE FANS. There are eight bolts per assembly two at each corner of the fan skirts, front and rear. The bolt locations are shown in Figure 22. The bolt heads are red in color and a label identifies their location in the unit.**

13. Verify proper belt tension of supply fan, exhaust fan or return fan (refer to *SECTION 4 – MAINTENANCE*). Belts must be checked after 24 hours of initial operation.
14. Manually rotate condenser fan blades, supply exhaust and return blower wheels and motors, to assure freedom of movement.
15. Verify proper condensate drain trap installation (refer to *Figure 24 on page 58*). Fill traps with water prior to unit start-up.

16. If applicable, verify installation of air filters (refer to *SECTION 2 – INSTALLATION* for size and quantity).
17. Verify Variable Frequency Drive setpoints for VAV unit Supply Fan and optional Variable Frequency Drive Exhaust and/or Return Fan drives. The Supply Fan VFD is located to the right of the electrical control box in the supply fan blower compartment.
18. If equipped, open suction line ball valve, discharge line ball valve, and liquid line ball valve for each refrigerant system.

#### UNIT CHECKS – POWER APPLIED

1. Apply 3-phase power and verify its value. Voltage imbalance should be no more than 2% of the average voltage.
2. Ensure that power phase monitor is set correctly. Voltage should be set for nameplate voltage, not actual voltage. Reset delay should be set approximately 1/4 of the way between 2 seconds and 70 seconds (this will be approximately 10-20 seconds).
3. Verify correct fan rotation – fan should rotate in direction of arrow on fan housing.
4. Insure proper compressor rotation - see *Verifying Compressor Rotation on page 59*.



**FIGURE 24 - FAN HOLD DOWN BRACKETS**

LD13268

### Verifying Compressor Rotation



*This unit uses scroll compressors, which will only operate in one direction. Failure to observe these steps could lead to compressor failure.*

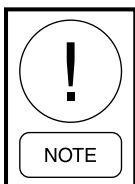
The Packaged Rooftop Unit uses hermetic scroll compressors, which only pump in one direction. Therefore, it is necessary to verify proper rotation at unit start-up. Operation of the compressor in the reverse direction will not pump, and cause the compressor to cycle on internal overload. Operating the compressor in reverse for “extended” periods can result in failure of the compressor.

To verify proper rotation, monitor the suction and discharge pressures of the respective refrigerant circuit when the compressor cycles ON. If the discharge pressure increases and suction pressure decreases as the compressor cycles ON, the compressor is properly phased and operating in the correct rotation.

Suction and discharge pressure may be monitored with the User Interface if the optional suction and discharge pressure transducers are installed (*refer to SECTION 6 – USER INTERFACE CONTROL CENTER*). If the optional transducers are not installed, pressures must be monitored with a manifold gauge connected to the service valves located on the suction and discharge lines.

### Compressor Oil Level Check

The oil level can only be tested when the compressor is running in stabilized conditions, to ensure that there is no liquid refrigerant in the lower shell of the compressor. When the compressor is running in stabilized conditions, the oil level must be between 1/2 and 3/4 in the oil sight glass.



*At shutdown, the oil level can fall to the bottom limit of the oil sight glass.*

### INITIAL START-UP

After all of the preceding checks have been completed and the control panel has been programmed as required, the unit may be placed into operation.

1. Place the Unit Switch in the control panel to the ON position.
2. With a demand, the supply fan will cycle ON, and permit compressor operation if the air proving pressure switch for the supply fan has closed.
3. The first compressor will start. After several minutes of operation, a flow of refrigerant will be noted in the sight glass, the vapor in the sight glass will clear, and there should be a solid column of liquid visible in the sightglass when the TXV stabilizes.
4. Allow the compressor to run a short time, being ready to stop it immediately if any unusual noise or adverse conditions develop.
5. Check the system operating parameters by checking evaporator superheat and condensing subcooling. Connect a gauge manifold set to the Schrader service valve connections on the liquid and common suction line in the condensing section of the unit. After the system is running and the pressures have stabilized, measure the temperature at the liquid and common suction lines near the Schrader service valves. Calculate evaporator superheat and condensing subcooling. The subcooling, should be approximately 15.0 °F and the superheat should be 12.0 °F. Refer to *Subcooling (R-410a) on page 60* for information on how to calculate evaporator superheat and condenser subcooling. Repeat the above process for each of the refrigerant systems.
6. With an ammeter, verify that each phase of the condenser fans, compressors, supply fan, and exhaust fan are within the RLA/FLA as listed on the unit data plate.

### Refrigerant Charge

This rooftop unit comes fully charged from the factory with refrigerant R-410a as standard.

**TABLE 21 - CONDENSER COIL PRESSURE DROP**

YPAL050	YPAL051	YPAL060	YPAL061
33 PSIG	39 PSIG	24 PSIG	27 PSIG

## Checking Superheat and Subcooling

An R-410a temperature and pressure chart lists the associated *saturation* temperature in one column, with the associated pressure in another column. As a result, only one temperature/pressure column is needed to show the relationship.

### Subcooling (R-410a)

When the refrigerant charge is correct, there will be no vapor in the liquid sight glass with the system operating under full load conditions.

The subcooling temperature of each system can be calculated by recording the temperature of the liquid line at the outlet of the condenser and subtracting it from the saturation temperature listed in *Table 22 on page 61*, for the corresponding discharge pressure. If the rooftop unit does not have an access port for liquid access, subtract the condenser coil pressure drop value in *Table 21 on page 59* from the discharge pressure to determine the liquid pressure. Convert that value to a saturation temperature in *Table 22 on page 61*. Subtract the liquid line temperature from the converted saturation temperature to determine Subcooling.

#### Example:

On a YPAL050, the discharge pressure is 388 PSIG and the liquid temperature is 95.0 °F.

Liquid Pressure = Discharge Pressure (388 PSIG)  
- 33.0 PSIG

Saturation Temperature for 355 PSIG = 108.0 °F

Minus the liquid line temp = 95.0 °F

Liquid Line Subcooling of = 13.0 °F

The subcooling should be 15.0 °F at design conditions.

## Superheat (R-410a)

The superheat should be checked only after steady state operation of the unit has been established, the discharge air temperature has been pulled down to within the control range, and the unit is running in a fully loaded condition.

The superheat is calculated as the difference between the actual temperature of the refrigerant gas in the suction line and the temperature corresponding to the Suction Pressure as shown in *Table 22 on page 61*.

#### Example:

The suction pressure is 130 PSIG and the suction line temperature is 57.0 °F.

Suction Line Temperature = 57.0 °F

Saturation Temperature for 130 PSIG = 45.0 °F

Evaporator Superheat = 12 °F

When adjusting the expansion valve, the adjusting screw should be turned not more than one turn at a time, allowing sufficient time (approximately 15 minutes) between adjustments for the system and the thermal expansion valve to respond and stabilize.

The superheat setting should be adjusted to 12.0 °F at design conditions.

## Leak Checking

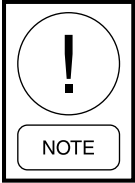
Leak check compressors, fittings and piping to assure no leaks. Verify the evaporator distributor tubes do not have bare copper touching each other or are against a sheet metal edge. If you are leak checking a unit charged with R-410a make sure the leak test device is capable of sensing refrigerant R-410a.

**If the unit is functioning satisfactorily during the initial operating period, no safeties trip and the unit controls are functioning properly, the rooftop unit is ready to be placed into operation.**

**TABLE 22 - R410-A PRESSURE / TEMPERATURE CHART**

PSIG	TEMP °F	PSIG	TEMP °F
0	-60	78	20
2	-58	80	21
4	-54	85	24
6	-50	90	26
8	-46	95	29
10	-42	100	32
12	-39	105	34
14	-36	110	36
16	-33	115	39
18	-30	120	41
20	-28	125	43
22	-26	130	45
24	-24	135	47
26	-20	140	49
28	-18	145	51
30	-16	150	53
32	-14	160	57
34	-12	170	60
36	-10	180	64
38	-8	190	67
40	-6	200	70
42	-4	210	73
44	-3	220	76
46	-2	225	78
48	0	235	80
50	1	245	83
52	3	255	85
54	4	265	88
56	6	275	90
58	7	285	92
60	8	295	95
62	10	305	97
64	11	325	101
66	13	355	108
68	14	375	112
70	15	405	118
72	16	500	134
74	17	600	149
76	19	700	159

**3**

**Gas Heat Models**

*Installation of this furnace at altitudes above 2000 ft (610 m) shall be made in accordance with the High Altitude Accessory Kit Installation Instructions (100.50-N16) available with this furnace.*

*L'installation de ce générateur de chaleur à des altitudes supérieures à 610 m (2000 pi) doit être effectuée conformément aux instructions d'installation du kit d'accessoires de haute altitude (100.50-N16) fournie avec cet appareil.*

**ELECTRICAL SHOCK, FIRE, OR EXPLOSION HAZARD**

*Failure to follow safety warnings exactly could result in dangerous operation, serious injury, death, or property damage.*

*Improper servicing could result in dangerous operation, serious injury, death, or property damage.*

- *Before servicing, disconnect all electrical power to furnace.*
- *When servicing controls, label all wires prior to disconnecting. Reconnect wires correctly.*
- *Verify proper operation after servicing.*

**RISQUE D'ÉLECTROCUTION, D'INCENDIE OU D'EXPLOSION**

*Si les consignes de sécurité ne sont pas suivies à la lettre, cela peut entraîner la mort, de graves blessures, un fonctionnement dangereux ou des dommages matériels.*

*Un entretien inadéquat peut entraîner la mort, de graves blessures, un fonctionnement dangereux ou des dommages matériels.*

- *Avant de faire l'entretien de l'appareil de chauffage, le débrancher de l'alimentation électrique.*
- *Avant l'entretien des commandes, étiqueter tous les fils avant de les déconnecter. Rebrancher correctement les fils.*
- *Vérifier que l'appareil fonctionne correctement après l'entretien.*

**FIRE OR EXPLOSION HAZARD**

*Failure to follow safety warnings exactly could result in serious injury, death, or property damage.*

*Do not store or use gasoline or other flammable vapors and liquids in the vicinity of this or any other appliance.*

**WHAT TO DO IF YOU SMELL GAS**

- *Do not try to light any appliance.*
- *Do not touch any electrical switch; do not use any phone in your building.*
- *Leave the building immediately.*
- *Immediately call your gas supplier from a neighbor's phone. Follow the gas supplier's instructions.*
- *If you cannot reach your gas supplier, call the fire department.*

*Installation and service must be performed by a qualified installer, service agency, or the gas supplier.*

**RISQUE D'INCENDIE OU D'EXPLOSION**

*Si les consignes de sécurité ne sont pas suivies à la lettre, cela peut entraîner la mort, de graves blessures ou des dommages matériels.*

*Ne pas entreposer ni utiliser d'essence ni autres vapeurs ou liquides inflammables à proximité de cet appareil ou de tout autre appareil.*

**QUE FAIRE SI UNE ODEUR DE GAZ EST DÉTECTÉE**

- *Ne mettre en marche aucun appareil.*
- *Ne toucher aucun interrupteur électrique; ne pas utiliser de téléphone dans le bâtiment.*
- *Quitter le bâtiment immédiatement.*
- *Appeler immédiatement le fournisseur de gaz en utilisant le téléphone d'un voisin. Suivre les instructions du fournisseur de gaz.*
- *Si le fournisseur de gaz n'est pas accessible, appeler le service d'incendie.*

*L'installation et l'entretien doivent être effectués par un installateur ou une entreprise d'entretien qualifié, ou le fournisseur de gaz.*



### **FIRE OR EXPLOSION HAZARD**

*Failure to follow safety warnings exactly could result in serious injury, death, or property damage.*

*Never test for gas leaks with an open flame.*

*Use a commercially available soap solution made specifically for the detection of leaks to check all connections. A fire or explosion may result causing property damage, personal injury, or loss of life.*



### **RISQUE D'INCENDIE OU D'EXPLOSION**

*Si les consignes de sécurité ne sont pas suivies à la lettre, cela peut entraîner la mort, de graves blessures ou des dommages matériels.*

*Ne jamais vérifier la présence de fuites de gaz au moyen d'une flamme nue.*

*Vérifier tous les raccords en utilisant une solution savonneuse commerciale conçue spécialement pour la détection de fuites. Un incendie ou une explosion risque de se produire, ce qui peut entraîner la mort, des blessures ou des dommages matériels.*

## **Pre-Start Checks**

When starting up these units, it is imperative that ALL gas fittings within the unit (in addition to the field installed gas connections) are leak checked with a soap solution as part of the unit commissioning process. The heat section must be fired when checking the joints on the manifold side of the gas valve. If any leaks are detected, the leaks must be repaired immediately and all joints rechecked.

Verify wiring inside the burner compartment to insure the wiring/terminals are tight and securely connected to the components, such as the ignition control, flame sensor, gas valve, rollout switches and igniter.

The gas heat start up sequence begins with a 30 second prepurge. The next step in the sequence is the closure of the air proving switch. The heat section has a combustion air-proving switch. This switch must close before the ignition sequence can initiate. If the air-proving switch is closed after the 30 second prepurge the ignition control will energize the spark igniter and open the gas valve.

The furnace ignition control uses flame rectification as verification of burner operation. The minimum allowable flame current for operation is 0.7 DC microamps.

If the furnace ignition control does not prove flame in 7 seconds, it will turn off the spark signal and close the gas valve. It will wait 30 seconds and then initiate a second ignition sequence. If flame is not proven during the second 7 second trial for ignition the control will turn off the spark signal, close the gas valve, wait 30 seconds and initiate a third ignition sequence. If flame rectification is not proven on the third try, the ignition control will lock out.

The heat section has two roll out switches mounted above the burners. The purpose of the roll out switch is to protect the gas heat section from flame roll out, flame burning outside the heat exchanger. A restriction in the heat exchanger or breach in the flue passages could result in a roll out situation. The roll out switch is a manual reset device.

The unit has two high temperature limit switches. One located at the heat exchanger vestibule panel and the other located in the area of the heat exchanger return bend. These limits are automatic reset devices. If the limit opens the ignition control will de-energize the gas valve. On staged gas heat, as soon as the limit closes the ignition control will re-initiate the ignition sequence. If the limit opens on a modulating gas heat section the Unit Controller will lockout the heat section.

The control circuit is tested in the factory to insure that all of these steps are followed, however, natural gas is not actually introduced to the system in the plant; nitrogen is used in its place.

## **Post Start Checks**

When a signal is received at the gas heat control module from the Unit Controller, verify:

- Combustion blower starts and runs for 30 seconds before the spark is initiated.
- Spark igniter sparks.
- Gas valve opens.
- Burners light from right to left, in a 2.5 second time frame; that each one lights in sequential order from right to left; and establishes stable flame immediately upon ignition.
- Check for gas leaks in the unit piping as well as the supply piping.

- Check for correct manifold gas pressures. See *Manifold Gas Pressure Adjustment on page 64*
- Check the supply pressure. It must be within the limitations shown in *Table 23 on page 64*. Supply pressure should be checked with all gas appliances in the building at full fire. At no time should the standby gas pressure exceed 10.5 "W.C., nor the operating pressure drop below 4.5 "W.C. for natural gas or the standby gas pressure exceed 13.0 "W.C., nor the operating pressure drop below 11.0 "W.C. for propane. If the gas pressure is outside these limits, contact the installing mechanical contractor for corrective action.
- The flame is stable, with flame present only at the end of the burner, no burning is occurring inside the burner. There should be little yellow tipping of the flame.
- There may be some smoke through the flue, due to tooling oil burning off of the heat exchanger tubing.

### MANIFOLD PRESSURE – MODULATING GAS

**TABLE 23 - LOW FIRE (INDUCER FAN ON LOW, 1.4 "W.C. INPUT TO MAXITROL VALVE**

INPUT VOLTAGE TO SIGNAL CONDITIONER (VDC)	MANIFOLD PRESSURE ("W.C.)
0.0	0.22
0.5	0.22
1.0	0.22
1.5	0.22
2.0	0.22
2.5	0.32
3.0	0.45
3.5	0.66
4.0	0.84
4.5	1.05
5.0	1.25
5.5	1.30
6.0	1.30
6.5	1.30

**TABLE 24 - HIGH FIRE (INDUCER FAN ON HIGH, 3.5 "W.C. INPUT TO MAXITROL VALVE**

INPUT VOLTAGE TO SIGNAL CONDITIONER (VDC)	MANIFOLD PRESSURE ("W.C.)
4.0	1.10
4.5	1.40
5.0	1.70
5.5	2.10
6.0	2.50
6.5	2.90
7.0	3.15
7.5	3.25
8.0	3.30
8.5	3.30
9.0	3.30

### MANIFOLD PRESSURE – STAGED GAS

**TABLE 25 - LOW FIRE / HIGH FIRE PRESSURES**

TYPE OF GAS	LINE PRESSURE		MANIFOLD PRESSURE	
	MIN	MAX	LOW FIRE +/- 0.3 "W.C.	HIGH FIRE +/- 0.3 "W.C.
NATURAL	4.5 "W.C.	10.5 "W.C.	1.2 "W.C.	3.5 "W.C.
PROPANE	11.0 "W.C.	13.0 "W.C.	4.2 "W.C.	10.0 "W.C.

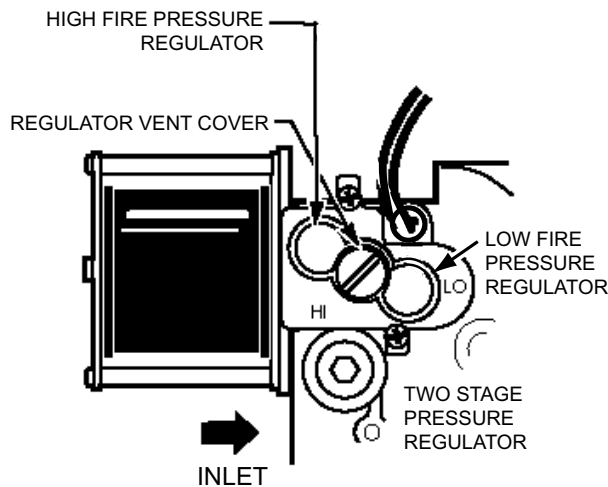
### Manifold Gas Pressure Adjustment

Small adjustments to the manifold gas pressure can be made by following the procedure outlined below. Refer to *Figure 25 on page 65* for the high and low fire pressure regulator adjustment locations.

1. Turn the gas off to the unit.
2. Use a 3/16 inch Allen wrench to remove the 1/8 inch NPT plug from the outlet pressure tap of the valve.
3. Install a brass adapter to allow the connection of a hose to the outlet pressure tap of the valve.
4. Connect the hose to a manometer capable of reading the required manifold pressure value.
5. Turn the gas back on.
6. Place the heat section into high fire operation.
7. Compare the high fire manifold pressure to *Table 25 on page 64*.



8. To adjust the high fire manifold pressure remove the cap from the high fire pressure regulator. Use a 3/32 Allen wrench to make the manifold pressure adjustment. To increase the manifold pressure, turn the screw clockwise; to decrease the manifold pressure, turn the screw counterclockwise. Place your finger over the adjustment opening while verifying the manifold pressure.
9. Place the heat section into low fire operation.



LD11760A

**FIGURE 25 - MANIFOLD GAS PRESSURE ADJUSTMENT**

10. Compare the low fire manifold pressure to *Table 25 on page 64*.
11. To adjust the low fire manifold pressure remove the cap from the low fire pressure regulator. Use a 3/32 inch Allen wrench to make the manifold pressure adjustment. To increase the manifold pressure, turn the screw clockwise; to decrease the manifold pressure, turn the screw counterclockwise. Place your finger over the adjustment opening while verifying the manifold pressure.
12. Turn the heat OFF.
13. Turn the gas OFF.
14. Remove the brass tubing adapter and replace the plug in the outlet pressure tap.

**3**

**TABLE 26 - GAS HEAT PERFORMANCE DATA**

UNIT	GAS INPUT CAPACITY (BTU/HR X 1000)	MAXIMUM OUTPUT CAPACITY (BTU/HR X 1000)	AIRFLOW		TEMP. RISE (°F)
			MIN.	MAX.	
50-61	375	300	11,00	24,000	15-25
	750	600	14,000	24,000	20-30
	1125	900	18,000	24,000	35-45

THIS PAGE INTENTIONALLY LEFT BLANK

## SECTION 4 – MAINTENANCE



***Make sure power is removed from the unit before performing the maintenance items contained in this section.***

### GENERAL

A planned program of regularly scheduled maintenance will return dividends by averting possible costly and unexpected periods of down time. It is the responsibility of the owner to provide the necessary maintenance for the air handling units and coils. If a system failure occurs due to improper maintenance during the warranty period, Johnson Controls will not be liable for costs incurred to return the unit to satisfactory operation.

### PERIODIC MAINTENANCE – MONTHLY

#### Filters

Check the cleanliness of the filters and replace or clean as required.

#### Linkages

Examine the damper and operator linkages to insure that each is free and operating smoothly.

#### Compressors

**Oil Level Check:** The oil level can only be tested when the compressor is running in stabilized conditions, to ensure that there is no liquid refrigerant in the lower shell of the compressor. When the compressor is running in stabilized conditions, the oil level must be between 1/4 and 3/4 in the oil sight glass. *Note: at shutdown, the oil level can fall to the bottom limit of the oil sight glass.*

**Oil Analysis:** Use York Type “V” POE oil (Copeland Ultra 32-3MAF) for units charged with R-410a refrigerant.

The type of refrigerant and amount per system is listed on the unit rating plate. A change in the oil color or odor may be an indication of contaminants in the refrigeration system. If this occurs, an oil sample should be taken and analyzed. If contaminations are present, the system must be cleaned to prevent compressor failure. This can be accomplished through the installation of oversized suction and liquid line driers. The driers may have to be changed several times to clean up the system depending on the degree of contamination.



***Never use the scroll compressor to pump the refrigerant system down into a vacuum. Doing so will cause internal arcing of the compressor motor, which will result in failure of compressor.***

### Fan Bearing Lubrication

Add grease slowly with shaft rotating until a slight bead forms at the seals. If necessary, re-lubricate while bearing is stationary. The fan data plate (attached to the fan scroll) lists the type of grease that must be used for lubricating the bearings. Refer to *Table 27 on page 67* for lubricating schedule.

Re-lubrication is generally accompanied by a temporary rise in operating temperature. Excess grease will be purged at seals.

### Recommended Lubricant For Fan Bearings

A Lithium/Petroleum base grease conforming to an NLGI Grade II consistency is normally used. Lubricant must be free of any chemical impurities such as free acid or free alkali, dust, rust, metal particles or abrasive. This light viscosity, low torque grease is rust inhibited and water resistant, has a temperature range of -30 °F to +200 °F with intermittent highs of +250 °F. Lubricate bearings as required by the severity of required duty.

**TABLE 27 - FAN BEARING – LUBRICATION INTERVALS**

RELUBRICATION SCHEDULE (MONTHS) BALL BEARING PILLOW BLOCKS									
SPEED (RPM)	500	1000	1500	2000	2500	3000	3500	4000	4500
SHAFT DIA									
1/2" thru 1-11/16"	6	6	5	3	3	2	2	2	1
1-15/16" thru 2-7/16"	6	5	4	2	2	1	1/2	1/4	1/4
2-11/16" thru 2-15/16"	5	4	3	2	1	1/2	1/2		
3-7/16" thru 3-15/16"	4	3	2	1	1/2	1/2			

## Condenser Coils

Dirt should not be allowed to accumulate on the condenser coil surfaces. Cleaning should be as often as necessary to keep coil clean.

### PERIODIC MAINTENANCE – THREE TO SIX MONTHS



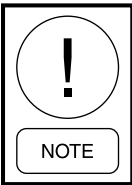
**Disconnect and lock-out power from the unit anytime service is being performed on the fan section. Failure to do so could result in serious injury or death due to the fan turning ON while work is in progress.**



**Squealing belts during starting is caused by slipping belts that are not tensioned properly.**

## Motor Bearing Lubrication

Bearings must be re-lubricated periodically to assure long life. Motor bearing should be lubricated yearly, but may need lubrication more frequently, depending on severe operating conditions.



**Removal of the relief plug on the motor bearing is required during greasing. Overgreasing the motor can cause bearing damage and will not be covered under unit warranty.**

## Belt Tension

Adjust the belt tension if necessary. Required belt tension data is supplied on the fan “skid” data plate, attached to the fan housing. Never use a belt dressing on the belts. If belts slip with the proper tension, use a good grade of belt cleanser to clean the belts. Refer to *Figure 27 on page 69*.



**Never use excessive belt tension, as this could result in damaging the bearing, motor pulleys or motor base. See drive label on fan housing adjacent to drive for specific details on tension.**

When it is necessary to replace one belt in a given set, the entire set of belts must be replaced.

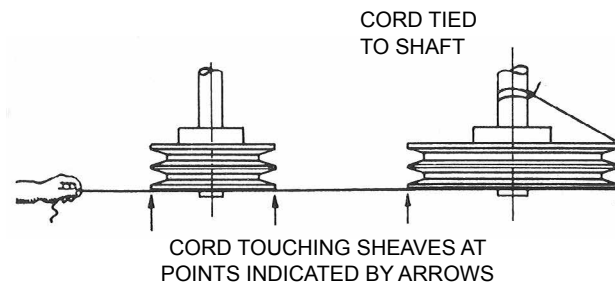
## PERIODIC MAINTENANCE – YEARLY

Check the fan wheels and inspect the drain pan for sludge and foreign material. Clean if required.

Observe the operation of all dampers and make any necessary adjustments in linkage and blade orientation for proper operation.

## Entire Unit Inspection

In addition to the checks listed in this section, periodic overall inspections of the unit should be accomplished to ensure proper equipment operation. Items such as loose hardware, component operation, refrigerant leaks, unusual noises, etc. should be investigated and corrected immediately.



**FIGURE 26 - SHEAVE ALIGNMENT**

## Sheave Alignment

To check sheave alignment, a straight edge or a piece of string can be used. If the sheaves are properly aligned, the string or straight edge will touch at all points, as indicated in *Figure 26 on page 68*. Rotating the sheaves will determine if the sheave is wobbly or the drive shaft is bent. Alignment error must be corrected to avoid bearing and belt failure.

## Belts

New belts should be re-checked after 24 hours of operation. On multiple belt adjustable pulleys, the pitch depth should be checked to insure identical belt travel, power transfer and wear. Adjustable motor bases are provided for belt adjustment.

Motor pulleys and blower shaft pulleys are locked in position with either set screws or split taper lock bushings. All set screws and/or taper lock bolts must be checked for tightness and alignment before putting equipment into operation.

An incorrectly aligned and tensioned belt can substantially shorten belt life or overload blower and motor bearings, shortening their life expectancy. A belt ten-

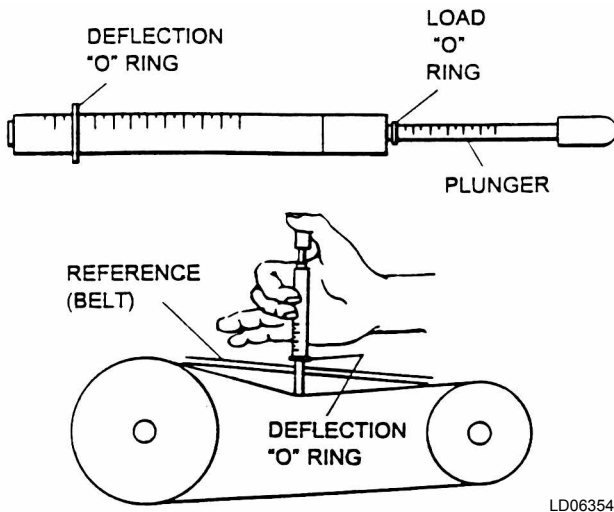
sioned too tightly can overload the motor electrical, causing nuisance tripping of the motor overloads and/or motor failure and/or shaft failure.

### Belt Replacement

Always replace belts as a set. Follow the steps below to replace belts:

- Release the tension on the belts by loosening the adjusting nuts on the fan motor.
- Remove old belts and recheck the sheave alignment with a straight edge.
- Install the new belts on the sheaves.

Never place the belts on the sheaves by using a screwdriver to pry the belt over the rim of the sheave. This will permanently damage the belts.



**FIGURE 27 - BELT TENSIONING GAUGE**

### Belt Tensioning

A Browning Belt tension gauge is used in *Figure 27* on *page 69* to properly tension belts.

### Filter Drier Replacement

The filter/drier should be replaced any time work is performed on the refrigerant circuit. The rooftop unit comes with sealed type (non-replaceable) cores as standard. If the unit is not equipped with the optional valve package (suction, discharge, and liquid line valves), the refrigerant will need to be recovered with a recovery machine to replace the filter/drier.

If the unit is equipped with a valve package, the unit can be pumped down by closing the liquid line ball valve (prior to the filter/drier) while the unit is run-

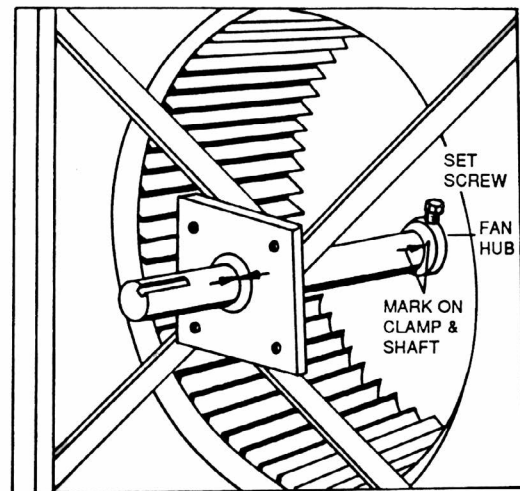
ning, initiating a unit pump-down. The unit will shut OFF when the mechanical low-pressure switch opens. When the unit shuts down, close the ball valve located after the filter/drier and remove power from the unit to prevent the unit from running. Once the filter/drier core has been replaced, the filter/drier section should be evacuated via the Schrader access valve located next to the filter/drier prior to opening the ball valves and restoring the unit to normal operation.



**Never shut the discharge valve while the unit is running. Doing so could cause a rupture in the discharge line or components, resulting in death or serious injury.**



**Never close the suction line ball valve with the compressor running. Doing so will cause the compressor to pump-down into a vacuum and damage the compressor due to internal arcing.**



**FIGURE 28 - EXAMPLE OF FC FAN SHAFT/WHEEL MARKING**

### Forward Curved Fans

The forward curved fan wheel must be removed through the fan discharge opening. The location of other clamps, fan wheel, and shaft must be marked so each of these components can be reassembled in the same location - see *Figure 28* on *page 69*. This will preserve the balance of the rotating assembly. Proceed with the following steps:

- Disconnect all duct work or guards attached to the blower housing to permit unobstructed access.

- Remove the cut off plate attached at the discharge or blast area of the blower housing.
- Thoroughly clean the shaft of all grease and rust inhibitor. Be careful not to contaminate the bearing grease. Use emery cloth to remove all rust or the wheel may become “locked” to the shaft.
- Loosen and remove set screws on both bearing locking collars. Inspect and, if necessary, replace.
- Loosen and remove set screws from both sides of the wheel hub. Inspect and, if necessary, replace.
- Using a rubber mallet or brass bar, slowly drive the shaft in one direction until the set screw marks on the shaft are fully exposed. File the marks completely smooth. Drive the shaft in the opposite direction and file smooth the set screw marks. Continue to clean the shaft of all dirt and residuals.
- To remove the key, use a rubber mallet or brass bar to drive the shaft and wheel in one direction. Drive the key in the opposite direction using a nail set or smaller size key stock until the key is completely free of the wheel. Be sure that key does not get bent by allowing it to ride up the key way edge. The slightest bend will prevent quick assembly. Should this occur, replace the key stock.
- Remove the shaft, supporting the weight of the wheel, particularly for larger diameter wheels. Do not allow the weight of the shaft to be supported by one bearing as you disassemble.
- Remove the wheel through the discharge or outlet area of the blower housing.
- Reassemble in reverse order, centering the wheel between the edges of the inlet venturi. If bearings were removed or replaced, be sure to reuse any shim stock found between the mounting support/plate and bearing housings.
- Torque all hardware.



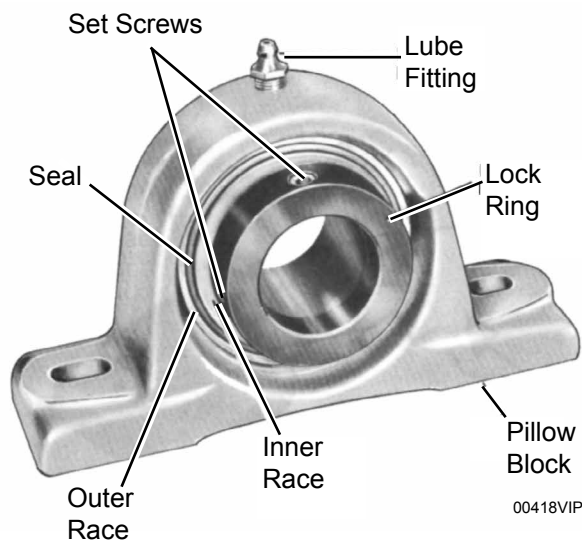
**Disconnect and lock-out power from the unit anytime service is being performed on the fan section. Failure to do so could result in serious injury or death due to the fan turning ON while work is in progress.**

## Fan Motor

1. Shut off unit power and lock out.
2. Disconnect and tag power wires at motor terminals.
3. Loosen motor base-to-mounting-rail attaching bolts.
4. Mark belt as to position. Remove and set aside belts.
5. Remove motor bracket hold down bolts.
6. Remove motor pulley and set aside.
7. Remove motor.
8. Install new motor. Reassemble by reversing steps 1 - 6. Be sure to reinstall multiple belts in their original position. Use a complete new set if required. Do not stretch belts over sheaves. Review the sections on motor and sheave installation, sheave alignment, and belt tensioning discussed previously.
9. Reconnect motor leads and restore power. Check fan for proper rotation as described in Start-Up Check List.

## Fan Shaft Bearings

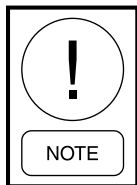
**General** – When removing and replacing the bearings, care should be taken to ensure that the area where the bearings fit on the shaft does not become scored or damaged. The shaft in this area should be thoroughly cleaned before the bearing is removed and again before the new bearing is installed.



**FIGURE 29 - BEARING WITH SETSCREW TYPE LOCKING DEVICE**

### Mounting Details

1. Check the shaft - it should be straight, free of burrs and full size. Be sure the bearing is not seated on a worn section of shafting.
2. Make certain any set screws are not obstructing the bearing bore.
3. Align the bearing in its housing and slide the bearing into position on shaft - never hammer the ends of the inner race. If necessary, use a brass bar or pipe against the inner race to drift bearing into place - never hit the housing, as bearing damage may result. Make sure there is lubricant between the bearing outer ring and the housing.
4. Fasten the bearing housing to the unit mounting support with hex head cap screws, washers, new lock washers and hex nuts before securing the bearing to the shaft. This permits the bearing to align itself in position along the shaft and eliminates any possibility of cramping loads.
5. Rotate the shaft to make certain it turns freely.
6. Bearings may employ one of several different methods to lock the bearing to the shaft.



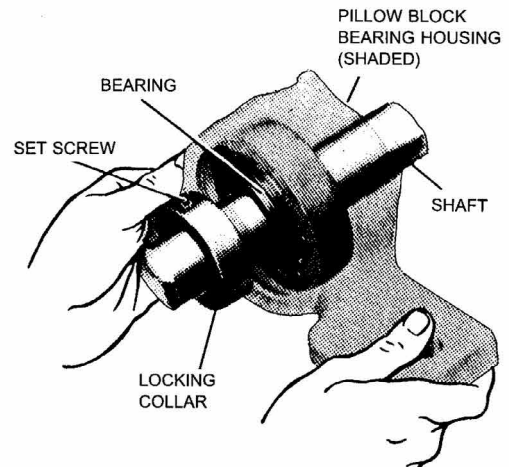
**Shaft should be free from burrs. If old shaft is used, be sure a ball bearing is not seated on worn section and shaft is not bent.**

There are various degrees of self-alignment in bearings of the same manufacturer. The force required for the self-alignment of the bearings used in Johnson Controls manufactured units has been specified and is closely monitored at the factory. If it is necessary to purchase a bearing locally, be sure it can be worked around in the housing with a short shaft made of wood or other soft material placed in the bearing.

Prior to installing the bearing on the shaft, it should be worked around in the housing to make sure that self-alignment will be obtained where the bearing is installed. After the shaft journal has been inspected for cleanliness, metal chips or burrs, the bearing is slipped, not forced, onto the shaft. Forcing the bearing onto the shaft by the use of flange, pillow block, or outer ring will damage the bearing internally. Force applied in this way transmits the load to the inner race through the balls in the bearing. Since the bearings are not designed for axial loading, the sides of the races in which the balls turn can be damaged. If the bearing cannot

be made to slip onto the shaft by pressing on the inner ring of the bearing, check the shaft for burrs. Install the bearing so the part of the inner race, which receives the locking collar or contains setscrews, is toward the outside of the unit.

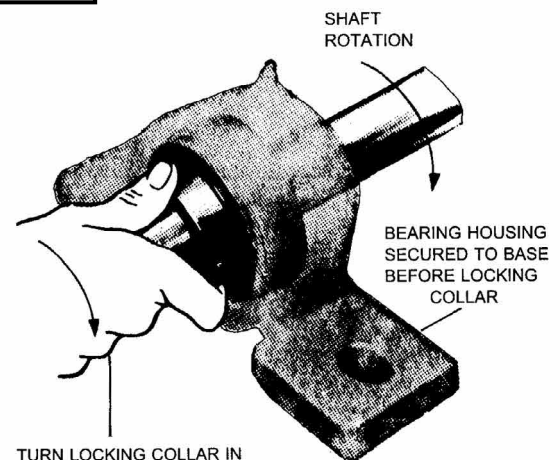
If the grease fitting must be changed on bearings that utilize a locking pin under the fitting, it is important to properly replace it. If an adapter or grease fitting of improper size and length is used, the locking pin may be either too tight or loose and can affect the alignment and re-lubrication of the bearing.



NOTE: Do Not apply excessive force to the bearing housing (pillow block or flange) when installing the bearing on the shaft.



**Do not apply excessive force to the bearing housing (pillow block or flange) when installing the bearing on the shaft.**



LD06358

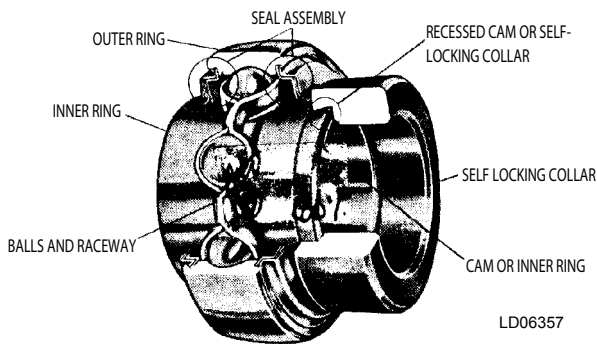
**FIGURE 30 - ECCENTRIC CAM LOCKING COLLAR BEARING INSTALLATION**

### Bearing Lock Devices

Various types of locking devices are used to secure bearing(s) to the fan shaft. Refer to the instructions packed with bearings for special information. *Figure 29 on page 70* is a typical bearing with a setscrew-type locking device. The various locking devices can be classified under basic types: eccentric locking type, concentric locking type, and Skwezloc type.

#### Eccentric Type

An eccentric self-locking collar is turned and driven with a punch in the direction of shaft rotation to lock the bearing inner ring to the shaft. *See Figure 31 on page 72.*



**FIGURE 31 - BEARING WITH ECCENTRIC CAM**

When the eccentric collar is engaged to the cam on the bearing inner ring and turned in direction of rotation, it grips the shaft with a positive binding action. The collar is then locked in place with the setscrew provided in the collar.

The self-locking collar is placed on the shaft with its cam adjacent to the cam on the end of the bearing's wide inner ring. In this position, with collar and bearing cams disengaged, the collar's bore is concentric with that of the bearing's inner ring. The wide inner ring is loose on the shaft. By turning the collar in the direction of normal shaft rotation, the eccentric recessed cam will drop over and engage with the corresponding cam on the bearing inner, causing it to grip the shaft tightly with a positive binding action. *See Figure 30 on page 71.* Make sure the two cams engage smoothly and the locking collar is down flat against the shoulder of the inner ring. The wide inner ring is now locked to the shaft. Using a punch or similar tool in the drilled hole of the collar, tap the tool lightly to lock the collar in the direction of normal shaft rotation.

As a final step, the setscrew is tightened. Torque per *Table 28 on page 72.* It exerts a wedging action to hold the collar always in the engaged position, even under shock and reversing loads.

To disassemble, loosen the setscrew and tap the collar in the direction opposite shaft rotation.

**TABLE 28 - SET SCREW TORQUE**

SET SCREW DIA.	HEX. SIZE ACROSS FLATS LBS.	MIN. RECOMMENDED TORQUE	
		INCH LBS.	FOOT LBS.
1/4 1/8	66 - 85	5.5 - 7.2	
5/16	5/32	126 - 164	10.5 - 13.7
3/8 3/16	228 - 296	19.0 - 24.7	
7/16	7/32	348 - 452	29.0 - 37.7
1/2 1/4	504 - 655	42.0 - 54.6	
5/8 5/16	1104 - 1435	92.0 - 119.6	

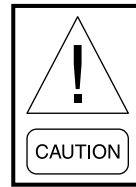


### Torquing of Set-screws

- Torque screw “A” to 1/2 recommended torque.
- Torque screw “B” to full min. recommended value.
- Torque screw “A” to full recommended value.



**FIGURE 32 - SPLIT BEARING**



*After proper installation of the bearing(s), run the unit for 10 to 15 minutes. Shut the unit down and lock it out. Check for proper engagement of locking collar and tightness of set screw(s).*

When replacing split bearings, refer to manufacturer’s instructions provided with the bearing. It is extremely important to ensure that proper radial clearances are observed between the roller bearings and outer face. Failure to make proper adjustments will cause premature failure of the bearing.

THIS PAGE INTENTIONALLY LEFT BLANK

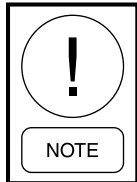
## SECTION 5 – SEQUENCE OF OPERATION

### UNIT TYPE

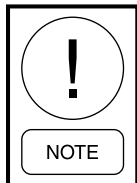
The Series 100 unit is capable of operating as three different unit types. The “UNIT TYPE” can be viewed/selected through the OPTIONS key, UNIT DATA subsection of the User Interface.

1. Constant Volume (CV) \*See note below  
Single Zone VAV (SZVAV)
2. Variable Air Volume (VAV)
3. Flexsys

\*As of 1/1/2016, the Series 100 units cannot be ordered configured for CV operation. All programming functions are still applicable.



*To see a complete list of the Options, Programs, and Setpoints menus, as well as min/max values and factory defaults, please refer to SECTION 6 – USER INTERFACE CONTROL CENTER of this manual.*



*Please refer to SECTION 8 – SERVICE of this manual for a list of acronyms and abbreviations.*

### OCCUPANCY/UNOCCUPANCY DETERMINATION

The Current Operating mode, OCC or UNOCC, is determined in one of three ways. The three ways are listed below in order of priority:

1. Hardwired: a 24 VAC input is provided to CTB1 at terminal OCC. Please note that the 24 VAC MUST be provided by the Series 100 unit.
2. Internal Time Clock: The unit is programmed for OCC/UNOCC times using the Internal Time Clock.
3. BAS Command: A BAS provides an OCC/UNOCC signal to the Series 100 unit.

### CURRENT OPERATING MODE

Within the Current Operating mode, the unit can operate in many different sub-modes. These sub-modes are listed below:

- “OCC STANDBY”
- “OCC COOLING” (VAV)
- “OCC COOLING LOW” (CV or SZVAV)
- “OCC COOLING HIGH” (CV or SZVAV)
- “OCC COOLING W/ BYPASS” (Flexsys)
- “OCC COOLING W/O BYPASS” (Flexsys)
- “OCC HEATING” (VAV/Flexsys)
- “OCC HEATING LOW” (CV or SZVAV)
- “OCC HEATING HIGH” (CV or SZVAV)
- “UNOCC COOLING” (VAV)
- “UNOC COOLING LOW” (CV or SZVAV)
- “UNOC COOLING HIGH” (CV or SZVAV)
- “UNOCCUPIED HEATING” (VAV/Flexsys)
- “UNOC HEATING LOW” (CV or SZVAV)
- “UNOC HEATING HIGH” (CV or SZVAV)
- “UNOCC STANDBY”
- “COMFORT VENT COOLING” (CV or SZVAV)
- “COMFORT VENT HEATING” (CV or SZVAV)
- “MORNING WARM-UP”
- “UNDER FLOOR TEMP OVERRIDE” (Flexsys)

The Current Operating mode can be viewed in the STATUS menu. The Unit Controller (IPU) monitors switching from a Standby mode to an Active Cooling/Heating mode. The unit must be in Standby mode for 3 minutes before switching to an Active Cooling/Heating mode.

### Constant Volume Mode

A “CONSTANT VOLUME” unit will be controlled by one of three “CONTROL METHODS.”

- “STAGED” (Thermostat wired into CTB1 or BAS Commands)
- “WIRED ZONE TEMP” (Hardwired sensor to CTB1)
- “COMM ZONE TEMP” (Zone temperature signal from a BAS)

The “CONTROL METHOD” is selected through the OPTIONS key under the UNIT DATA subsection.

**Staged Input**

- The Series 100 unit can be controlled by a standard 2 stage cooling/heating thermostat.
- The 24 VAC to the thermostat MUST be provided by the Series 100 unit
- Thermostat connections will be the standard connections: G, Y1, Y2, W1, W2.
- Thermostat commands can also be provided by a BAS.

**Zone Temperature Control**

- The Series 100 unit can be controlled by a zone temp sensor (10K Type III thermistor)
- Zone temp sensor can either be Hardwired to CTB1 or communicated from a BAS
- Hardwired: *"CONTROL METHOD"* set to *"WIRED ZONE TEMP"*
- Communicated from BAS: *"CONTROL METHOD"* set to *"COMM ZONE TEMP"*
- If Zone Temperature Control is selected but no zone temperature is provided or the wrong type is selected, the unit will display a Sensor/Misc fault and will LOCKOUT.

The following values must be set for Zone Temperature Control:

- *"OCC ZONE COOLING"* setpoint
- *"UNOCC ZONE COOLING"* setpoint
- *"OCC ZONE HEATING"* setpoint
- *"UNOCC ZONE HEATING"* setpoint

**Single Zone VAV (SZVAV)**

A *"SZVAV"* unit will be controlled by one of two *"CONTROL METHODS."*

- *"WIRED ZONE TEMP"* (Hardwired sensor to CTB1)
- *"COMM ZONE TEMP"* (Zone temperature signal from a BAS)

**Zone Temperature Control**

- The Series 100 unit can be controlled by a Zone Temp Sensor (10K Type III thermistor)
- Zone temp sensor can either be hardwired to CTB1 or communicated from a BAS

- Hardwired: *"CONTROL METHOD"* set to *"WIRED ZONE TEMP"*
- Communicated from BAS: *"CONTROL METHOD"* set to *"COMM ZONE TEMP"*
- If Zone Temperature Control is selected but no zone temperature is provided or the wrong type is selected, the unit will display a Sensor/Misc fault and will LOCKOUT

The following values must be set for Zone Temperature Control:

- *"OCC ZONE COOLING"* setpoint
- *"UNOCC ZONE COOLING"* setpoint
- *"OCC ZONE HEATING"* setpoint
- *"UNOCC ZONE HEATING"* setpoint

**Variable Air Volume (VAV)****Occupied**

- Supply fan is ON, controlled to *"DUCT STATIC PRESS"* setpoint
- Series 100 unit monitors RAT and compares it to *"RAT COOLING"* setpoint and *"RAT HEATING"* setpoint
- In VAV mode, the Series 100 unit can operate with no external control signals

**Unoccupied**

- Supply Fan is OFF
- Series 100 unit monitors the zone temperature and compares it the *"UNOCC ZONE COOLING"* and *"UNOCC ZONE HEATING"* setpoints
- *"NIGHT SET BACK"* MUST be enabled for Unocc Cooling/Heating to operate
- Unit MUST have a valid zone temperature. If there is not a valid zone temperature, the unit will display a Sens/Misc fault and will LOCKOUT.

**ACTIVE MODE DETERMINATION**

The Series 100 unit uses different methods to determine the active mode of operation. The different methods are listed below.

**Occupied Standby or Unoccupied Standby**

- There is no demand for cooling or heating based on the *"UNIT TYPE"* selected.
- Check the *"UNIT TYPE"* and see if a setpoint may need to be adjusted.

**Constant Volume**

**Staged**

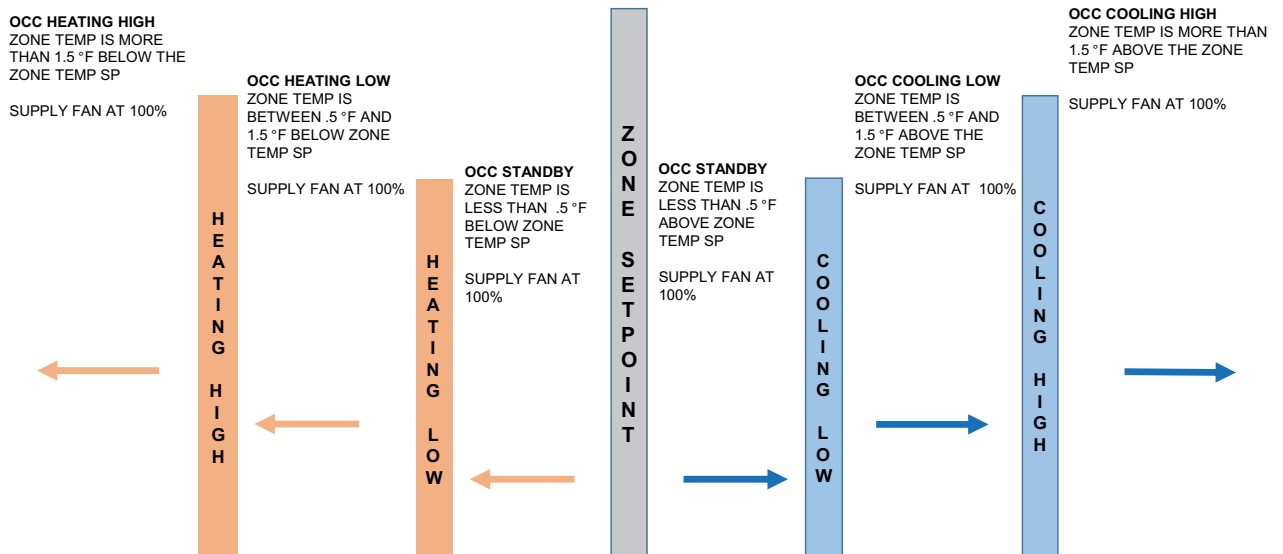
- 24 VAC input from a thermostat to CTB1
  - "OCC COOLING LOW": 24 VAC to Y1
  - "OCC COOLING HIGH": 24 VAC to Y2
  - "OCC HEATING LOW": 24 VAC to W1
  - "OCC HEATING HIGH": 24 VAC to W2
- Thermostat commands can also be given from a BAS
- Occupancy is determined by 24 VAC to CTB1 terminal OCC, Internal Time Clock, or Occupancy Command from BAS
- UNOCC modes are determined the same way as OCC modes

**Zone Sensor**

- Either hardwired to CTB1 or communicated from a BAS
  - "OCC COOLING LOW": 0.5 °F above "OCC ZONE COOLING" setpoint
  - "OCC COOLING HIGH": 1.5 °F above setpoint
  - "OCC HEATING LOW": 0.5 °F below "OCC ZONE HEATING" setpoint
  - "OCC HEATING HIGH": 1.5 °F below setpoint
- Occupancy determined same as staged above
- UNOCC modes are determined the same as OCC modes

**TABLE 29 - CV: OPERATIONAL MODE (STAGED INPUT)**

Y1 LOW COOL	Y2 HIGH COOL	W1 LOW HEAT	W2 HIGH HEAT	CURRENT OPER MODE	UNIT MODE
On	Off	Off	Off	Occupied	Occupied Cooling Low
On/Off	On	Off	Off	Occupied	Occupied Cooling High
Off	Off	On	Off	Occupied	Occupied Heating Low
Off	Off	On/Off	On	Occupied	Occupied Heating High
Off	Off	Off	Off	Occupied	Occupied Standby (See Comfort Ventilation on page 111)
On	Off	Off	Off	Unoccupied	Unoccupied Cooling Low
On/Off	On	Off	Off	Unoccupied	Unoccupied Cooling High
Off	Off	On	Off	Unoccupied	Unoccupied Heating Low
Off	Off	On/Off	On	Unoccupied	Unoccupied Heating High
Off	Off	Off	Off	Unoccupied	Unoccupied Standby



- NOTES:
- 1- WHENEVER THE UNIT ENTERS AN ACTIVE COOLING OR HEATING MODE, THE UNIT CONTROLLER WILL UTILIZE AS MANY OR AS FEW STAGES OF COOLING or HEATING THAT IT NEEDS TO ACHIEVE AND MAINTAIN THE ACTIVE SUPPLY AIR TEMP SP.
  - 2- UNOCCUPIED SEQUENCE WILL BE THE SAME AS ABOVE EXCEPT THE ZONE TEMP SPs USED WILL BE THE UNOCC SPs VALUES.
  - 3- UNIT MODES WILL STAGE DOWN WHEN THE ZONE TEMP IS .5 °F UNDER SPs FOR COOLING AND .5 °F OVER SPs FOR HEATING.

LD010572

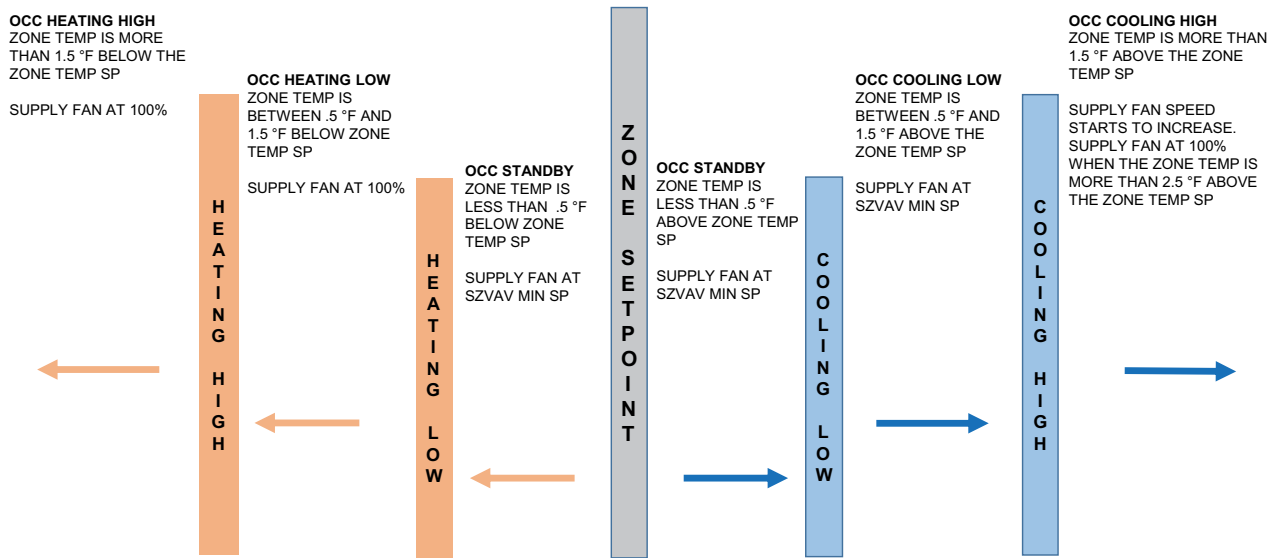
**FIGURE 33 - OPERATIONAL MODE (SPACE SENSOR INPUT)**

## Single Zone VAV

### Zone Sensor

- Either hardwired to CTB1 or communicated from a BAS
  - *"OCC COOLING LOW"*: 0.5 °F above *"OCC ZONE COOLING"* setpoint
  - *"OCC COOLING HIGH"*: 1.5 °F above setpoint

- *"OCC HEATING LOW"*: 0.5 °F below *"OCC ZONE HEATING"* setpoint
- *"OCC HEATING HIGH"*: 1.5 °F below setpoint
- Occupancy determined same as staged above
- UNOCC modes are determined the same as OCC modes



**NOTES:**

1- WHENEVER THE UNIT ENTERS AN ACTIVE COOLING OR HEATING MODE, THE UNIT CONTROLLER WILL UTILIZE AS MANY OR AS FEW STAGES OF COOLING or HEATING THAT IT NEEDS TO ACHIEVE AND MAINTAIN THE ACTIVE SUPPLY AIR TEMP SP.

2- UNOCCUPIED SEQUENCE WILL BE THE SAME AS ABOVE EXCEPT THE ZONE TEMP SPs USED WILL BE THE UNOCC SPs VALUES.

3- UNIT MODES WILL STAGE DOWN WHEN THE ZONE TEMP IS .5 °F UNDER SPs FOR COOLING AND .5 °F OVER SPs FOR HEATING.

LD19888

**FIGURE 34 - OPERATIONAL MODE: SINGLE ZONE VAV**

### Variable Air Volume

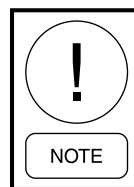
In the OCC mode, the Active mode will be determined by the Current RAT.

- *"OCC STANDBY"*: RAT is between the *"RAT COOLING"* and *"RAT HEATING"* setpoints
- *"OCC COOLING"*: RAT is greater than the *"RAT COOLING"* setpoint by 0.5 °F
- *"OCC HEATING"*: RAT is less than the *"RAT HEATING"* setpoint by 0.5 °F

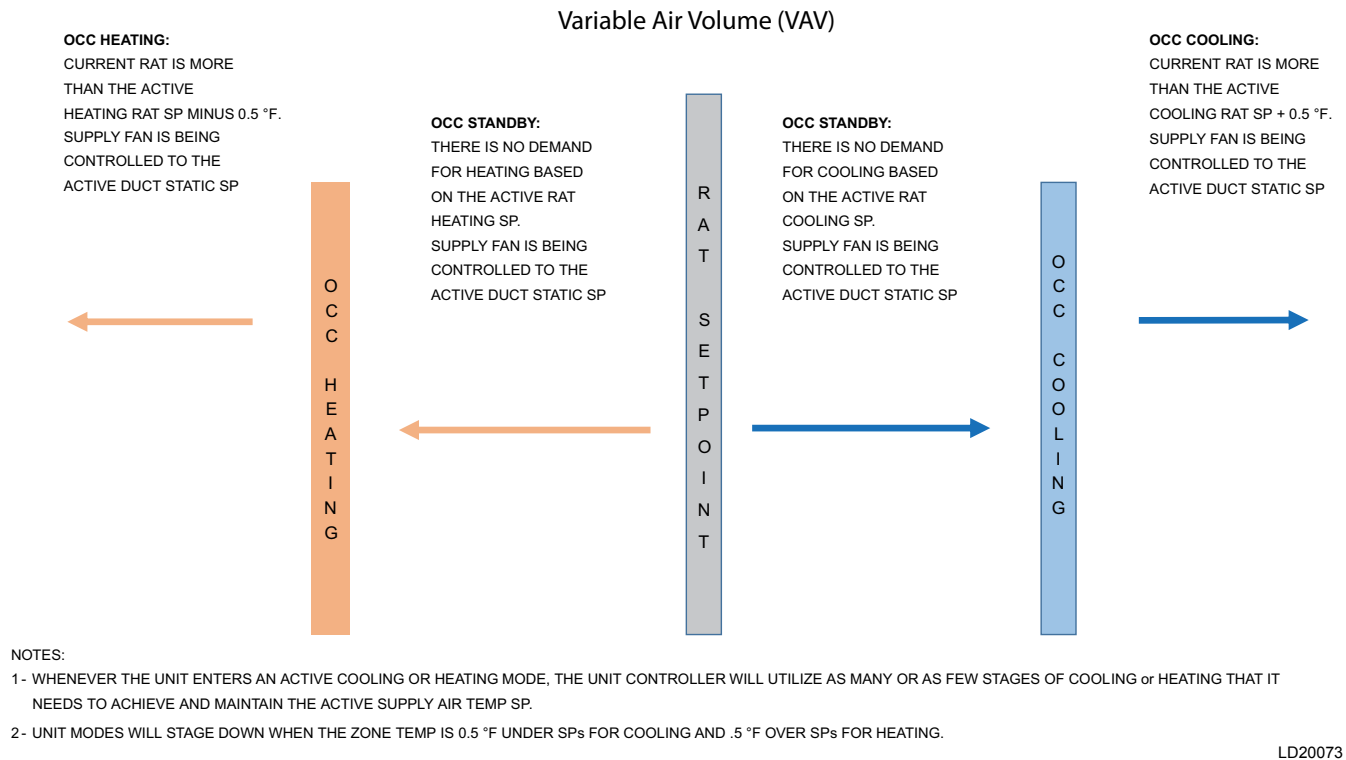
In the UNOCC mode, the Active mode will be determined by the zone temperature

- *"UNOCC STANDBY"*: Zone temperature is between the *"UNOCC ZONE COOLING"* and *"UNOCC ZONE HEATING"* setpoints

- *"UNOCC COOLING"*: Zone temperature is greater than the *"UNOCC ZONE COOLING"* setpoint by 0.5 °F
- *"UNOCC HEATING"*: Zone temperature is less than the *"UNOCC ZONE HEATING"* setpoint by 0.5 °F
- *"NIGHT SET BACK"* MUST be enabled for Unocc Cooling/Heating to operate
- Unit MUST have a valid zone temperature, or it shows a Sensor/Misc fault and will not operate



**The "RAT COOLING" setpoint and "RAT HEATING" setpoint cannot be closer than 2.0 °F, and the setpoints are not self adjusting. If the "RAT COOLING" setpoint needs lowered, the "RAT HEATING" setpoint may need lowered first. If the "RAT HEATING" setpoint needs raised, the "RAT COOLING" setpoint may need raised first.**



**FIGURE 35 - OPERATIONAL MODE: VAV**

**SUPPLY FAN OPERATION**

The supply fan is an integral part of the Series 100 unit. The supply fan **MUST** be on, and the supply fan proving circuit **MUST** be closed before any other unit operation is allowed.

**Supply Fan Proving Circuit**

- Same circuit for all unit types
- An air pressure switch closes when the supply fan starts and builds up enough pressure
- Once the supply fan output switches to ON, the air proving switch must be closed within 45 seconds
- If Supply Fan Proving Circuit is not made, unit will LOCKOUT
- If the Supply Fan Proving Circuit opens at any time during normal operation, the unit will LOCKOUT

**Constant Volume**

- No VFD
- Supply fan will start with 24 VAC input to “G” terminal on CTB1
- Supply fan will start with BAS command to FAN (G) point

- Supply fan will cycle ON with a 24 VAC input or BAS command to Y1, Y2, W1, or W2. When the 24 VAC input or BAS command is removed, supply fan will cycle OFF
- Supply fan will cycle ON when a zone temperature input (hardwired or BAS) energizes heating or cooling. Supply fan will cycle OFF when zone temperature input de-energizes heating or cooling
- Supply fan will run continuously in the OCC mode when "CONTINUOUS VENT" is enabled
- Supply fan will start when the unit is in "MORNING WARM UP"

**Single Zone VAV**

- Unit will have a factory installed and programmed VFD
- Supply fan will start with a demand for OCC or UNOCC cooling or heating
- Supply fan will run whenever the unit is in OCC if Continuous Ventilation is USER ENABLED
- Supply fan will start when the unit is in "MORNING WARM UP"

- Supply fan speed will be determined by the Unit mode
  - "OCC STANDBY": No demand for cooling or heating. Supply fan at "SZVAV MIN SPEED" setpoint.
  - "OCC COOLING LOW": Current Zone Temperature is more than 0.5 °F higher than the "ZONE TEMP" setpoint. Supply fan VFD at "SZVAV MIN SPEED" setpoint.
  - "OCC COOLING HIGH": Current Zone Temperature is more than 1.5 °F higher than

the "ZONE TEMP" setpoint. Supply fan VFD starts to speed up according to current Zone Temperature. Supply fan VFD will be at 100% when current Zone Temperature is 2.5°F above "ZONE TEMP" setpoint.

- "OCC HEATING LOW" and "OCC HEATING HIGH": Supply fan will be at 100%
- UNOCC modes are the same as the above OCC modes
- SZVAV Min Speed is user adjustable

TABLE 30 - SUPPLY FAN VFD SPEED DETERMINATION

$\Delta T_{OCC COOL}$	$\Delta T_{OCC HEAT}$	$\Delta T_{UNOCC COOL}$	$\Delta T_{UNOCC HEAT}$	OCCUPANCY MODE	UNIT MODE	SUPPLY FAN VFD SPEED
> 0.5 °F	---	---	---	Occupied	Occupied Cooling Low	SZVAV Min Speed
> 1.5 °F	---	---	---	Occupied	Occupied Cooling High	SZVAV Min Speed
> 2.5 °F	---	---	---	Occupied	Occupied Cooling High	100%
---	< -0.5 °F	---	---	Occupied	Occupied Heating Low	100%
---	< -1.5 °F	---	---	Occupied	Occupied Heating High	100%
---	---	---	---	Occupied	Occupied Standby (See <i>Comfort Ventilation on page 111</i> )	SZVAV Min Speed
---	---	> 0.5 °F	---	Unoccupied	Unoccupied Cooling Low	SZVAV Min Speed
---	---	> 1.5 °F	---	Unoccupied	Unoccupied Cooling High	SZVAV Min Speed
---	---	> 2.5 °F	---	Unoccupied	Unoccupied Cooling High	100%
---	---	---	< -0.5 °F	Unoccupied	Unoccupied Heating Low	100%
---	---	---	< -1.5 °F	Unoccupied	Unoccupied Heating High	100%
---	---	---	---	Unoccupied	Unoccupied Standby	Off

### Variable Air Volume

- Unit will have a factory installed and programmed VFD
- Supply fan will operate continuously when in OCC mode
- Supply fan will start when the unit is in either "UNOCC COOLING" or "UNOCC HEATING"
- Supply fan VFD will control the supply fan to maintain the "ACTIVE DUCT STATIC PRESSURE" setpoint
- Must set "DUCT STATIC RESET LOW" setpoint and "DUCT STATIC RESET HIGH" setpoint: SETPOINTS key / SUPPLY SYSTEMS subsection
- "DUCT STATIC OVERPRESSURE" setpoint: Factory default is 3.00 "W.C.

### Supply Fan Control

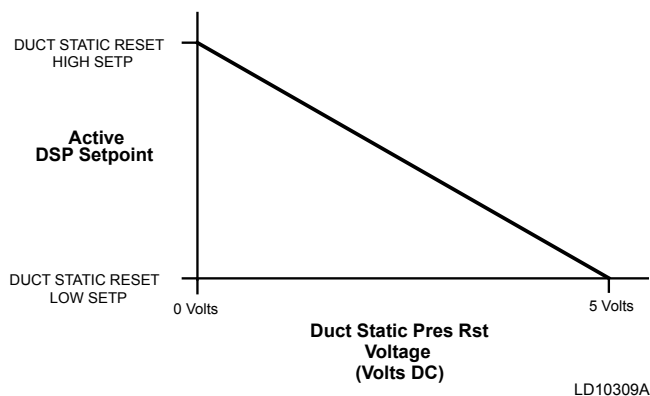
Once the supply fan is running, the speed will be controlled to the "ACTIVE DUCT STATIC PRESSURE" setpoint. The duct static transducer will monitor the duct static pressure and send a 0–5 VDC signal to the Unit Controller. The Unit Controller then compares the current duct static pressure to the "ACTIVE DUCT STATIC PRESSURE" setpoint. The Unit Controller will send a 0–10 VDC to the supply fan VFD to control the speed accordingly.

### Duct Static Pressure Reset

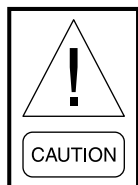
- The Series 100 unit can reset the "ACTIVE DUCT STATIC PRESSURE" setpoint by utilizing the "DUCT STATIC RESET SCHEDULE"
- If one constant static pressure is required, set both "DUCT STATIC RESET LOW" and "DUCT STATIC RESET HIGH" setpoints at same value



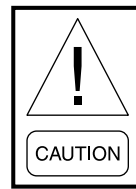
- A 0–5 VDC signal to CTB1 or a 0–100 (%) command from BAS will reset the "ACTIVE DUCT STATIC PRESSURE" setpoint
- 0 VDC or a 0 (%) BAS command will utilize the "DUCT STATIC RESET HIGH" setpoint
- 5 VDC or a 100 (%) BAS command will utilize the "DUCT STATIC RESET LOW" setpoint
- A VDC in between 0–5 VDC or a BAS command between 0–100 (%) will reset "ACTIVE DUCT STATIC PRESSURE" setpoint somewhere between the "DUCT STATIC RESET LOW" and "DUCT STATIC RESET HIGH" setpoints
- When using the BAS commands, the percent of reset will be from the High setpoint (0%) down to the Low setpoint (100%). Example: High setpoint of 2.00 "W.C. and Low setpoint of 1.00 "W.C. A 25% command will reset the "ACTIVE DUCT STATIC PRESSURE" setpoint to 1.75 "W.C. A command of 75% would reset the "ACTIVE DUCT STATIC PRESSURE" setpoint to 1.25 "W.C.
- "DUCT PRES RST BAS" must be enabled in SERVICE key to utilize reset from BAS



**FIGURE 36 - ACTIVE DSP SETPOINT VS. DUCT STATIC PRES RST VOLTAGE**



*The bypass VFD is a standard Variable Frequency Drive packaged with an additional set of contactors. When bypass mode is activated, contactors route power around the VFD, connecting the indoor fan motor directly to the supply voltage. At this point, the motor will go to full RPM regardless of the duct pressure signal, because the VFD is out of the loop, and there is a potential for over pressuring the ducts.*



*The air balancer must set maximum duct static / CFM to stay within a static pressure that the ductwork of that installation can tolerate when the motor is at full RPM, considering that the VAV boxes, if they are part of the system, may not be full open.*

*If the duct system includes VAV boxes, they must be driven open in Bypass mode. Failure to do so could result in damage to the ductwork and the building structure.*

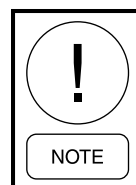
### Supply Fan Sync

The Series 100 units are capable of using a 0–5 VDC signal to control the supply fan VFD speed. This allows units that are connected in a master/satellite type configuration, also known as twinning, to maintain the same fan speed.

The 0–5 VDC signal must be provided to the below terminals on CTB1:

- 25: +5 V ("DUCT STATIC" setpoint +5 V)
- 26: DSP+ ("DUCT STATIC RESET" +)
- 27: DSP- ("DUCT STATIC RESET" -)

We do not allow a BAS command to control the supply fan VFD speed due to slow response time and possible over-pressurization of the duct system.



*We recommend installing the tubing from the duct pressure transducer to the proper location in the unit ductwork. The duct pressure transducer provides the only factory installed duct over pressure device.*

### Sequence of Operation

- "UNIT TYPE" must be configured for "VARIABLE AIR VOLUME"
- Supply Fan Sync must be set to USER ENABLED
- The unit must be receiving a 0–5 VDC signal at CTB1 terminals 26 and 27
- The Unit Controller requires approximately 1 VDC to start the supply fan VFD. Once the fan is started, the below chart lists the expected speeds and speed % at different VDC inputs.
- If the VDC input drops to approximately 0.5 VDC, the fan will shut down

- 1 VDC to start supply fan VFD; 0.5 VDC to stop supply fan VFD
- 1 VDC: 20% at approximately 32 hz
- 2VDC: 40% at approximately 40 hz
- 3 VDC: 60% at approximately 46 hz
- 4 VDC: 80% at approximately 53 hz
- 5 VDC: 100% at approximately 60 hz

### ACTIVE SUPPLY AIR TEMPERATURE SETPOINTS

Depending on the "UNIT TYPE" that is selected, the Series 100 units will use different setpoints for the Supply Air Temperature (SAT).

Once a Series 100 unit enters an Active Cooling or Heating mode, it will utilize as many or as few stages of cooling or heating as needed to achieve and maintain the "ACTIVE SAT" setpoint. Since the Series 100 unit utilizes DX (direct expansion) cooling, there is logic and algorithms built into the program to prevent short-cycling of compressors and/or stages of heat. There will be some under and over shooting of

the "ACTIVE SAT" setpoint. This under/over shooting should normally stay within +/- 3 °F. There could be some infrequent times where this under/over shoot approaches +/- 5 °F.

### Constant Volume: Staged (Thermostat or a BAS Command)

#### Occupied/Unoccupied

- 1st Stage Cooling setpoint:
  - 24 VAC input to Y1
  - BAS command to Y1
- 2nd Stage Cooling setpoint:
  - 24 VAC input to Y2
  - BAS command to Y2
- 1st Stage Heating setpoint:
  - 24 VAC input to W1
  - BAS command to W1
- 2nd Stage Heating setpoint:
  - 24 VAC input to W2
  - BAS command to W2

**TABLE 31 - ACTIVE SAT SETPOINT DETERMINATION, STAGED INPUT**

Y1 LOW COOL	Y2 HIGH COOL	W1 LOW HEAT	W2 HIGH HEAT	OCC. MODE	UNIT MODE	ACTIVE SP
On	Off	Off	Off	Occupied	Occupied Cooling Low	1st stage cooling setpoint
On/Off	On	Off	Off	Occupied	Occupied Cooling High	2nd stage cooling setpoint
Off	Off	On	Off	Occupied	Occupied Heating Low	1st stage heating setpoint
Off	Off	On/Off	On	Occupied	Occupied Heating High	2nd stage heating setpoint
Off	Off	Off	Off	Occupied	Occupied Standby (See <i>Comfort Ventilation on page 111</i> )	None
On	Off	Off	Off	Unoccupied	Unoccupied Cooling Low	1st stage cooling setpoint
On/Off	On	Off	Off	Unoccupied	Unoccupied Cooling High	2nd stage cooling setpoint
Off	Off	On	Off	Unoccupied	Unoccupied Heating Low	1st stage heating setpoint
Off	Off	On/Off	On	Unoccupied	Unoccupied Heating High	2nd stage heating setpoint
Off	Off	Off	Off	Unoccupied	Unoccupied Standby	None

### Constant Volume: Zone Temperature Sensor (Hardwired or Communicated from a BAS)

#### Occupied

- 1st Stage Cooling setpoint:
  - Zone Temperature is 0.5 °F higher than the "OCC ZONE COOLING" setpoint

- 2nd Stage Cooling setpoint:
  - Zone Temperature is 1.5 °F higher than the "OCC ZONE COOLING" setpoint
- 1st Stage Heating setpoint:
  - Zone Temperature is 0.5 °F lower than the "OCC ZONE HEATING" setpoint

- 2nd Stage Heating setpoint:
  - Zone Temperature is 1.5 °F lower than the "OCC ZONE HEATING" setpoint

**Unoccupied**

- 1st Stage Cooling setpoint:
  - Zone Temperature is 0.5 °F higher than the "UNOCC ZONE COOLING" setpoint
- 2nd Stage Cooling setpoint
  - Zone Temperature is 1.5 °F higher than the "UNOCC ZONE COOLING" setpoint

- 1st Stage Heating setpoint:
  - Zone Temperature is 0.5 °F lower than the "UNOCC ZONE HEATING" setpoint
- 2nd Stage Heating setpoint:
  - Zone Temperature is 1.5 °F lower than the "UNOCC ZONE HEATING" setpoint

CV operation has no reset schedule for the first and second stage cooling and heating setpoints built into the Series 100 unit's program, but all four setpoints are available through a BAS and are R/W.

**TABLE 32 - ACTIVE SAT SETPOINT DETERMINATION, ZONE TEMPERATURE**

$\Delta T_{OCC\ COOL}$	$\Delta T_{OCC\ HEAT}$	$\Delta T_{UNOCC\ COOL}$	$\Delta T_{UNOCC\ HEAT}$	OCCUPANCY MODE	UNIT MODE	ACTIVE SP
> 0.5 °F	---	---	---	Occupied	Occupied Cooling Low	1st Stage Cooling Setpoint
> 1.5 °F	---	---	---	Occupied	Occupied Cooling High	2nd Stage Cooling Setpoint
---	< -0.5 °F	---	---	Occupied	Occupied Heating Low	1st Stage Heating Setpoint
---	< -1.5 °F	---	---	Occupied	Occupied Heating High	2nd Stage Heating Setpoint
---	---	---	---	Occupied	Occupied Standby (See <i>Comfort Ventilation on page 111</i> )	None
---	---	> 0.5 °F	---	Unoccupied	Unoccupied Cooling Low	1st Stage Cooling Setpoint
---	---	> 1.5 °F	---	Unoccupied	Unoccupied Cooling High	2nd Stage Cooling Setpoint
---	---	---	< -0.5 °F	Unoccupied	Unoccupied Heating Low	1st Stage Heating Setpoint
---	---	---	< -1.5 °F	Unoccupied	Unoccupied Heating High	2nd Stage Heating Setpoint
---	---	---	---	Unoccupied	Unoccupied Standby	None

**Single Zone VAV**

**Occupied**

- 1st Stage Cooling setpoint:
  - Zone Temperature is 0.5 °F higher than the "OCC ZONE COOLING" setpoint
- 2nd Stage Cooling setpoint
  - Zone Temperature is 1.5 °F higher than the "OCC ZONE COOLING" setpoint
- 1st Stage Heating setpoint:
  - Zone Temperature is 0.5 °F lower than the "OCC ZONE HEATING" setpoint
- 2nd Stage Heating setpoint:
  - Zone Temperature is 1.5 °F lower than the "OCC ZONE HEATING" setpoint

**Unoccupied**

- 1st Stage Cooling setpoint:
  - Zone Temperature is 0.5 °F higher than the "UNOCC ZONE COOLING" setpoint
- 2nd Stage Cooling setpoint
  - Zone Temperature is 1.5 °F higher than the "UNOCC ZONE COOLING" setpoint
- 1st Stage Heating setpoint:
  - Zone Temperature is 0.5 °F lower than the "UNOCC ZONE HEATING" setpoint
- 2nd Stage Heating setpoint:
  - Zone Temperature is 1.5 °F lower than the "UNOCC ZONE HEATING" setpoint

SZVAV operation has no reset schedule for the first and second stage cooling and heating setpoints built into the Series 100 unit's program, but all four setpoints are available through a BAS and are R/W. See *Table 32 on page 81*.

## Variable Air Volume

### Supply Air Temperature Reset

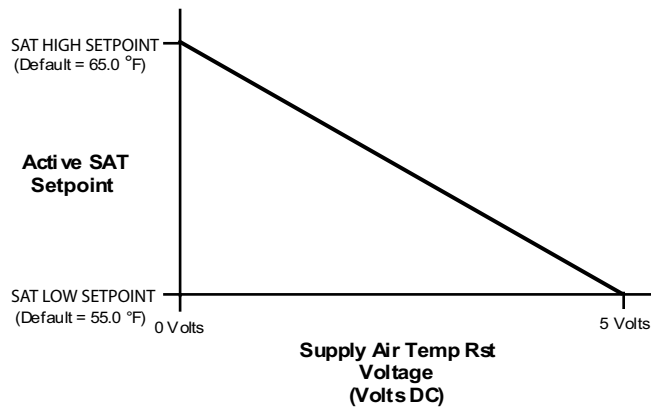
With a Series 100 unit set up for VAV operation, there is the ability to reset the "*ACTIVE SUPPLY AIR TEMP*" setpoint by one of four different methods. This is for the "*COOLING SAT*" setpoints only.

1. Hardwired
2. Outside Air
3. Return Air
4. Supply Fan VFD Speed

The "*ACTIVE SUPPLY AIR TEMP*" setpoint will be maintained at or between the "*SAT HIGH*" and "*SAT LOW*" setpoints depending on which "*SAT RESET METHOD*" is selected and the setpoints associated with that "*SAT RESET METHOD*."

#### Hardwired SAT Reset

- A 0–5 VDC signal wired into CTB1
- A 0–5 command from a BAS
- 0 VDC or a 0 command from the BAS: the unit will utilize the "*SAT HIGH*" setpoint
- 5 VDC or a 5 command from the BAS: the unit will utilize the "*SAT LOW*" setpoint
- A VDC or command from the BAS in between 0–5: the unit will maintain a setpoint somewhere between the "*SAT HIGH*" and the "*SAT LOW*" setpoints
- "*SAT RESET METHOD*" set to "*HARDWIRED*"
- "*SAT RST BAS*" must be enabled in the SERVICE key menus in order to communicate the 0–5 command

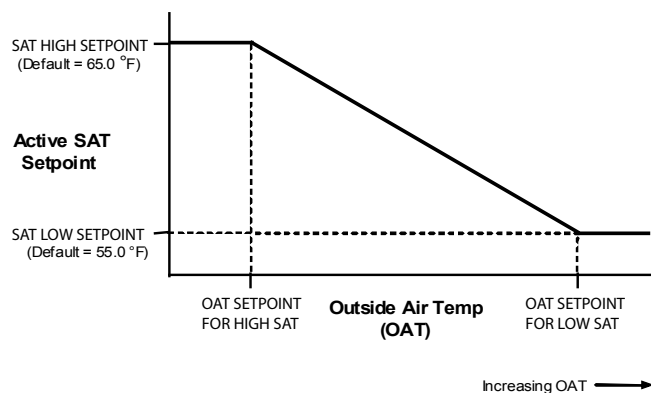


LD12587

**FIGURE 37 - ACTIVE SAT SETPOINT VS. SUPPLY AIR TEMP RST VOLTAGE**

#### Outside Air SAT Reset

- The Series 100 unit will reset the active "*COOLING SAT*" setpoint based on the Outside Air Temperature (OAT)
- Must set the "*OAT SETPOINT FOR HIGH SAT*" and "*OAT SETPOINT FOR LOW SAT*": SETPOINTS key / COOLING subsection
- "*SAT RESET METHOD*" set to "*OUTSIDE AIR*"
- OAT equal to or less than the "*OAT SETPOINT FOR HIGH SAT*": the unit will utilize the "*SAT HIGH*" setpoint
- OAT equal to or greater than the "*OAT SETPOINT FOR LOW SAT*": the unit will utilize the "*SAT LOW*" setpoint

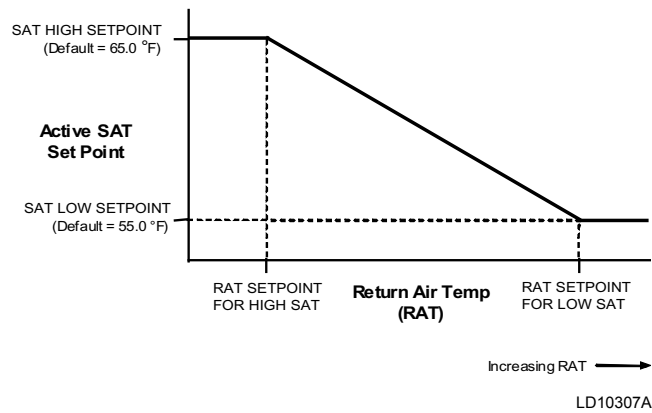


LD12588

**FIGURE 38 - ACTIVE SAT SETPOINT VS. OUTSIDE AIR TEMP**

### Return Air SAT Reset

- The Series 100 unit will reset the active "COOLING SAT" setpoint based on the Return Air Temperature (RAT)
- Must set the "RAT SETPOINT FOR HIGH SAT" and "RAT SETPOINT FOR LOW SAT": SETPOINTS key / COOLING subsection
- "SAT RESET METHOD" set to "RETURN AIR"
- RAT equal to or less than the "RAT SETPOINT FOR HIGH SAT": the unit will utilize the "SAT HIGH" setpoint
- RAT equal to or greater than the "RAT SETPOINT FOR LOW SAT": the unit will utilize the "SAT LOW" setpoint

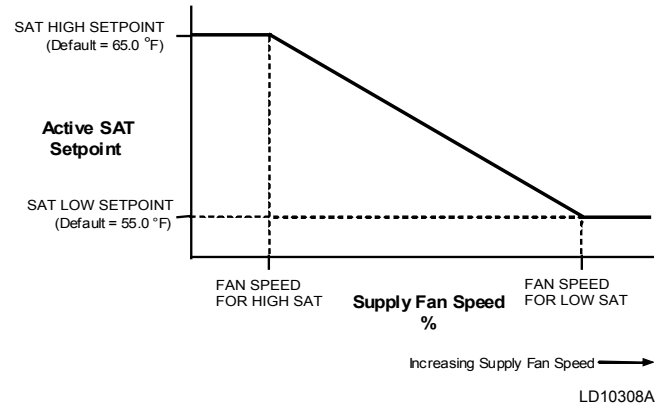


**FIGURE 39 - ACTIVE SAT SETPOINT VS. RETURN AIR TEMP**

### Supply Fan VFD Speed SAT Reset

- The Series 100 unit will reset the active "SAT COOLING" setpoint based on the Supply Fan VFD Speed
- Must set the "FAN SPEED SETPOINT FOR HIGH SAT" and "FAN SPEED SP FOR LOW SAT": SETPOINTS key / COOLING subsection
- "SAT RESET METHOD" set to "SUPPLY FAN SPEED"

- VFD speed equal to or less than the "FAN SPEED SETPOINT FOR HIGH SAT": the unit will utilize the "SAT HIGH" setpoint
- VFD speed equal to or greater than the "FAN SPEED SETPOINT FOR LOW SAT": the unit will utilize the "SAT LOW" setpoint



**FIGURE 40 - ACTIVE SAT SETPOINT VS. SUPPLY FAN SPEED**

These different setpoints can be set using the Series 100 unit's control panel or through a BAS.

The "SAT RESET METHOD" MUST be set using the unit's control panel.

The "SAT HIGH" setpoint and "SAT LOW" setpoint are R/W points, and a separate reset method could be utilized using programming in the BAS.

### Heating SAT Setpoint

- The "HEATING SAT" setpoint has no reset schedules available
- Must set the "HEATING SAT" setpoint: SETPOINTS key / HEATING subsection
- "HEATING SAT" setpoint is a R/W point through a BAS

**COMPRESSOR CONTROL**

Whenever a change in the unit cooling status is made:

- Compressor turned OFF, or
- Compressor turned ON,

a 3.5 minute Interstage Delay Timer is initiated. During these 3.5 minutes, no compressor can be started or stopped normally. A compressor will still be stopped immediately if a safety fault occurs.

**Compressor Control (CV, SZVAV, and VAV)**

1. Series 100 unit enters an Active Cooling mode
2. Unit Controller sets the “*COOLING CONTROL OFFSET*” to 2.0 °F
3. Unit Controller compares the SAT to the “*ACTIVE SAT*” setpoint plus or minus the “*COOLING CONTROL OFFSET*”
4. If SAT is greater than the “*ACTIVE SUPPLY AIR TEMP*” setpoint plus the “*COOLING CONTROL OFFSET*,” Unit Controller will:
  - a. Start a compressor

OR

  - b. Bring on an additional stage of cooling based on the “*NEXT STAGE TO ENABLE*”
5. If SAT is less than the “*ACTIVE SUPPLY AIR TEMP*” setpoint minus the “*COOLING CONTROL OFFSET*,” Unit Controller will:
  - a. Stop a compressor based on the “*NEXT STAGE TO DISABLE*”

**Compressor Operation with Economizer**

- When the OA conditions are suitable for economizer operation, the Unit Controller will set the “*COOLING CONTROL OFFSET*” to 4.5 °F
- The “*COOLING CONTROL OFFSET*” will remain at 4.5 °F as long as the OA conditions are suitable and the economizer remains active

Economizer becomes active and no compressors are operating:

1. Compressors will be started based on the “*NEXT STAGE TO ENABLE*” when ALL of the following are true:
  - a. Econ Control Output greater than 95% for 30 sec

- b. SAT greater than or equal to “*ACTIVE SUPPLY AIR TEMP*” setpoint plus the “*COOLING CONTROL OFFSET*” (4.5 °F)

- c. 3.5 min Interstage Delay Timer has expired

2. Compressors will be stopped based on the “*NEXT STAGE TO DISABLE*” when ALL the following are true:

- a. Econ Control Output less than 5% for 30 sec

- b. SAT less than or equal to the “*ACTIVE SUPPLY AIR TEMP*” setpoint minus the “*COOLING CONTROL OFFSET*” (4.5 °F)

- c. 3.5 min Interstage Delay Timer has expired

Economizer becomes active and one or more compressors operating:

1. A compressor will be staged OFF, and the sequence above will be utilized

**Compressor Staging**

The Series 100, 50-65 ton unit has two completely separate refrigeration circuits. There are two scroll compressors per circuit for a total of four scroll compressors.

**Fast Compressor Start**

The Series 100 Unit Controller will use an Optimum Stage-Up Algorithm to quickly bring on the correct numbers of compressors when changing from “*OCC/UNOCC STANDBY*” to “*OCC/UNOCC COOLING*.” This sequence is called Fast Compressor Start and will work for all unit configurations.

- USER ENABLED - Unit Controller will determine which stage is needed for the initial cooling demand and will start the appropriate compressors needed
- USER DISABLED - Unit Controller will bring on one compressor at a time with a 3.5-minute Interstage Delay Timer between each stage

**Compressor Staging Logic**

The compressor staging logic utilizes many different factors to determine the available compressors.

- Unit Size
- Compressor System Status (Normal or Faulted)

### Current Stage

1. Unit enters an Active Cooling mode
2. Unit Controller will determine the appropriate compressors to start based on the following:
  - a. Internal programming logic  
AND
  - b. Status of Fast Comp Start
    1. USER ENABLED
    2. USER DISABLED

### Economizer Available

1. Unit enters an Active Cooling mode and before any compressor is started, the “*CURRENT STAGE*” shall be set to 0
2. If “*ECON AVAILABLE*” is YES and the conditions determine that compressors are needed, Unit Controller will start the compressors that are needed for Stage 1 and set the “*CURRENT STAGE*” to 1
3. Staging up/down from this point will be in a sequential manner (Step 1, 2, 3, 2, 1 etc.)
4. “*CURRENT STAGE*” will be recorded each time the controller stages up/down

### Economizer Not Available and Fast Compressor Start Disabled

1. Unit enters an Active Cooling mode
2. Unit Controller will set the next stage to 1, and the compressors will be started/stopped sequentially
3. Four stages

### Economizer Not Available and Fast Compressor Start Enabled

1. Unit enters an Active Cooling mode
2. Unit Controller will determine the cooling stage needed for the initial cooling demand
3. Unit Controller will bring on the appropriate compressors needed for the initial cooling demand
4. There will be a 10 second delay between compressors starting for the initial cooling demand
5. Once all the appropriate compressors have been started for the initial cooling demand, the Unit Controller will:

- a. Wait 3.5 minutes
- b. Determine if more or less cooling is needed
- c. More Cooling: will start/stop the appropriate compressors for the next higher stage
- d. Less Cooling: will start/stop the appropriate compressors for the next lower stage

### Changing Staging Sequences

1. During an Active Cooling mode, certain conditions could cause the Unit Controller to change the current staging method
  - a. “*HOT GAS REHEAT*” becomes active/inactive
  - b. One or more compressor systems develop a Fault condition
  - c. Comp System Fault condition is cleared
  - d. Economizer goes active/inactive
2. When this occurs, the Unit Controller will determine the proper compressor stage for the conditions
3. When changing staging sequences, the Unit Controller will:
  - a. Temporarily stop the “*COOLING CONTROL OFFSET*” calculation
  - b. Hold the current “*COOLING CONTROL OFFSET*” value
  - c. Wait until the staging sequence has completed
  - d. Wait until 3.5 minutes has expired
  - e. Resume normal operation based on the new staging sequence

### COMPRESSOR STATUS AND RUN DATA

#### Compressor Run Data

- The Unit Controller will monitor the compressor starts and compressor run hours.
- This data will be stored under the OPERATING HOURS / START COUNTER key
- Operating hours/start counts cannot be reset

#### Compressor Status

- Each compressor circuit will have a high and low pressure switch

- Some compressors will have a compressor motor protector inside the compressor electrical box, and some will just utilize an internal thermal overload
  - 50 Ton Unit: All (four) compressors have internal thermal overloads; no motor protectors
  - 51 ton unit: All (four) compressors have internal thermal overloads; no motor protectors
  - 60 ton unit: Comp 1A and 2A have internal thermal overloads; 1B and 2B have motor protectors
  - 61 ton unit: Comp 1A has an internal thermal overload; 1B, 2A, and 2B have a motor protector
- The Unit Controller will monitor several different parameters to determine the status of a compressor circuit
  - *"HIGH DP UNLOAD"*
  - *"LOW AMB INHIBIT"*
  - *"LOW SUCT TEMP UNL"*
  - *"COMPR # SAFETY TRIP"*
  - *"COMPR # SAFETY FAULT"*
  - *"COMPR # SAFETY LOCKOUT"*
- If NONE of the above conditions exist, a compressor will be placed in a Ready to Run state
- Once a compressor is started, after the 3.5-minute Minimum On Timer has expired, the Unit Controller will change a compressor status to Ready to Stop state

### Compressor Safety Circuit

- The Unit Controller will monitor the Compressor Safety Circuit for each compressor system
- The Compressor Safety Circuit will include the following:
  - High pressure switch
  - Compressor solid state motor protector, if applicable
- The internal thermal overload is not connected to the compressor safety chain. If the internal thermal overload opens, the safety circuit will remain closed and no alarm will be generated.

- Each compressor circuit also has a low pressure switch and suction line temp sensor. They are NOT a component of the Compressor Safety Circuit but are still monitored and are part of determining a compressor's status. The Low Pressure Cutout (LPCO) will have its own separate fault.

### Compressor Safety Circuit: Safety Trips and Safety Lockouts

- The components in the Compressor Safety Circuit are wired in series
- When all safeties are closed, there will be a 24 VAC input to the I/O board
- If any of the components open while a compressor is operating, both compressors in that circuit will be stopped (the 24 VAC input will be lost)
- The Unit Controller then monitors the time it takes for the open safety to reset and close (24 VAC input will be re-established)
- The time to reset (re-establish 24 VAC input) will be recorded in the HISTORY buffer and identified as the *"COMP STATUS # CLEAR TIME"*
  - Compressor Solid State Motor Protector: typically 30 minutes to clear
  - High Pressure Switch: typically less than 1 minute
- If the reset time is greater than 60 minutes, *"COMP STATUS # CLEAR TIME"* will be changed to *"COMP STATUS # TIME OUT,"* and a *"COMP SYSTEM #- SAFETY LOCKOUT"* will be generated.

### Compressor System Safety Trip

- Safety circuit input is ignored when both the compressors of any system are OFF
- If either or both compressors are ON and the safety circuit opens, the Unit Controller will turn OFF the active compressors for that circuit
- Compressor system will be made active again when the safety circuit is closed
- If Compressor Safety Circuit opens, the following will occur:
  - A *"COMP SYS # STATUS – SAFETY TRIP"* will be stored in the HISTORY buffer
  - The first safety trip will display *"COMP # SAFETY TRIP 1"*



- A second trip within 120 minutes will display “*COMP # SAFETY TRIP 2*”
- A third trip within 120 minutes will cause the compressor system to LOCKOUT. HISTORY buffer will display “*COMP SYSTEM # – SAFETY LOCKOUT*”
- A manual reset will be required
- If 120 minutes expires before a second or third safety circuit trip, the Safety Circuit Timer will be reset.

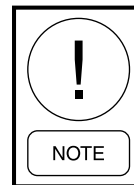
### Low Pressure Cutout

- Operation of the LPCO will be the same as the Compressor Safety Circuit except for:
  - The low pressure switch will be ignored during the first 45 seconds once a compressor system starts
- The low pressure switch will be ignored when a compressor system is inactive
- Safety trips and safety lockouts will follow the same logic as above
- HISTORY buffer displays:
  - “*COMP # LPCO TRIP 1 OR 2*”
  - “*COMP SYS # STATUS – SAFETY LOCKOUT*”

### Resetting a Compressor System Safety Lockout

- Once a compressor system experiences either a Compressor Safety Lockout or a Compressor LPCO Safety Lockout, a manual reset will be required
- Reset a Safety Lockout by performing the following steps:
  1. Leave the unit control/rocker switch ON
  2. Press the COMPRESSOR SYSTEMS key
  3. Use the ◀ or ▶ keys to navigate to the compressor system with the LOCKOUT
  4. Use the ▲ or ▼ keys to find the screen that displays *COMPRESSOR SYS # STATE – LOCKOUT*
  5. Press the PROGRAM key and, use the ◀ or ▶ keys to navigate until the top line of the display shows *PROGRAM – COMPRESSOR SYSTEM #*

6. Press the ✓ key and enter the password 9725, if prompted, and press the ✓ key again
7. The display should now show:
  - *PROGRAM – COMPRESSOR SYSTEM #      ✓ TO EDIT*
  - *COMPRESSOR SYS # STATE    LOCKOUT*
8. Press the ✓ key and use the ◀ or ▶ keys to change from LOCKOUT to RUN, and press the ✓ key again
  - If Compressor State returns to LOCKOUT, a safety switch is still open and further troubleshooting is required
9. If Compressor State remains in RUN, press the X key and exit out of the *PROGRAM – COMPRESSOR SYSTEM # MENU*
10. The Compressor System Lockout has now been cleared and reset



**The # symbol will be replaced by the compressor system # (e.g. 1, 2, or 3) on the actual display on the unit.**

### Suction Temperature Monitoring

- Whenever a compressor is operating, the Unit Controller will monitor the suction line temperature for the system
- Suction line temperature falls below suction low limit, 37 °F for R-410A, for 10 seconds the Unit Controller will:
  11. Display the following
    - a. STATUS screen: “*COMP SYS # STATUS – LOW SUCT TEMP UNLOAD*”
    - b. COMPRESSOR SYSTEMS screen: “*STATUS LOW SUCT TEMP UNL*”
    - c. HISTORY screen: “*LOW SUCT TEMP # TRIP*”
  12. If both compressors were operating, Unit Controller will turn OFF the compressor with the longest run time
  13. Unit Controller will start a 60-second timer
  14. After 60 seconds, the Unit Controller will monitor the suction line temperature for the operating compressor

15. If the suction line temperature falls below the suction low limit, 37 °F for R-410A, the other compressor will be turned OFF
- This fault will be cleared for each compressor when the suction line temperature is greater than the suction low limit, 37 °F for R-410A, plus 10 °F for 10 minutes.

### High Discharge Pressure Unloading

This feature allows the Unit Controller to shut down compressors before the discharge pressure reaches the *"HIGH PRESSURE CUT-OUT"* setpoint, thus providing reduced cooling for units that may have dirty condenser coils, overcharged systems, defective condenser fan motors, or the outside ambient temperature is higher than design conditions.

### Sequence of Operation

1. Unit **MUST** have discharge pressure transducers installed for this feature to operate
2. *"SYSTEM UNLOADING PRESSURE"* **MUST** be set in the SETPOINTS key / COMPRESSOR SYSTEMS subsection
3. Both compressors for a compressor system **MUST** be operating
4. System discharge pressure greater than/equal to the *"SYSTEM UNLOADING PRESSURE"* setpoint for 10 seconds
5. Unit Controller will turn OFF the compressor with the fewest number of starts.
6. Unit Controller will record the OAT at time of shutting down compressor
7. The *"HIGH DP UNLOAD"* will be cleared when:
  - a. The current OAT is less than the OAT at time of trip by at least 5.0 °F
  - AND
  - b. The discharge pressure is less than the *"SYSTEM UNLOADING PRESSURE"*

### Low Ambient Operation

- The Series 100, 50–65 ton units can operate mechanical cooling as low as 50.0 °F OAT with standard controls
- Mechanical cooling will be allowed to operate down to minimum 0 °F with a low ambient kit installed. *"MECH COOLING LOCKOUT"* temperature is user adjustable between 0–65 °F with a low ambient kit

- Series 100, 50–65 ton units only have the option for a low ambient kit on circuit 1
- A low ambient kit will include a discharge pressure transducer and a condenser fan VFD
- The condenser fan VFD will control the speed of condenser fan 1A to maintain proper refrigerant pressures
- The condenser fan VFD will start at 15 hz and will start to speed up at approximately 270 psig.
- Condenser fan VFD will be at 100% at approximately 350 psig

### HOT GAS REHEAT (SZVAV AND VAV ONLY)

The Series 100, 50–65 ton, Rev F unit has the option for a Hot Gas Reheat (HGRH) system. A HGRH system allows a standard DX cooling unit to provide dehumidification of the supply air.

### HGRH System

- HGRH is a factory installed option
- Unit will have a HGRH coil installed after the standard DX evaporator coil
- Uses the refrigerant discharge gas from compressor circuit 2
- Reduces the amount of available cooling stages
- HGRH must be set to **INSTALLED** in the UNIT DATA subsection for the HGRH system to operate if installed
- Allows for Dehumidification (Dehum) Control
- Unit Controller will modulate a 3-way stepper valve to control the amount of discharge gas to the HGRH coil
- Adds sensible heat to the supply air being delivered to the space. This allows the DX evaporator coil to operate at a lower temperature, removing excess moisture without negatively affecting personal comfort
- HGRH coil has a HGRH Bleed Solenoid Valve installed.
  - HGRH Bleed Solenoid Valve is connected between the HGRH coil and the CKT 2 suction line.
  - HGRH Bleed Solenoid Valve bleeds off any remaining/trapped oil or liquid refrigerant in the HGRH coil when HGRH is inactive

- HGRH Bleed Solenoid Valve is normally closed and will be energized whenever HGRH is inactive
- HGRH cannot be installed on Flexsys configured units

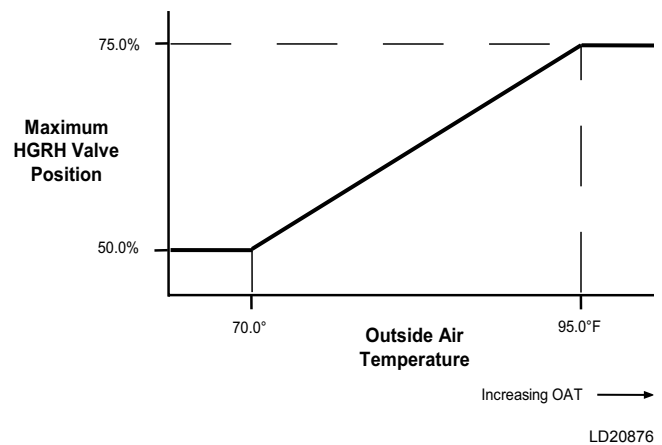
### HRGH 3-Way Stepper Valve

- The HGRH 3-way stepper valve (*Figure 41 on page 91*) is controlled by its own separate controller (Sporlan IB-G Controller)
- The HGRH system uses a Sporlan 3-way modulating stepper valve (MTW-17)
- The HGRH valve will allow for control of the refrigerant discharge gas from refrigerant CKT 2 to either the condenser coil and/or the HGRH coil
- The stepper motor is an integral component of the HGRH valve and cannot be replaced individually
- Once energized for Dehum Control, the HGRH valve will modulate between a minimum and maximum position
  - Minimum Position: 25% (this is a fixed setting and cannot be changed)
  - Maximum Position: Will vary based on the current OAT. Refer to *Figure 42 on page 91*.
    - If OAT is less than/equal to 70 °F, the Max position will be 50%
    - If OAT is greater than/equal to 95 ° F, the Max position will be 75%
    - If the OAT is between 70 °F and 95 °F, the Max position will be somewhere between 50% and 75%
- Outlet A will be piped to the condenser
- Outlet B will be piped to the HGRH coil



LD20876

**FIGURE 41 - HGRH 3-WAY STEPPER VALVE**



LD20876

**FIGURE 42 - MAX HGRH VALVE POSITION VS. OAT**

### HGRH Control Board

- The HGRH Controller (*Figure 43 on page 92*) is factory installed and programmed. No field set-up is required.
- The HGRH Controller is powered by 24 VAC
- The HGRH Controller receives a 0–10 VDC signal from the Unit Controller. The HGRH Controller will use this 0-10 VDC signal to modulate the valve open/closed through pulsed signals.
- The 0–10 VDC signal will be provided from TB9 terminals 11 and 12 of the I/O board (these terminals are used for control of the Bypass Damper on a Flexsys configured unit)
- The HGRH Controller has 3 LEDs that can be used as a reference
  - Red LED: The status LED is lit whenever the controller has 24 VAC power
  - Yellow LED: The Closed LED is only lit whenever the valve is fully closed
  - Green LED: The valve open LED flashes in different sequences depending on the valve position.
    - One Flash = Valve position between 0–10%
    - Two Flashes = Valve between 10–20%
    - Three Flashes = Valve between 20–30%
    - Four through Ten Flashes will follow the pattern in the previous three steps
- The green LED will remain lit whenever the valve is fully open

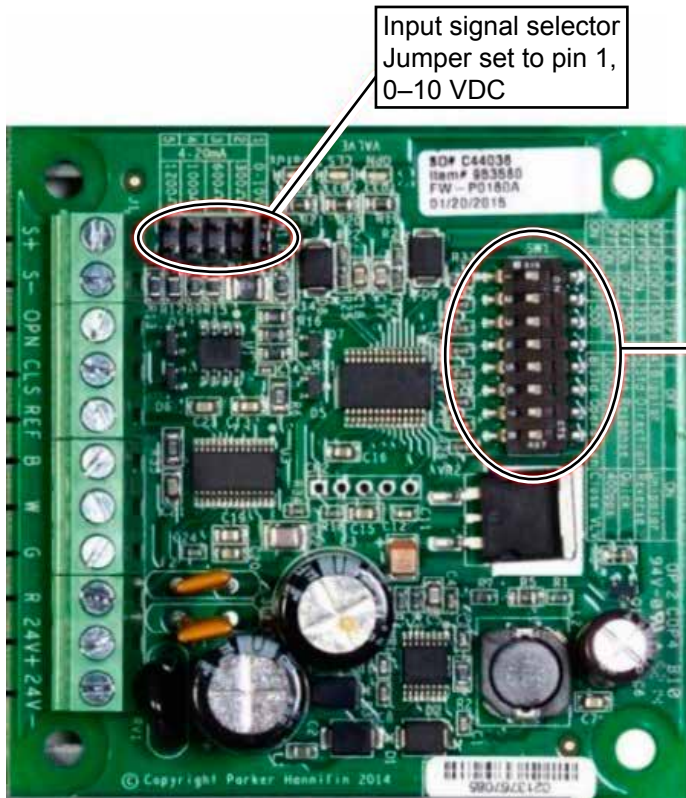
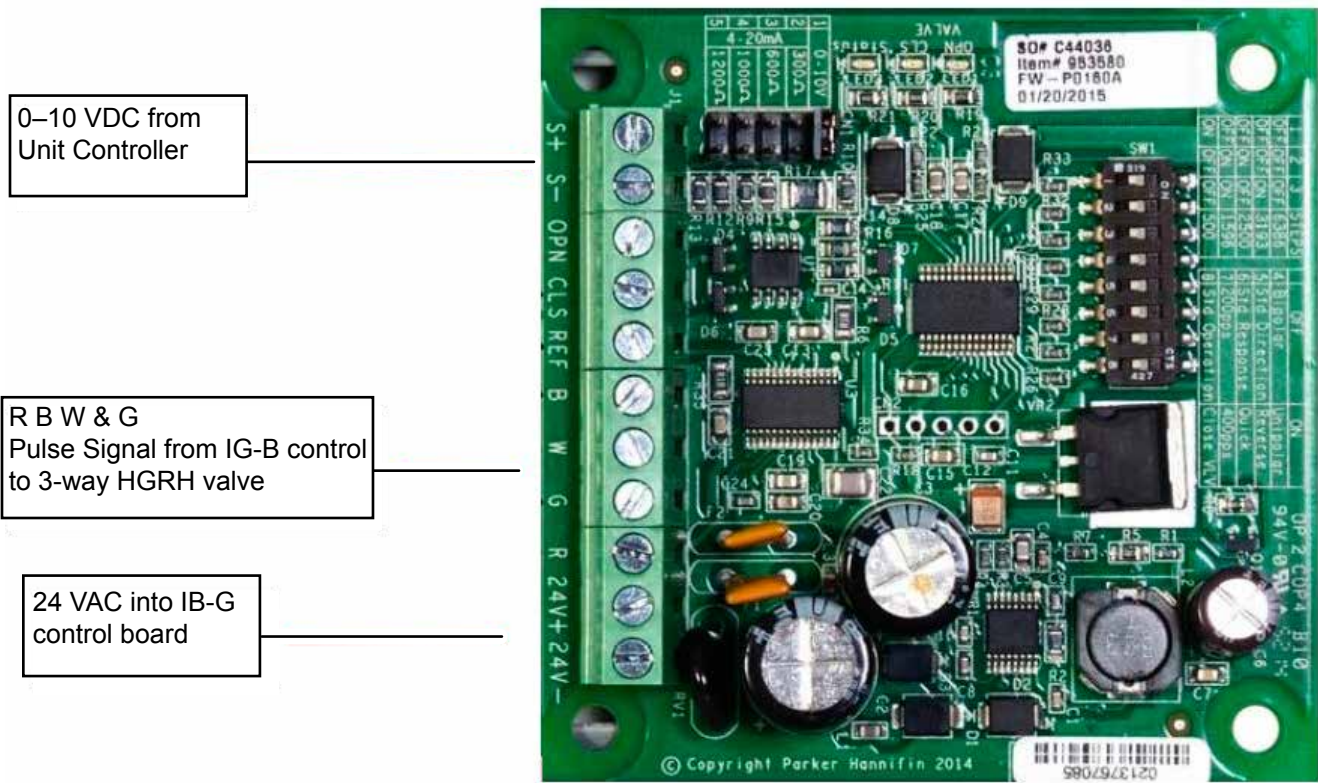


TABLE 38 - INPUT SIGNAL (JUMPER LOCATION)

5	4	3	2	1
4-20mA				0-10V
1200Ω	1000Ω	600Ω	300Ω	

SW1: HGRH Valve configuration  
All switches should be set to the OFF position

TABLE 39 - NUMBER OF STEPS

	6386	3196	2500	1596	500
1	OFF	OFF	OFF	OFF	ON
2	OFF	OFF	ON	ON	OFF
3	OFF	ON	OFF	ON	OFF

TABLE 40 - VALVE TYPE

	OFF	ON
4	Bipolar	Unipolar
5	Std Direction	Reverse
6	Std Response	Quick
7	200pps	400pps
8	Std Operation	Close Valve

LD20878 and LD20879

FIGURE 43 - HGRH CONTROL BOARD

### HGRH Bleed Solenoid Valve

- 24 VAC
- The HGRH bleed solenoid valve connects the HGRH coil to the circuit 2 suction line
- Bleeds off any remaining or trapped liquid in the HGRH coil when HGRH is inactive

- The HGRH bleed solenoid is a normally closed valve. It will be opened (energized) whenever the HGRH system is inactive.
- 5-minute delay before opening after HGRH goes inactive

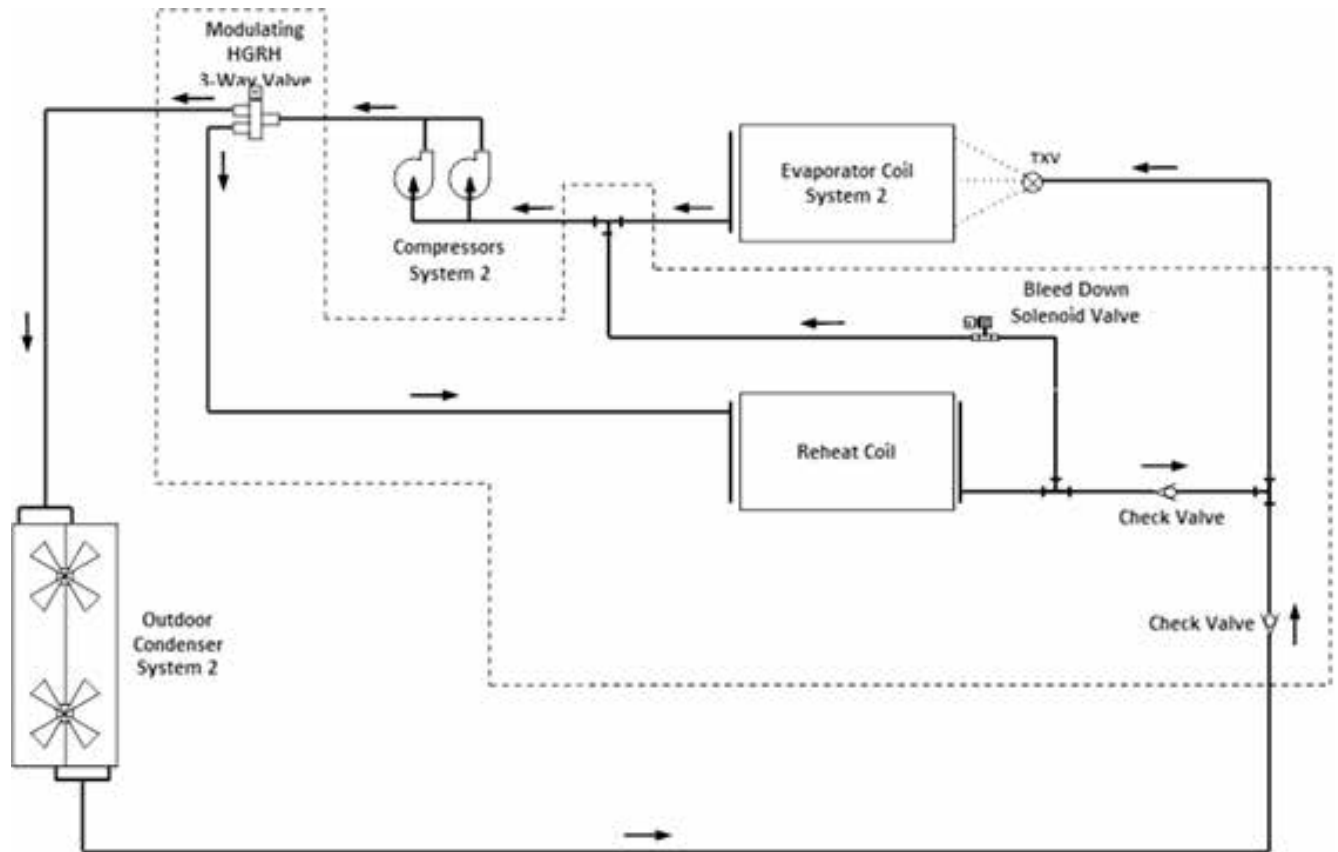


FIGURE 44 - HGRH PIPING LAYOUT

LD20880

### HGRH Set-Up

- HGRH is a factory installed option
- Unit Controller configured for VAV or SZVAV
- HGRH is set to INSTALLED: OPTIONS key / UNIT DATA subsection
- Dehum Control is set to USER ENABLED: Unit will have a combination RAT/humidity sensor installed
- Unit will have a combination SAT/humidity sensor installed
- Unit will have an evaporator leaving air temp sensor installed (four separate sensors wired in an averaging configuration)

### HGRH Status

The HGRH system status will be shown as one of the five states listed below:

#### **User Disabled**

- Dehum Control has been set to USER DISABLED (either at the Unit Controller, or thru the BAS)

#### **Inactive**

Any of the below requirements are satisfied:

- The unit is not running in an Active Cooling mode (OCC or UNOCC)
- OAT is less than 54.0 °F

- Dehumidification is not required
- No active HGRH faults exist

**Ready**

All of the below requirements are satisfied:

- Unit is running in an Active Cooling mode (OCC or UNOCC)
- OAT is greater than/equal to 55.0 °F
- Dehumidification is required
- "SADP ACTIVE" setpoint is less than/equal to "HGRH SAT ACTIVE" setpoint minus 5 °F
- At least 3 minutes has elapsed since HGRH status was last ACTIVE
- No active HGRH faults

**Active**

All of the below requirements have been satisfied:

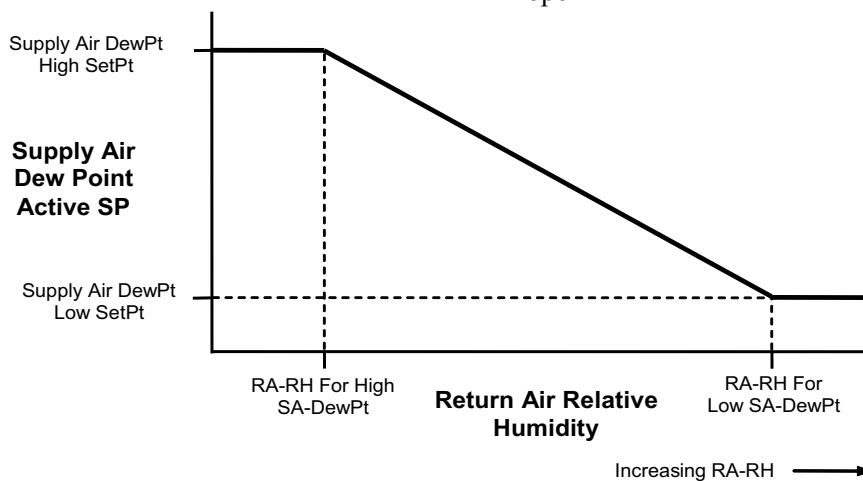
- All of the conditions for READY have been satisfied
- At least one compressor from circuit 2 has been running for at least 5 minutes
- No active HGRH faults exist

**Faulted**

- Unit Controller determines there is an active HGRH fault

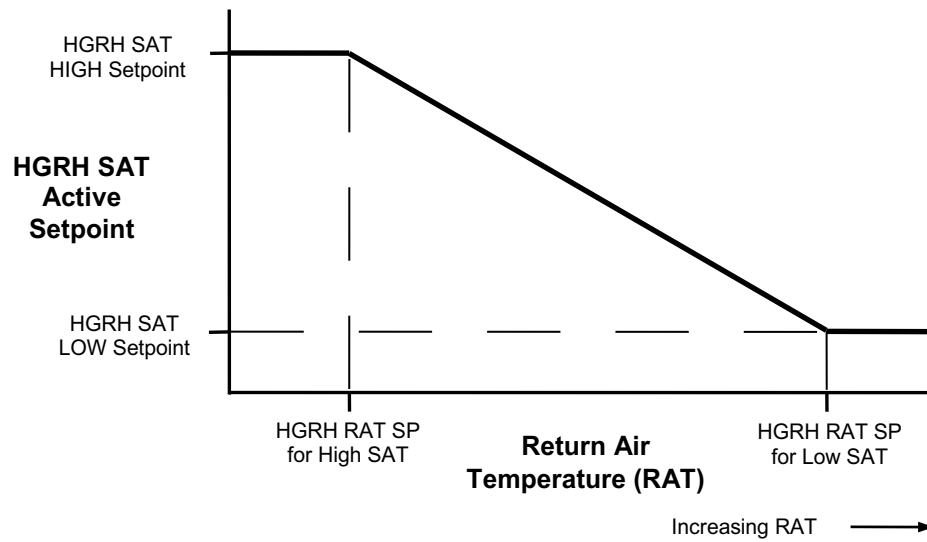
**HGRH Sequence of Operation**

- HGRH is set to INSTALLED
- Dehum Control is set to USER ENABLED
- OAT is greater than/equal to 55.0 °F
- Unit is operating in an Active Cooling mode (OCC or UNOCC)
- If the "SADP ACTIVE" setpoint becomes less than/equal to the "HGRH SAT ACTIVE" setpoint minus 5 °F, the Unit Controller will send the appropriate 0–10 VDC signal to the HGRH control board
  - The "SADP ACTIVE" setpoint will be a calculated value based off *Figure 45 on page 94*
- The Unit Controller will de-energize the HGRH bleed solenoid, causing the valve to close
- The Unit Controller will monitor the current SAT and send a 0–10 VDC signal to the HGRH control board to modulate the HGRH valve open/closed to achieve and maintain the "HGRH SAT ACTIVE" setpoint
  - The "HGRH SAT ACTIVE" setpoint is a calculated value based off *Figure 46 on page 95*
- Once the demand for dehumidification is satisfied, or the Unit Controller exits an Active Cooling mode, the HGRH valve will close, and after a 5-minute time delay, the Unit Controller will energize the HGRH bleed solenoid, causing it to open



LD20881

**FIGURE 45 - SUPPLY AIR DEW POINT ACTIVE SETPOINT VS. RETURN AIR HUMIDITY**



LD21611

5

**FIGURE 46 - HGRH SAT ACTIVE SETPOINT VS. RETURN AIR TEMPERATURE**

### HGRH Faults

1. HGRH Fault 1: All the below conditions have been active for 5 minutes
    - a. HGRH is INSTALLED
    - b. HGRH Status is INACTIVE
    - c. Any compressor from CKT 2 is ON
    - d. Current SAT is greater than/equal to "CURRENT EVAP AIR TEMP" plus 8.0 °F for more than 5 minutes
  2. HGRH Fault 2: All the below conditions have been active for 5 minutes
    - a. HGRH is INSTALLED
    - b. HGRH Status is ACTIVE
    - c. HGRH valve position is greater than/equal to 50%
    - d. Current SAT is less than/equal to "CURRENT EVAP AIR TEMP" plus 8.0 °F for more than 5 minutes
  3. HGRH Fault 3: All the below conditions have been active for 5 minutes
    - a. CKT 2 has a discharge pressure transducer installed
    - b. HGRH is INSTALLED
    - c. CKT 2 discharge pressure is greater than/equal to 90% on the "SYSTEM 2 UNLOADING PRESSURE"
- If any of the previous fault conditions exist, the Unit Controller will:
1. Turn off Comp 2A and/or 2B if they are running
  2. Display HGRH status as FAULTED
  3. Display a COOLING/HEATING FAULT
  4. Display a LOCKOUT-COMPRESSOR SYSTEM 2
  5. The LOCKOUT-COMPRESSOR SYSTEM 2 cannot be cleared until the HGRH status is NORMAL

## CONDENSER FAN CONTROL

The Series 100, 50–65 ton unit has four condenser fans. The Unit Controller will cycle condenser fans ON/OFF based on OAT, number of compressors ON per system, and the current discharge pressure (if applicable).

### Ambient Control

Whenever a compressor is cycled ON, a condenser fan output will be turned ON. The number of condenser fans running at any given time will be based on the following tables.

**TABLE 33 - ONE COMPRESSOR ON PER ANY SYSTEM**

OUTSIDE AIR TEMP	CONDENSER FAN OUTPUT			
	1A	1B	2A	2B
-20.0 °F THRU 59.0 °F	ON	OFF	OFF	OFF
60.0 °F THRU 79.0 °F	ON	ON	OFF	OFF
80.0 °F THRU 89.0 °F	ON	ON	ON	OFF
90.0 °F THRU 181.0 °F	ON	ON	ON	ON

**TABLE 34 - TWO COMPRESSOR ON PER ANY SYSTEM**

OUTSIDE AIR TEMP	CONDENSER FAN OUTPUT			
	1A	1B	2A	2B
-20.0 °F THRU 59.0 °F	ON	OFF	OFF	OFF
60.0 °F THRU 72.0 °F	ON	ON	OFF	OFF
73.0 °F THRU 79.0 °F	ON	ON	ON	OFF
80.0 °F THRU 181.0 °F	ON	ON	ON	ON

### Ambient Plus Discharge Pressure Control

If the compressor system has a discharge pressure transducers installed, the condenser fans will be staged ON/OFF per the above tables AND the refrigerant discharge pressure.

- "PRESS TRANS PKG" must be set to the appropriate value: SYS 1 or SYS 1,2
- When a compressor system initially starts, the condenser fans will be controlled per the above tables
- After 5 minutes has passed allowing the refrigerant pressures to stabilize, the Unit Controller will monitor the discharge pressure for any system that has a discharge pressure transducer installed

- The Unit Controller will start another condenser fan if the highest discharge pressure of any system is greater than 360 psig and the lowest discharge pressure is no less than 300 psig
- The Unit Controller will stop a condenser fan if the lowest discharge pressure of any system is less than 260 psig, and the highest discharge pressure of any system is no greater than 350 psig
- Anytime a condenser fan is turned ON/OFF, a 60-second timer is started. No additional fans can be started or stopped during this 60-second interval.

## ECONOMIZER

The Series 100 unit can be ordered with an optional factory-installed economizer. An economizer will provide "free cooling" during times when the OAT is too cold for mechanical cooling. The economizer sequence is a completely different sequence than ventilation even though both use the OA damper. The unit must be in Active Cooling mode for the economizer to become active.

There are three economizer types:

- **Dry Bulb:** Economizer suitability determined by OAT only
- **Single Enthalpy:** Economizer suitability determined by OAT and OA relative humidity
- **Dual Enthalpy:** Economizer suitability determined by comparing the OAT and OA relative humidity against the RAT and RA relative humidity

### Dry Bulb

#### Sequence of Operation

- "ECONOMIZER TYPE" is DRY BULB
- Economizer is USER ENABLED
- Unit Controller must see a valid OAT
- If current OAT is 2.0 °F less than "OA DRY BULB" setpoint, economizer will become active
- Unit Controller will modulate OA damper to try to achieve and maintain "ACTIVE COOLING SAT" setpoint

### Single Enthalpy

#### Sequence of Operation

- "ECONOMIZER TYPE" is SINGLE ENTHALPY
- Economizer is USER ENABLED



- Unit Controller must see a valid OAT and OA relative humidity
- Economizer will become active if:
  - Current OAT is 2.0 °F less than "*OA DRY BULB*" setpoint
  - AND
  - Current OA Enthalpy is less than "*OA ENTHALPY*" setpoint
- Unit Controller will modulate OA damper to try to achieve and maintain "*ACTIVE COOLING SAT*" setpoint

### Dual Enthalpy

#### Sequence of Operation

- "*ECONOMIZER TYPE*" is DUAL ENTHALPY
- Economizer is USER ENABLED
- Unit Controller must see a valid OAT, OA relative humidity, RAT, and RA relative humidity
- Economizer will become active if:
  - Current OAT is 2.0 °F less than "*OA DRY BULB*" setpoint
  - AND
  - Current OA Enthalpy is 1 btu/lb less than "*RA ENTHALPY*" setpoint
- Unit Controller will modulate OA damper to try to achieve and maintain "*ACTIVE COOLING SAT*" setpoint

#### Best Method

- Unit Controller gives option to set "*ECONO METHOD TO USE*" to BEST METHOD
- When set to BEST METHOD, the Unit Controller will monitor different sensors used for the three different economizer types, and if a sensor reading becomes invalid, the economizer method used will switch to a different method
- Example:

If the "*ECONOMIZER TYPE*" is DUAL ENTHALPY and the RA humidity sensor reading becomes invalid, the Unit Controller will try to control the economizer as Single Enthalpy if "*ECONO METHOD TO USE*" is set to BEST METHOD

## HEATING OPERATION

The Series 100 unit can be ordered with different heating options. They are:

- None
- Electric Heat
- Staged Gas
- Modulating Gas
- Steam Heat
- Hot Water Heat

### Electric Heat

The following data MUST be entered

- Heating system MUST be USER ENABLED
- "*HEATING SYS TYPE*" MUST be set to ELECTRIC
- "*ELECT HEAT CAPACITY*" MUST be set to the nameplate capacity

### Constant Volume

- "*1ST AND 2ND STAGE HEATING*" setpoints must be entered

### SZVAV

- "*1ST AND 2ND STAGE HEATING*" setpoints must be entered

### VAV and Flexsys

- "*HEATING SAT*" setpoint must be entered

### Heating Control Offset

- Unit Controller will calculate a "*HEATING CONTROL OFFSET*" based on the KW of heat installed, the CFMs, and the stages of heat
- The "*HEATING CONTROL OFFSET*" will be rounded up to the nearest 1/2 degree.
- If "*HEATING CONTROL OFFSET*" is calculated to be less than 2.0 °F, it will be set to 2.0 °F
- If Unit mode is "*COMFORT VENT HEATING*" or "*SUPPLY AIR TEMPERING*," the "*HEATING CONTROL OFFSET*" will be fixed at 5.0 °F

### Active SAT Setpoint

- VAV: "*HEATING SAT*" setpoint
- CV and SZVAV: "*ZONE SENSOR SAT OCC/UNOCC HEATING*" setpoint

**TABLE 35 - STAGED INPUT SAT HEATING SETPOINT**

Y1 LOW COOL	Y2 HIGH COOL	W1 LOW HEAT	W2 HIGH HEAT	OCC. MODE	UNIT MODE	ACTIVE SP
On	Off	Off	Off	Occupied	Occupied Cooling Low	1st stage cooling setpoint
On/Off	On	Off	Off	Occupied	Occupied Cooling High	2nd stage cooling setpoint
Off	Off	On	Off	Occupied	Occupied Heating Low	1st stage heating setpoint
Off	Off	On/Off	On	Occupied	Occupied Heating High	2nd stage heating setpoint
Off	Off	Off	Off	Occupied	Occupied Standby ( <i>See Comfort Ventilation on page 111</i> )	None
On	Off	Off	Off	Unoccupied	Unoccupied Cooling Low	1st stage cooling setpoint
On/Off	On	Off	Off	Unoccupied	Unoccupied Cooling High	2nd stage cooling setpoint
Off	Off	On	Off	Unoccupied	Unoccupied Heating Low	1st stage heating setpoint
Off	Off	On/Off	On	Unoccupied	Unoccupied Heating High	2nd stage heating setpoint
Off	Off	Off	Off	Unoccupied	Unoccupied Standby	None

**TABLE 36 - ZONE TEMPERATURE HEATING SETPOINTS**

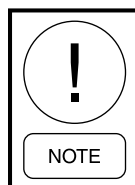
$\Delta T_{OC}$ OCC COOL	$\Delta T_{OH}$ OCC HEAT	$\Delta T_{UC}$ UNOCC COOL	$\Delta T_{UH}$ UNOCC HEAT	OCCUPANCY MODE	UNIT MODE	ACTIVE SP
> 0.5 °F	---	---	---	Occupied	Occupied Cooling Low	1st Stage Cooling Setpoint
> 1.5 °F	---	---	---	Occupied	Occupied Cooling High	2nd Stage Cooling Setpoint
---	< -0.5 °F	---	---	Occupied	Occupied Heating Low	1st Stage Heating Setpoint
---	< -1.5 °F	---	---	Occupied	Occupied Heating High	2nd Stage Heating Setpoint
---	---	---	---	Occupied	Occupied Standby ( <i>See Comfort Ventilation on page 111</i> )	None
---	---	> 0.5 °F	---	Unoccupied	Unoccupied Cooling Low	1st Stage Cooling Setpoint
---	---	> 1.5 °F	---	Unoccupied	Unoccupied Cooling High	2nd Stage Cooling Setpoint
---	---	---	< -0.5 °F	Unoccupied	Unoccupied Heating Low	1st Stage Heating Setpoint
---	---	---	< -1.5 °F	Unoccupied	Unoccupied Heating High	2nd Stage Heating Setpoint
---	---	---	---	Unoccupied	Unoccupied Standby	None

**Sequence of Operation**

- Unit Controller enters an Active Heating mode:
  - Occ Heating
  - Unocc Heating
  - Comfort Vent Heating
  - Supply Air Tempering
  - Morning Warm-Up

- Unit Controller will determine the initial stages of heat needed

- Unit Controller will start the required stages of heat



**"COMFORT VENT HEATING" and "SUPPLY AIR TEMPERING" will bring on one stage at a time.**

- After expiration of the 3.5-minute Interstage Delay Timer, the Unit Controller will cycle ON/OFF stages of heat based on the Heating Control Logic

## Staged Gas Heat

- The following data must be entered
  - Heating system MUST be USER ENABLED
  - "HEATING SYS TYPE" MUST be set to STAGED GAS
  - "STAGED GAS HEAT CAPACITY" MUST be set to the nameplate capacity
  - Heat limit temperature MUST be programmed
- The unit can have either 1, 2, or 3 gas burner sections
- Each section will consist of a two stage gas valve, a Ignition Control, an induced draft motor, and high limit and rollout switches independent of the other burner sections
- The gas heat sections operation will be monitored by the Digital Multi-Plexer
- The Digital Multi-Plexer will receive a 24 VAC status input from each Ignition Control
- The Digital Multi-Plexer will convert the 24 VAC status input to a 0–5 VDC output signal to the Unit Controller based on the operational status of each burner section
- Unit Controller monitors the time it takes to go between stages of operation and the specified operation state. The following states will be shown under the HEATING key, FURNACE # MODE:
  - PURGE
  - TRY FOR IGNITION
  - ON-LOW
  - ON-HIGH
  - SAFETY TRIP
  - SAFETY FAULT
  - SAFETY LOCKOUT
  - FAULT-LOCKOUT

## Constant Volume

- "1ST AND 2ND STAGE HEATING" setpoints must be entered

## SZVAV

- "1ST AND 2ND STAGE HEATING" setpoints must be entered

## VAV and Flexsys

- "HEATING SAT" setpoint must be entered

## Heating Control Offset

- Unit Controller will calculate the "HEATING CONTROL OFFSET" based on the minimum firing rate, the CFMs, and the required temperature rise across the heat exchangers
- The "HEATING CONTROL OFFSET" will be rounded up to the nearest 1/2 degree
- If "HEATING CONTROL OFFSET" is calculated to be less than 2.0 °F, it will be set to 2.0 °F
- If Unit mode "COMFORT VENT HEATING" or "SUPPLY AIR TEMPERING," the "HEATING CONTROL OFFSET" will be fixed at 5.0 °F

## Active SAT Setpoint

- VAV: "HEATING SAT" setpoint
- SZVAV will utilize *Table 32 on page 81*
- CV will utilize the "ACTIVE SUPPLY AIR TEMP" setpoint based on *Table 31 on page 80* or *Table 32 on page 81*

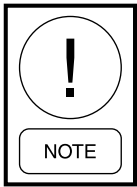
## Heating Control

- The Unit Controller will use the current SAT to determine when to cycle additional stages of heat ON/OFF
- If SAT is less than the SAT setpoint minus the "HEATING CONTROL OFFSET," an additional stage of heat will be started
- If SAT is greater than the SAT setpoint plus the "HEATING CONTROL OFFSET," an additional stage of heat will be stopped
- If SAT plus 2 times the "HEATING CONTROL OFFSET" is more than/equal to the heat limit temperature, additional stages of heat will be prevented from starting

## Sequence of Operation

- Unit Controller enters an Active Heating mode
  - Occ Heating
  - Unocc Heating
  - Comfort Vent Heating
  - Supply Air Tempering
  - Morning Warm-Up

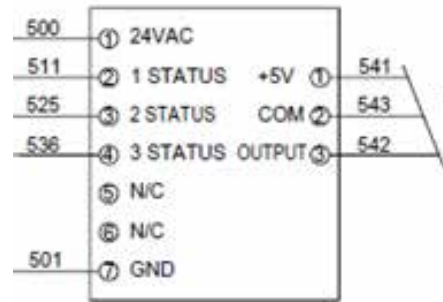
- Unit Controller will determine the initial stages of heat needed
- Unit Controller will start the required stages of gas heat



**"COMFORT VENT HEATING" and "SUPPLY AIR TEMPERING" will bring on one stage at a time.**

- After expiration of the 3.5 min 3.5-minute Inter-stage Delay Timer, the Unit Controller will cycle ON/OFF stages of heat based on the Heating Control Logic
- Each burner section will follow the same ignition sequence
  - Ignition Control (Furnace 1 starts first) receives a 24 VAC input from Unit Controller
  - Ignition Control closes internal contacts which start the Induced Draft Motor
  - Induced Draft Motor comes up to speed, which closes pressure switch
  - 24 VAC runs through pressure switch and two limit switches
  - After a 30-second Purge delay, Ignition Control simultaneously produces a high voltage spark and outputs 24 VAC to the Lo Fire solenoid of gas valve for 7 seconds
  - Ignition Control monitors flame rectification signal. If the signal is present for 15 seconds, 24 VAC is sent to the appropriate terminal of the Digital Multi-Plexor. The multiplexor will then send a 0–5 VDC signal to the Unit Controller confirming operation.
  - Burner 1 will now be in Low Fire. If Unit Controller determines more heat is needed, 24 VAC will be sent to High Fire solenoid of the gas valve.
  - If more heat is needed and there are the appropriate burner sections, they will follow the above sequence
  - If flame rectification is not present, Ignition Control turns off high voltage and 24 VAC to gas valve, waits 30 seconds, then restarts the ignition sequence

- Ignition sequence will be tried three times. If successful ignition is not established after three attempts, the burner section will be locked out for one hour or until the 24 VAC input to Ignition Control is removed.



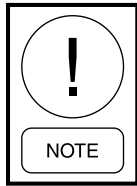
LD21612

**FIGURE 47 - DIGITAL MULTI-PLEXER CONNECTIONS: STAGED GAS HEAT**

### Modulating Gas Heat

- The following data **MUST** be entered
  - Heating system **MUST** be USER ENABLED
  - **"HEATING SYS TYPE"** **MUST** be set to MODULATING GAS HEAT
  - **"MODULATING GAS HEAT CAPACITY"** **MUST** be set to the nameplate capacity
- The unit can have either 1, 2, or 3 gas burner sections
- Unlike Staged Gas, furnace section 1 will be split into two halves
  1. Right-hand side will be modulating (1A) and will have the following:
    - a. Two stage gas valve
    - b. Modulating gas valve
    - c. Ignition Control
    - d. Limit and roll out switches
  2. Left-hand side will be staged (1B) and will have the following
    - a. Two stage gas valve
    - b. Ignition Control
    - c. Limit and roll out switches
- Furnace section 1 will have a shared 2 speed induced draft motor
- Modulating half (1A) of furnace section 1 will **ALWAYS** be first ON and last OFF (unless a fault exists)

- Staged half (1B) of furnace section 1 will ALWAYS be last ON and first OFF (unless a fault exists)



***A fault on 1A will also cause 1B to be in a fault condition.***

- Burner sections 2 and 3 will have a 2 stage gas valve, single speed induced draft motor
- All furnace sections will have high limit and roll out switches independent of each other
- The gas heat section's operation will be monitored by the Digital Multi-Plexer
- The Digital Multi-Plexer will receive a 24 VAC status input from each Ignition Control.
- The Digital Multi-Plexer will convert the 24 VAC status input to a 0–5 VDC output signal to the Unit Controller based on the operational status of each burner section
- Furnace # mode will be the same as Staged Gas
  - PURGE
  - TRY FOR IGNITION
  - ON-LOW
  - ON-HIGH
  - SAFETY TRIP
  - SAFETY FAULT
  - SAFETY LOCKOUT
  - FAULT-LOCKOUT

### **Constant Volume**

- "1ST AND 2ND STAGE HEATING" setpoints must be entered

### **SZVAV**

- "1ST AND 2ND STAGE HEATING" setpoints must be entered

### **VAV and Flexsys**

- "HEATING SAT" setpoint must be entered

### **Heating Control Offset**

- Fixed at 1.5 °F for Modulating Gas Heat

### **Active SAT Setpoint**

- VAV and Flexsys will utilize the "HEATING SAT" setpoint
- SZVAV will utilize Table 32 on page 81
- CV will utilize the "ACTIVE SUPPLY AIR TEMP" setpoint based on Table 31 on page 80 or Table 32 on page 81

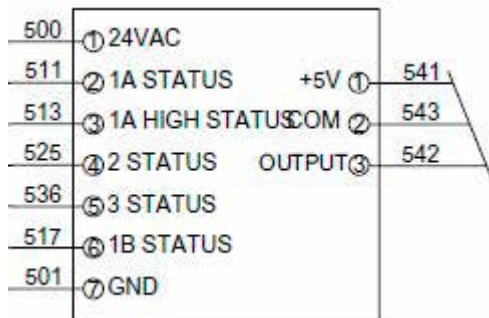
### **Heating Control**

- The Unit Controller will use the current SAT to determine when to cycle additional stages of heat ON/OFF
- If SAT is less than the SAT setpoint minus the "HEATING CONTROL OFFSET," the heating system will be in the Increase mode
- If SAT is greater than the SAT setpoint plus the "HEATING CONTROL OFFSET," the heating system will be in the Decrease mode

### **Sequence of Operation**

- Ignition Control (Furnace 1A starts first) receives a 24 VAC input from Unit Controller
- At the same time, Unit Controller sends 24 VAC signal to 6R (High Fire Relay) to place induced draft motor on High Speed and gas valve in High Fire
- Induced Draft Motor comes up to speed and both low and high pressure switches close
- After a 30-second Purge delay, Ignition Control will:
  - Produce a high voltage spark for 7 seconds
  - Send 24 VAC to Low and High Fire solenoids of the gas valve
  - Modulate the mod gas valve to Min High Fire
- Ignition Control checks for flame rectification. If present for 15 seconds:
  - Ignition Control sends a 24 VAC signal to Digital Multi-Plexer
  - Multi-Plexer sends a 0–5 VDC to Unit Controller
  - Unit Controller removes 24 VAC from 6R, which switches Inducer to Low Speed and mod gas valve to Low Fire.
  - Mod gas valve is modulated to Min Low Fire

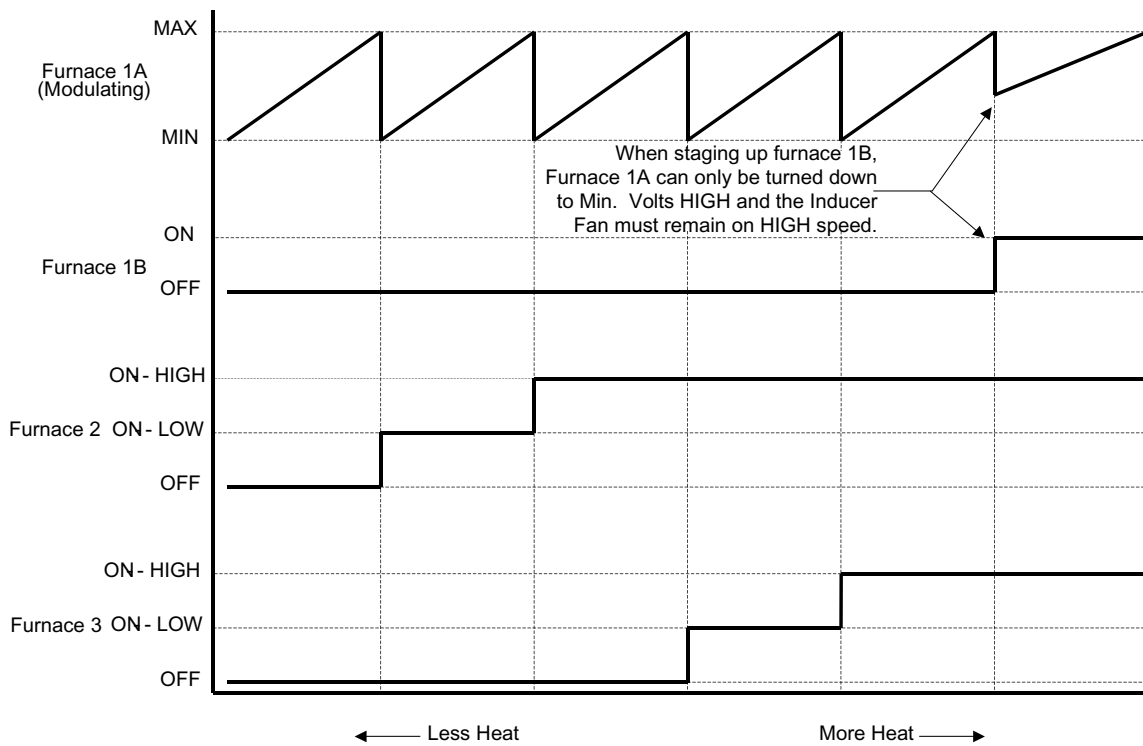
- Furnace 1A is now in Modulation mode
- If flame rectification is not present, Ignition Control and Unit Controller will remove signals for heating operation, wait 30 seconds, then restart the ignition sequence
- Ignition sequence will be tried three times. If successful ignition is not established after three attempts, the burner section will be locked out for one hour or until the 24 VAC input to Ignition Control is removed.
- Furnace sections 2, 3, and 1B will follow same firing sequence as Staged Gas



LD21613

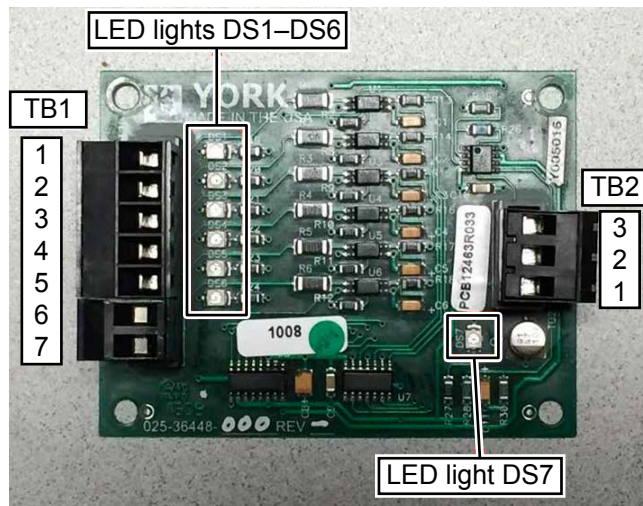
**FIGURE 48 - DIGITAL MULTI-PLEXER CONNECTIONS: MODULATING GAS HEAT**

- Once 1A is in Modulation mode, it will modulate from Low Fire to High Fire depending on the demand for heat
- When 1A is in Low Fire, the Low Fire Solenoid will be powered and the mod gas valve will modulate from Low to High
- When 1A is in High Fire, the High Fire Solenoid will be powered and the mod gas valve will modulate from Low to High
- When staging UP, 1A must be in High Fire High, mod gas valve at maximum, and staged valve on High Fire before the next stage can be started
- When staging DOWN, 1A must be in Low Fire Low, mod valve at minimum, and staged valve on Low Fire before the next stage can be stopped
- 1A in High Fire High and Unit Controller has demand for more heat:
  - 1A drop to Low Fire Low
  - Next available stage is brought on: 2, 3, or 1B
  - Stages 2 or 3 will start on Low Fire
  - 1A will modulate from Low Fire Low to High Fire High
  - If still more heat needed:
    - 1A modulates to Low Fire Low
    - Stage 2 or 3 goes to High Fire
    - 1A will again modulate from Low Fire Low to High Fire High
    - This same sequence will be used until 1B is needed
- 1B will always start on High Fire



LD010151

**FIGURE 49 - MODULATING GAS HEAT STAGING SEQUENCE**



**FIGURE 50 - GAS HEATING FURNACE MULTI-PLEXER BOARD (STAGED AND MODULATING GAS HEAT)**

**Gas Heating Furnace Multi-Plexer Board**

The Gas Heating Furnace Multi-Plexer Board uses 24 VAC inputs from the different furnace sections in a Series 100 unit with the IPU Controller and converts the 24 VAC inputs to a 0–5 VDC output. The 0–5 VDC output is sent to the Unit Controller.

**TB1 and LED Lights DS1–DS6**

- TB1 is used for the 24 VAC inputs from the different sections in the Series 100 unit
- TB1 inputs on Staged Gas Heat:
  - TB1-1: 24 VAC input from T5 transformer (DS1 is lit)
  - TB1-2: 24 VAC input from Furnace 1, DS2 is lit (375 MBH heating capacity)
  - TB1-3: 24 VAC input from Furnace 2, DS3 is lit (750 MBH heating capacity)
  - TB1-4: 24 VAC input from Furnace 3, DS4 is lit (1125 heating capacity)
  - TB1-5: Not used on Staged Gas Heat
  - TB1-6: Not used on Staged Gas Heat
  - TB1-7: 24 VAC common from T5 transformer
- TB1 inputs on Modulating Gas Heat:
  - TB1-1: 24 VAC input from T5 transformer (DS1 is lit)
  - TB1-2: 24 VAC input from Furnace 1A, DS2 is lit (375 MBH heating capacity)

- TB1-3: 24 VAC input from Furnace 1A High, DS3 is lit (375 MBH heating capacity)
- TB1-4: 24 VAC input from Furnace 2, DS4 is lit (750 MBH heating capacity)
- TB1-5: 24 VAC input from Furnace 3, DS5 is lit (1125 MBH heating capacity)
- TB1-6: 24 VAC input from Furnace 1B, DS6 is lit (375, 750, or 1125 heating capacity)
- TB1-7: 24 VAC common from T5 transformer
- The 24 VAC inputs are provided from the V1 terminals of the Ignition Controls except for the 1A High, which is provided when the PS2 pressure switch closes. PS2 pressure switch will close when the induced draft motor on furnace section 1 is on High Speed.
- 24 VAC must be present at TB1-1 and TB1-7 for the Multi-Plexer to function properly. DS1 LED is lit when 24 VAC is present at TB1-1 and TB1-7.

### **TB2 and LED Light DS7**

- TB2 is used to output a 0–5 VDC signal back to the Unit Controller
- TB2 outputs on Staged Gas and Modulating Gas Heat:
  - TB2-1: 5 VDC power from Unit Controller
  - TB2-2: 5 VDC common to Unit Controller
  - TB2-3: 0–5 VDC signal back to Unit Controller
- 5 VDC must be present at TB2-1 and TB2-2 for the Multi-Plexer to function properly. DS7 LED is lit when 5 VDC is present at TB2-1 and TB2-2.
- If 5 VDC is not present at TB2-1 and TB2-2, neither DS1 nor DS7 will be lit

### **Troubleshooting the Multi-Plexer Board**

- Ensure the Mutli-Plexer board has both 5 VDC power and 24 VAC power at the appropriate terminals. A quick check of this can be made by looking at the DS1 and DS7 LEDs. If both LEDs are lit, both power sources are present. If 5 VDC is not present, neither DS1 nor DS7 will be lit. If 5 VDC is present but 24 VAC is not, only DS7 will be lit.

- Multi-Plexer Warnings:
  - *"WRN-FURNACE MULTI-PLEXER FAULT"* (used if the unit has Modulating Gas Heat)
  - *"WRN-GAS FURNACE"* (used if the unit has Staged Gas Heat)
- Ensure the unit's heating capacity matches what is set under the HEATING key
  - On Modulating Gas Heat, Furnace 1 is divided into two halves, 1A and 1B. This correlates to one heating section, and the heating capacity is 375 MBH. 750 MBH will have furnace sections 1A, 1B, and 2. 1125 MBH will have furnace sections 1A, 1B, 2, and 3.
  - On Staged Gas Heat, 375 MBH will have furnace section 1. 750 MBH will have furnace sections 1 and 2. 1125 MBH will have furnace sections 1, 2, and 3.
- If a particular furnace section is lighting and one of the above warnings are present, check for the proper 24 VAC input at TB1 of the Multi-Plexer board. If the 24 VAC input is not present, check for loose or broken wires or loose connections.
- If the proper 24 VAC input is present at TB1, check for the proper 0–5 VDC output from TB2. If the proper 0–5 VDC output is present at TB2, check for 0–5 VDC signal at the Unit Controller.
- Refer to *Tables 61 and 62 on page 185* for Staged Gas and Modulating Gas. These tables show the proper VDC readings the Unit Controller should expect to see for how many stages of heat are calling.

### **Hot Water/Steam Heat**

The following data **MUST** be entered:

- Heating system **MUST** be USER ENABLED
- *"HEATING SYS TYPE"* **MUST** be set to HW/STEAM HEAT
- *"HW VALVE ACTION"* **MUST** be set to either DIRECT or REVERSE

### **Constant Volume**

- *"1ST AND 2ND STAGE HEATING"* setpoints must be entered

### **SZVAV**

- *"1ST AND 2ND STAGE HEATING"* setpoints must be entered



### VAV and Flexsys

- "HEATING SAT" setpoint must be entered

### Active SAT Setpoint

- VAV will utilize the "HEATING SAT" setpoint
- SZVAV will utilize the "ACTIVE SAT" setpoint per *Table 32 on page 81*
- CV will utilize the "ACTIVE SUPPLY AIR TEMP" setpoint based on *Table 31 on page 80* or *Table 32 on page 81*

### Sequence of Operation

- SAT is less than "HEATING SAT" setpoint, valve will modulate open
- SAT is greater than "HEATING SAT" setpoint, valve will modulate closed

### HW/Steam Valve Control

Unit Controller sends a 0–10 VDC signal to the HW/steam valve as described below

- DIRECT: An increase in heating demand will cause the Unit Controller to increase the voltage signal to the valve
- REVERSE: An increase in heating demand will cause the Unit Controller to decrease the voltage signal to the valve

### Freeze Protection

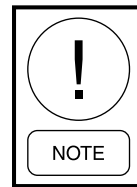
- Unit is not in an Active Heating mode
  - Supply fan is ON
  - Unit Controller will modulate the HW/steam valve open if the SAT falls below 38.0 °F
- OR
- Supply fan is OFF
  - OAT drops below 40.0 °F
  - Unit Controller will send the appropriate signal to the valve
    - 100% if DIRECT
    - 0% if REVERSE

### Freeze Fault

- Unit Controller monitors the status of the Freezestat
- Freezestat Closed = Normal
- Freezestat Open = Fault (opens at 35.0 °F)
- Freezestat opened for 10 seconds = Unit Controller will fully open HW/steam valve
  - 100% if DIRECT
  - 0% if REVERSE
- Unit Controller starts a 5-minute Freeze Trip Timer
  - Freezestat closes during this period, unit resumes normal operation
- If Freezestat remains open after 5-minute timer expires, the Unit Controller will shut down the unit and display a "LOCKOUT-HOT WATER FREEZE"

### Morning Warm-Up

Morning Warm-Up is a function that can be used for any unit type; CV, SZVAV, VAV, and Flexsys. The basic operation is the same for all three set-ups.



**CV units set up for Staged control will not operate in Morning Warm-Up.**

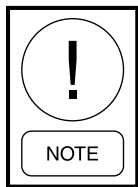
Morning Warm-Up allows for the unit's heating medium to be used to bring the controlled space to a comfortable temperature before personnel arrive.

Morning Warm-Up can be initiated in one of three ways

1. A Morning Warm-Up command from the BAS
2. A command from the Unit Controller utilizing the internal programming schedule
3. 24 VAC input to W1 at CTB1 or a W1 command from the BAS

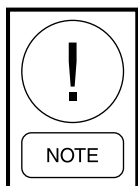
### Morning Warm-Up Set-Up

- The Series 100 unit must have a heating medium installed
- Morning Warm-Up must be USER ENABLED

**Sequence of Operation: Morning Warm-Up**

*It is recommended that all VAV or under-floor boxes are open to their maximum position during Morning Warm-Up operation.*

- The Series 100 unit **MUST** be in an UNOCC mode before Morning Warm-Up can be initiated
- The Series 100 unit receives a Morning Warm-Up command
- The unit's supply fan will start. If a VAV or Flexsys system, the supply fan VFD will control to the "*ACTIVE DUCT STATIC PRESSURE*" setpoint
- After 5 minutes, the Unit Controller will compare the RAT to the "*RAT HEATING*" setpoint
- If the RAT is greater than or equal to the "*RAT HEATING*" setpoint, the heating sequence will not be energized
- If the RAT is less than the "*RAT HEATING*" setpoint by at least 1.0 °F, the Unit Controller will start the unit's heating medium
- Once the heating medium is started, the "*ACTIVE SAT*" setpoint will be as follows:
  - VAV or Flexsys will control to the "*HEATING SAT*"
  - CV and SZVAV will control to the "*2ND STAGE HEATING*" setpoint
- The heating medium will remain ON until
  - The RAT is greater than or equal to the "*RAT HEATING*" setpoint plus 0.5 °F
  - OR
  - The Morning Warm-Up command is removed
  - OR
  - The Series 100 unit enters an OCC mode



*Failure to remove the Morning Warm-Up command or the W1 input from the unit controller will cause the unit to immediately re-enter Morning Warm-Up once an UNOCC mode is entered.*

**Adaptive Morning Warm-Up**

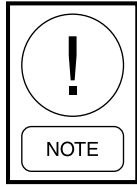
Adaptive Morning Warm-Up will only be utilized when the Series 100 unit is utilizing an internal programming schedule to determine OCC/UNOCC modes.

With Adaptive Morning Warm-Up, the Unit Controller will calculate the start time to ensure that the RAT is within 0.5 °F of the "*RAT HEATING*" setpoint when the unit switches to an OCC mode. This is accomplished by calculating the Morning Warm-Up Optimal Start Time by averaging the amount of time it takes to bring the RAT within 0.5 °F of the "*RAT HEATING*" setpoint for three consecutive days. The three warm-up times are averaged and added to a 10-minute offset. The new time is used as the Morning Warm-Up Optimal Start Time for the next day.

**Adaptive Morning Warm-Up Set-Up**

- "*OCCUPANCY SCHEDULE*" **MUST** be programmed for the OCC and UNOCC start and stop times. This is done through the SCHEDULE key.
- "*OCCUPANCY SCHEDULE*" **MUST** be USER ENABLED
- Morning Warm-Up **MUST** be USER ENABLED
- Adapt Morning Warm-Up **MUST** be USER ENABLED
- "*RAT HEATING*" setpoint **MUST** be set
- "*MORN WARM-UP MAX TIME*" **MUST** be set
- If the "*MORN WARM-UP OPT TIME*" exceeds the "*MORN WARM-UP MAX TIME*," the "*MORN WARM-UP OPT TIME*" will become the "*MORN WARM-UP MAX TIME*"
- If the "*MORN WARM-UP OPT TIME*" is determined to be less than 15 minutes, the "*MORN WARM-UP OPT TIME*" becomes 15 minutes
- The default values for "*DAILY WARM UP TIME [DAY 1], [DAY 2], [DAY 3]*" shall be initially set to 60 minutes. These values can be reset to the default values by turning the Morning Warm-Up to USER DISABLED, then back to USER ENABLED

## Sequence of Operation



*It is recommended that all VAV or under-floor boxes are open to their maximum position during Morning Warm-Up operation.*

- The Series 100 unit MUST be in an UNOCC mode before Morning Warm-Up can be initiated
- The Unit Controller starts the Morning Warm-Up sequence 38
- The supply fan starts. If VAV or Flexsys, the supply fan VFD will be controlled to the "ACTIVE DUCT STATIC PRESSURE" setpoint
- If the RAT is greater than the "RAT HEATING" setpoint minus 1.0 °F, the Unit Controller will not energize the heating sequence and it sets the Daily Warm Up Time to 5 minutes
- If the RAT is less than or equal to the "RAT HEATING" setpoint minus 1.0 °F, the Unit Controller will energize the heating sequence based on the Morning Warm-Up Optimal Start Time
- Once the heating medium is started, the "ACTIVE SAT" setpoint will be as follows:
  - VAV or Flexsys will control to the "HEATING SAT"
  - CV will control to the "2ND STAGE HEATING" setpoint
- The heating medium will remain ON until
  - The RAT is greater than or equal to the "RAT HEATING" setpoint plus 0.5 °F
  - OR
  - The Morning Warm-Up command is removed
  - OR
  - The Series 100 unit enters an OCC mode

## Supply Air Tempering

Supply Air Tempering is a function that is utilized in VAV and Flexsys configured units only. Supply Air Tempering will bring on the unit's heating source to temper the supply air. It is typically used on units that have large requirements of outside ventilation air during the winter months.

When Supply Air Tempering is active, the unit's heating source will temper the SAT and try to maintain the "CURRENT COOLING SAT" setpoint.

## Sequence of Operation

- Heating system MUST be USER ENABLED
- Supply Air Tempering MUST be USER ENABLED
- Modulating Gas or HW/Steam
  - (VAV: "OCC STANDBY" or "OCC COOLING") Current SAT is 2.5 °F less than the "ACTIVE SAT" setpoint for 5 minutes
  - (Flexsys: "OCC STANDBY" or "OCC COOLING W/O BYPASS") MX SAT is 2.5°F less than "ACTIVE MX SAT" setpoint for 5 minutes
  - (Flexsys: "OCC COOLING W/ BYPASS") MX SAT is 2.5 °F less than the "ACTIVE MX SAT" setpoint for 5 mins AND the current flex evap temperature is 5.0 °F less than the "ACTIVE SAT" setpoint for 5 minutes
  - Economizer output is less than/equal to 5%
  - No compressor operation for 10 minutes
- Staged Gas or Electric Heat
  - Same as above AND:
  - Current Heat Entering Temp is 5.0 °F less than the "ACTIVE SAT" setpoint for 5 minutes

## Supply Air Tempering Termination

- Modulating Gas Heat
  - (VAV: "OCC STANDBY" or "OCC COOLING") Current SAT is 4.0 °F greater than the "ACTIVE SAT" setpoint for 5 minutes
  - (Flexsys: "OCC STANDBY" or "OCC COOLING W/O BYPASS") MX SAT is 4.0 °F greater than the "ACTIVE MX SAT" setpoint for 5 minutes
  - Modulating Gas Heat is at Min Low Fire
- HW/Steam
  - (VAV: "OCC STANDBY" or "OCC COOLING") Current SAT is greater than the "ACTIVE SAT" setpoint

- (Flexsys: "OCC STANDBY" or "OCC COOLING W/O BYPASS") Current SAT is greater than the "ACTIVE MX SAT" setpoint for 5 minutes
- HW/Steam Valve position is less than/equal to 2%
- Staged Gas and Electric Heat
  - (VAV: "OCC STANDBY" or "OCC COOLING") current heat entering temperature is greater than the "ACTIVE COOLING SAT" setpoint for 5 minutes
  - (Flexsys: "OCC STANDBY" or "OCC COOLING W/O BYPASS") current heat entering temperature is greater than the "ACTIVE MX SAT" setpoint for 5 minutes

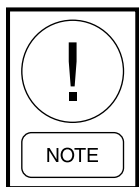
## VENTILATION

Ventilation is a function of bringing in a set amount of fresh outside air to a space. It is a separate function than an economizer, which is part of the cooling mode.

### Damper Hardware

Ventilation on a Series 100 unit can be configured for one of four modes:

1. None
2. 2-Position Damper
3. Standard Damper
4. TEK-Air Full IAQ



***The Series 100, Rev D units could have the below Air Measuring Stations (AMSs) installed as an option. These three options are no longer used in the current Rev F and Rev G units. Please do not enter as a Damper Hardware Type. Erratic operation will occur if selected.***

- a. Minimum IAQ
- b. Full IAQ
- c. 1/3–2/3 IAQ

### Control Options

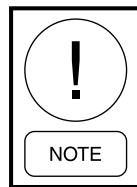
There are two different control options for the Standard Damper and the TEK-Air:

1. Fixed Minimum

2. Demand Ventilation: Requires the unit to have two CO<sub>2</sub> sensors, one indoor and one outdoor (used as a reference). When the indoor CO<sub>2</sub> level exceeds the outdoor CO<sub>2</sub> level by the "CO<sub>2</sub> OFF-SET" setpoint, the O/A dampers will modulate open to lower the indoor CO<sub>2</sub> level.

### Ventilation System Active

- Series 100 unit MUST be in an OCC Mode (ventilation will be inactive in any UNOCC mode)
- The supply fan proving circuit MUST be CLOSED



***If the economizer becomes active, the economizer control logic can open the O/A dampers past the "ACTIVE VENTILATION MINIMUM POSITION" setpoint. The economizer cannot close the O/A dampers below the "ACTIVE VENTILATION MINIMUM POSITION" setpoint.***

### 2-Position Damper

- Ventilation system MUST be USER ENABLED
- Damper hardware MUST be set to 2 POSITION

### Sequence of Operation

- When the ventilation system is active, the Unit Controller will send a 10 VDC signal to the actuator
- When the ventilation system is inactive, the Unit Controller will remove the 10 VDC signal from the actuator
- The amount of outdoor air can be set by adjusting the damper linkages

### Standard Damper

Standard dampers can be set for two control types:

1. Fixed Minimum
2. Demand Ventilation

### Standard Damper w/ Fixed Minimum Control

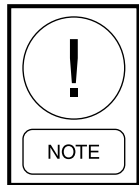
This function is sometimes known as, "The poor man's air measuring station." The Series 100 unit will modulate the O/A dampers between a minimum and maximum position based on the speed of the supply fan VFD.

### Fixed Minimum

- Ventilation system MUST be USER ENABLED
- Damper hardware MUST be set for STANDARD DAMPERS
- Ventilation control MUST be set for FIXED MINIMUM
- "O/A DAMPER MIN POS" and "O/A DAMPER MAX POS" MUST be set

### Standard Dampers w/ Fixed Minimum Control Sequence of Operation

- Supply fan is ON
- Ventilation system is ACTIVE
- Economizer system is INACTIVE



*If economizer becomes active, economizer control logic can open O/A dampers past "ACTIVE VENTILATION MINIMUM POSITION" setpoint. Economizer cannot close O/A dampers below "ACTIVE VENTILATION MINIMUM POSITION" setpoint.*

- Based on the supply fan VFD speed, the O/A dampers will modulate as follows:
  - VFD at 100%: O/A dampers will be at the "O/A DAMPER MIN POS"
  - VFD at 50%: O/A dampers will be at the "O/A DAMPER MAX POS"
  - VFD between 100% and 50%: O/A dampers will modulate between the "O/A DAMPER MIN POS" and "O/A DAMPER MAX POS"

### Standard Damper w/ Demand Ventilation

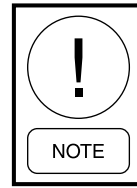
When the Series 100 unit is configured for this option, the O/A dampers will modulate between a minimum and maximum position based on ventilation demand.

### Demand Ventilation

- Ventilation system MUST be USER ENABLED
- Damper hardware MUST be set for STANDARD DAMPERS
- Ventilation control MUST be set for DEMAND VENTILATION
- "O/A DAMPER MIN POS" and "O/A DAMPER MAX POS" MUST be set
- "CO2 OFFSET" setpoint MUST be set

### Sequence of Operation

- Supply fan is ON
- Ventilation system is ACTIVE
- Economizer system is INACTIVE



*If the economizer becomes active, the economizer control logic can open the O/A dampers past the "ACTIVE VENTILATION MINIMUM POSITION" setpoint. The economizer cannot close the O/A dampers below the "ACTIVE VENTILATION MINIMUM POSITION" setpoint.*

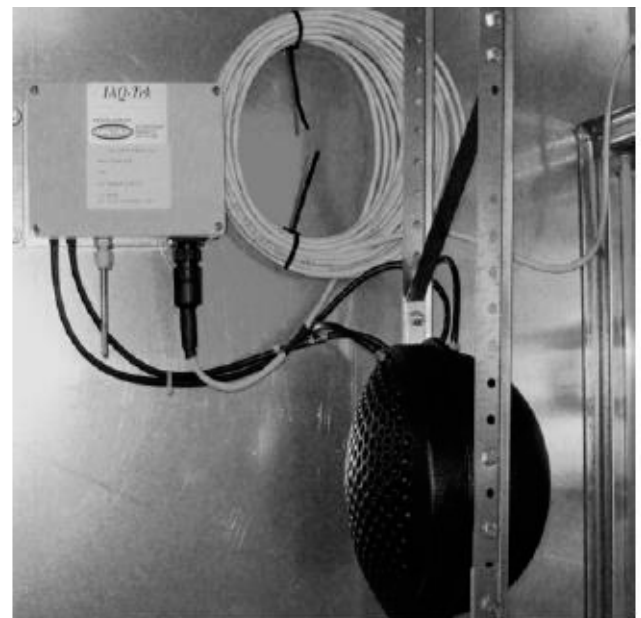
- Based on ventilation demand, the O/A dampers will modulate as follows:
  - Ventilation demand at 0%: O/A dampers will be at the "O/A DAMPER MIN POS"
  - Ventilation demand at 100%: O/A dampers will be at the "O/A DAMPER MAX POS"
  - Ventilation demand between 0–100%: O/A dampers will modulate between the "O/A DAMPER MIN POS" and "O/A DAMPER MAX POS"

5

### TEK-Air Full IAQ (Air Measuring Station)

TEK-Air Full IAQ can be set for two control types:

1. Fixed Minimum
2. Demand Ventilation



LD21615

**FIGURE 51 - TEK-AIR PROBE AND TRANSDUCER**



LD21616

**FIGURE 52 - TEK-AIR MONITOR****TEK-Air Factory Set-Up**

The TEK-Air station should come from the factory programmed for proper operation. The programming should be checked during start-up to ensure proper operation

- Password: 1234

**TABLE 37 - TEK-AIR MONITOR SETTINGS**

SETTING	VALUE
Area of Flow Device	18.0 ft <sup>2</sup>
Sensor Flow Coefficient	0.762
Altitude	0 ft
Analog Out Flow FS	24,000 cfm
Pressure Average Int	10 sec
Use Fan Interlock	Yes
Auto = Zero Interval	30 minutes
Enclosure Temp Setpoint	125.0 °F
Transducer Zero	0.00 "W.C.
Transducer FS	0.25 "W.C.

**TEK-Air Diagnostic Alarms**

The TEK-Air station also has some built in diagnostic alarms.

The diagnostic alarms are used to provide diagnostic information on the performance of the product and to alert the user to possible malfunction. The following are descriptions of the diagnostic alarms that are available at the IAQ-TEK monitor.

**Low Flow Alarm** – The Low Flow Alarm is used to alert the building operators that the intake volume has fallen below the minimum acceptable level. The control compares the derived CFM value to the programmed "*LOW FLOW ALARM*" setpoint. The unit is shipped from the factory with a "*LOW FLOW ALARM*" setpoint of 0 cfm. Should the airflow remain below this value for longer than the programmed Alarm Delay Period of 20 seconds, the IAQ-TEK monitor will show a Low Flow Alarm. To reset to normal, the air volume must rise to a value that is 10% higher than the "*LOW FLOW ALARM*" setpoint. Once this threshold has been crossed, the alarm is reset automatically.

**Reverse Flow Alarm** – This is used to identify that the airflow is blowing out of the intake of the outdoor air. Should the airflow remain reversed for longer than the programmed Alarm Delay Period of 20 seconds, the IAQ-TEK monitor will show a Reverse Flow Alarm. In order to reset, the pressure input from the probe to the transducer must increase to zero or have a sign change to positive. Once the value has changed, the alarm is reset automatically.

**Pressure Loss Alarm** – The signal from the pressure transducer to the monitor indicates a negative pressure. The alarm will be initiated immediately without a delay period.

**Outdoor Air Temperature Sensor Loss Alarm** – Indicates the Outside Air Temperature input to the monitor went either high (input short) or low (input open). The alarm will be initiated immediately without a delay period.

**Enclosure Temperature Loss Alarm** – Indicates the Enclosure Temperature input to the monitor from the transducer went high (input short) or low (input open). The alarm will be initiated immediately without a delay period.

**Loss of Enclosure Heater** – Indicates the enclosure temperature fell 11.0 °F below the "ENCL TEMP" setpoint. Should this remain low for longer than programmed Alarm Delay Period of 20 seconds, the IAQ-TEK monitor will show a Loss of Enclosure Heater Alarm. If the temperature remains below for 1 hour, a heater malfunction will be initiated.

**Auto-Zero Valve Malfunction** – Indicates the pressure transducer's auto-zero valve malfunction. The alarm will be initiated immediately without a delay period.

**Memory Loss Alarm** – Indicates there has been a loss of nonvolatile memory parameters. The alarm will be initiated immediately without a delay period.

**Checksum Error Alarm** – Indicates there is a memory checksum error. The alarm will be initiated immediately without a delay period.

### **TEK-Air w/ Fixed Minimum**

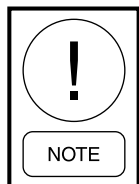
The Series 100 unit will modulate the O/A dampers to maintain a set amount of OA CFMs.

#### **Fixed Minimum**

- Ventilation system MUST be USER ENABLED
- Damper Hardware MUST be set for TEK-AIR FULL IAQ
- Ventilation control MUST be set for FIXED MINIMUM
- "MINIMUM FLOW OA" setpoint MUST be programmed

#### **TEK-Air w/ Fixed Minimum Sequence of Operation**

- Supply fan is ON
- Ventilation system is ACTIVE
- Economizer is INACTIVE



*If the economizer becomes active, the economizer control logic can open the O/A dampers past the "ACTIVE VENTILATION MINIMUM POSITION" setpoint. The economizer cannot close the O/A dampers below the "ACTIVE VENTILATION MINIMUM POSITION" setpoint.*

- Based on the programmed value for "MINIMUM FLOW OA" setpoint, the O/A dampers will modulate open/closed to maintain the required amount of OA CFMs

### **TEK-Air w/ Demand Ventilation**

- The Series 100 unit will modulate the O/A dampers to maintain a set amount of OA CFMs
- If ventilation demand rises, the O/A dampers will modulate between the "MINIMUM FLOW OA" setpoint and the "MAXIMUM FLOW OA" setpoint

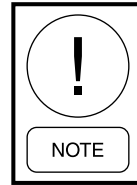
#### **Demand Ventilation**

- Ventilation system MUST be USER ENABLED
- Damper hardware MUST be set for TEK-AIR FULL IAQ

- Ventilation control MUST be set for DEMAND VENTILATION
- "MINIMUM FLOW OA" and "MAXIMUM FLOW OA" setpoints MUST be programmed

#### **TEK-Air w/ Demand Ventilation Sequence of Operation**

- Supply Fan is ON
- Ventilation system is ACTIVE
- Economizer is INACTIVE



*If the economizer becomes active, the economizer control logic can open the O/A dampers past the "ACTIVE VENTILATION MINIMUM POSITION" setpoint. The economizer cannot close the O/A dampers below the "ACTIVE VENTILATION MINIMUM POSITION" setpoint.*

- Based on the programmed value for "MAXIMUM FLOW OA", the O/A dampers will modulate open/closed to maintain the required amount of OA CFMs
- If the ventilation demand starts to rise, the O/A dampers will modulate between the "MINIMUM FLOW OA" and "MAXIMUM FLOW OA" setpoints until the ventilation demand decreases to 0%

#### **Continuous Ventilation**

- This sequence is only applicable for CV and SZ-VAV configured units only
- If Continuous Ventilation is set to USER ENABLED, the supply fan will be ON whenever the unit is in the OCC mode, regardless if there is a demand for cooling or heating
- If Continuous Ventilation is set to USER DISABLED, the supply fan will be OFF unless there is a demand for cooling or heating

#### **Comfort Ventilation**

- This sequence is applicable for CV and SZVAV configured units only
- This sequence prevents the interior space from becoming too warm/cool before a thermostat or zone temp sensor sends a demand for cooling or heating
- Typically used for CV and SZVAV units that have a large OA requirement

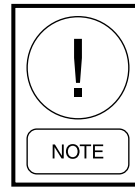
### Sequence of Operation

- The unit **MUST** have heat installed and it **MUST** be **USER ENABLED**
- Comfort Ventilation **MUST** be **USER ENABLED** (PROGRAM key / VENTILATION subsection)
- Unit **MUST** be in an OCC mode
- Comfort Vent Cool
  - Current SAT is greater than the "OCC ZONE COOLING" setpoint by 5.0 °F
  - Unit will enter Occ Cooling Low
  - Comfort Vent Cool will terminate once the current SAT is 5.0 °F less than the "OCC ZONE COOLING" setpoint for 5 minutes
- Comfort Vent Heat
  - Current SAT is less than the "OCC ZONE HEATING" setpoint by 5.0 °F
  - Unit will enter Occ Heating Low
  - Comfort Vent Heat will terminate once the current SAT is 5.0 °F greater than the "OCC ZONE HEATING" setpoint for 5 minutes

### EXHAUST FAN/RETURN FAN SYSTEM

The Series 100, 50-65 ton unit has the option of having either an exhaust fan or a return fan, but not both. The return fan can either be selected as return fan without exhaust or return fan with exhaust.

- The exhaust fan options are only used for assisting in controlling building pressure
- The return fan is used to ensure the proper amount of return air is brought back to the unit. They are typically only needed when return duct statics will be in excess of 0.75 "W.C.
  1. **Return fan without exhaust:** No exhaust damper installed. Cannot assist in controlling building pressure.
  2. **Return fan with exhaust:** Modulating exhaust damper installed. Assists in controlling building pressure.



**An exhaust fan system will have two blower wheels controlled by one motor. The motor may or may not be connected to a VFD.**

A return fan system will have two separate blower assemblies, each having their own wheel and motor. Both return fan motors will be controlled by one VFD. The return fan wheels will be rotating in opposite directions when operating properly.

### Exhaust Fan/Return Fan Proving Switch

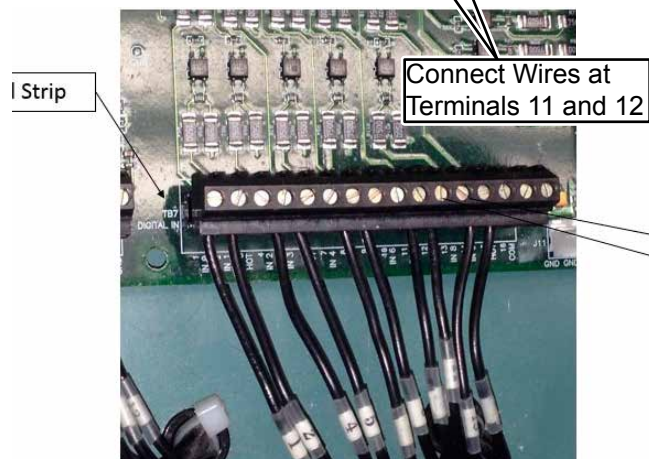
When the Series 100, 50-65 ton unit was originally designed, it did not include an exhaust/return fan proving circuit. This turned out to be an issue in the field because the exhaust/return fan proving circuit status was always shown as RUNNING even when the fans were OFF. There was a jumper wire installed on the I/O boards where the proving circuit would normally land.

To correct this issue, we added an option in the software so the unit controller can be told that the proving kit is either INSTALLED or NOT INSTALLED.

- If the NOT INSTALLED option is selected, the exhaust/return fan proving circuit will always

TB7 Terminal Strip RUNNING

- If the INSTALLED option is selected, control wiring must be installed between the unit I/O board and the exhaust/return fan VFD.



LD21617

**FIGURE 53 - TB7 TERMINAL STRIP**

- Connect the wires on the Relay 2 connection on the bottom of the VFD. Plug should be provided. Wires connect to Terminals 4 and 5.

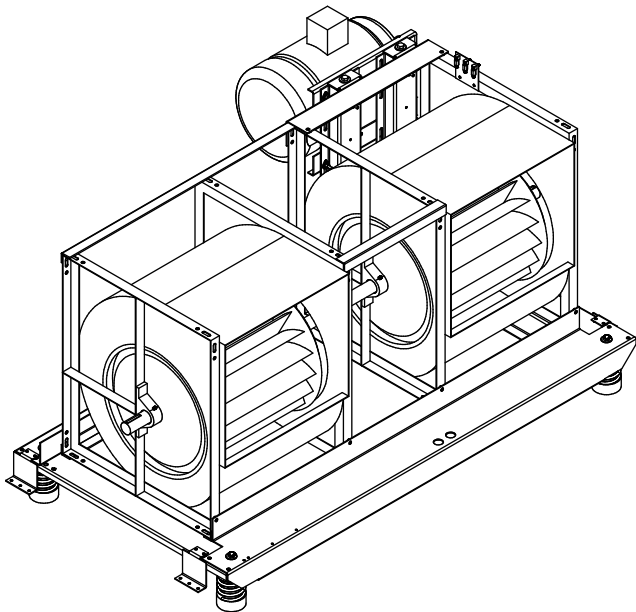




LD21618

RELAY PART NUMBERS	
130B1068	3 Wire Connector labeled 1-2-3
130B1069	3 Wire Connector labeled 4-5-6

**FIGURE 54 - RELAY 2**



LD14365

**FIGURE 55 - EXHAUST FAN ASSEMBLY**

## Exhaust Fan

### Exhaust System Options

- On/Off control based on damper position (CV only) (single speed exhaust fan, modulating damper)
- On/Off control based on building pressure (single speed exhaust fan, barometric damper)

- Modulating damper with fixed speed exhaust (single speed exhaust fan)
- Modulating exhaust fan with VFD (barometric exhaust damper)

### On/Off Based on Damper Position

- *"POWER EXHAUST TYPE"* MUST be set to ON-OFF DAMPER CONTROL
- *"ECONO OUTPUT FOR FAN START"* MUST be programmed into Unit Controller
- *"ECONO OUTPUT FOR FAN STOP"* MUST be programmed into Unit Controller

### Sequence of Operation: On/Off Based on Damper Position

- Only available on CV units
- When O/A damper position is greater than/equal to *"ECONO OUTPUT FOR FAN START,"* exhaust fan will start
- When O/A damper position is less than/equal to *"ECONO OUTPUT FOR FAN STOP,"* exhaust fan will stop

### On/Off Based on Building Pressure

- *"POWER EXHAUST TYPE"* MUST be set to ON-OFF PRESS CONTROL
- *"BUILDING PRESSURE ACTIVE"* setpoint MUST be programmed into Unit Controller
- *"BUILDING PRESS CNTRL OFFSET"* MUST be programmed into Unit Controller

### Sequence of Operation: On/Off Based on Building Pressure

- Building static pressure is greater than/equal to the *"BUILDING PRESS"* setpoint plus the *"BUILDING PRESS CNTRL OFFSET,"* the exhaust fan will start
- Building static pressure is less than/equal to the *"BUILDING PRESS"* setpoint minus the *"BUILDING PRESS CNTRL OFFSET,"* the exhaust fan will stop

**Modulating Damper with Fixed Speed Exhaust**

- *"POWER EXHAUST TYPE"* MUST be set to MODULATED DAMPER–VFD
- *"BUILDING PRESS"* setpoint MUST be programmed into Unit Controller
- *"EXHAUST OUTPUT FOR FAN START"* MUST be programmed into Unit Controller
- *"EXHAUST OUTPUT FOR FAN STOP"* MUST be programmed into Unit Controller

**Sequence of Operation: Modulating Damper w/ Fixed Speed Exhaust**

- Building pressure rises above the *"BUILDING PRESS"* setpoint
- Unit Controller sends a 0–10 VDC signal to exhaust damper actuator. Unit Controller will display this signal as a %. 0 VDC = 0% and 10 VDC = 100% (% output is displayed as EXHAUST DAMPER POSITION)
- When the % output is equal to/greater than the *"EXHAUST OUTPUT FOR FAN START,"* the exhaust fan will start
- When the % output is equal to/less than the *"EXHAUST OUTPUT FOR FAN STOP,"* the exhaust fan will stop

**Modulating Exhaust with VFD**

- *"POWER EXHAUST TYPE"* MUST be set to MODULATED DAMPER–VFD
- *"BUILDING PRESS"* setpoint MUST be programmed into Unit Controller
- *"EXHAUST OUTPUT FOR FAN START"* MUST be programmed into Unit Controller
- *"EXHAUST OUTPUT FOR FAN STOP"* MUST be programmed into Unit Controller

**Sequence of Operation: Modulating Exhaust with VFD**

- This option operates basically the same as Modulating Damper w/ Fixed Speed Exhaust. The 0–10 VDC signal is sent to the exhaust fan VFD instead of to the exhaust damper actuator
- Building pressure rises above the *"BUILDING PRESS"* setpoint

- Unit Controller sends a 0–10 VDC signal to exhaust fan VFD. Unit Controller will display this signal as a %. 0 VDC = 0% and 10 VDC = 100% (% output is displayed as EXHAUST DAMPER POSITION)
- When the % output is equal to/greater than the *"EXHAUST OUTPUT FOR FAN START,"* the exhaust fan will start
- When the % output is equal to/less than the *"EXHAUST OUTPUT FOR FAN STOP,"* the exhaust fan will stop
- Exhaust fan VFD speed will be controlled by the 0–10 VDC signal that is being sent by the Unit Controller

**Exhaust Fan Control: BAS**

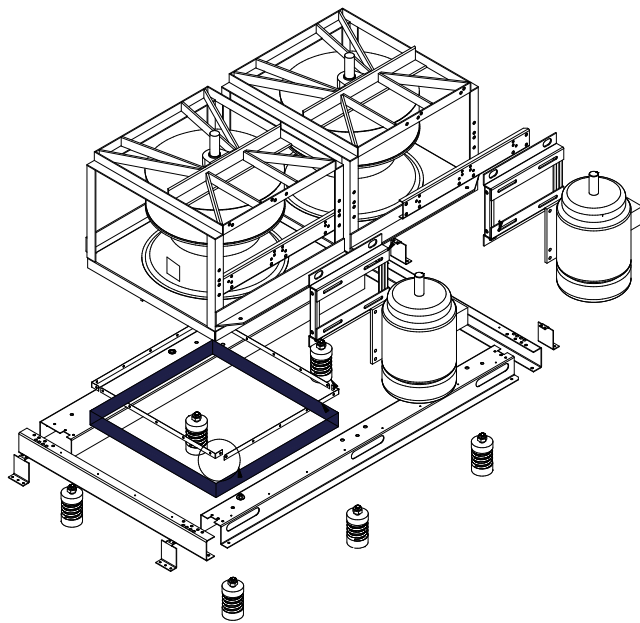
The Series 100, 50-65 ton unit has the ability to control the exhaust fan from a BAS. This will allow controls companies to control the exhaust fans of numerous units at the same speed.

**Sequence of Operation**

- *"POWER EXHAUST TYPE"* MUST be set to MODULATED DAMPER–VFD
- *"EXHAUST CONTROL BAS"* must be USER ENABLED. This will be done with the SERVICE key
- The BAS will send a 0–100 % signal to the Unit Controller
- When the command equals the *"EXHAUST OUTPUT FOR FAN START"* setpoint, the VFD will ramp to min speed
- The VFD will ramp up/down according to the BAS command
- When the command drops below the *"EXHAUST OUTPUT FOR FAN STOP"* setpoint, the VFD will stop the motor

**Return Fan**

A Series 100 unit can be ordered with a return fan. A return fan is typically used on an HVAC system that has higher than normal return duct static. The return fan will assist the supply fan in making sure that proper return air flow is maintained. Return fans will be controlled by a VFD, and will operate whenever the supply fan is operating



LD14363

**FIGURE 56 - RETURN FAN ASSEMBLY**

### Return Fan Options

- Return Fan without Exhaust
  - This selection will have no building pressure control
- Return Fan with Exhaust
  - This selection will have modulating exhaust dampers and will have building pressure control

### Return Fan without Exhaust

*"POWER EXHAUST TYPE"* MUST be set to RETURN FAN W/O EXHAUST

### Sequence of Operation: Return Fan without Exhaust

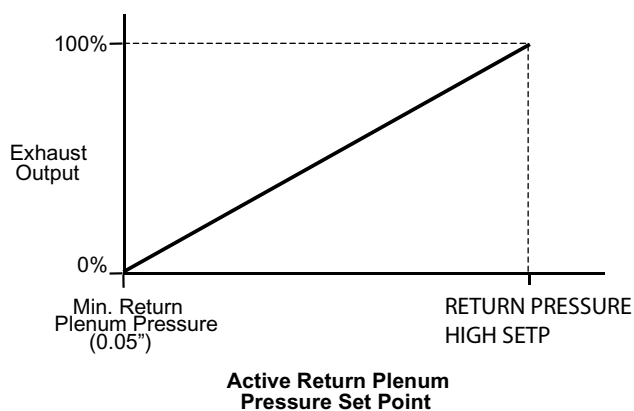
- Supply fan starts, air proving switch closes
- Return fan starts
- The return fan plenum pressure transducer measures the pressure of the return fan plenum
- Based on the return fan plenum pressure, the Unit Controller will send a 0–10 VDC signal to the return fan VFD
- The return fan VFD will control the speed of the return fan to maintain the *"ACTIVE RETURN PLENUM PRESS"* setpoint (this setpoint is fixed at 0.05 "W.C. for a return fan without exhaust)

### Return Fan with Exhaust

- *"POWER EXHAUST TYPE"* MUST be set to RETURN FAN W EXHAUST
- *"BUILDING PRESS"* setpoint MUST be programmed into Unit Controller
- *"RETURN PRESSURE HIGH"* setpoint MUST be programmed into Unit Controller

### Sequence of Operation: Return Fan with Exhaust

- Supply fan starts, air proving switch closes
- Return fan starts
- Building pressure below *"BUILDING PRESS"* setpoint (return fan will control like a Return Fan without Exhaust)
  - The return fan plenum pressure transducer measures the pressure of the return fan plenum
  - Based on the return fan plenum pressure, the Unit Controller will send a 0–10 VDC signal to the return fan VFD
  - The return fan VFD will control the speed of the return fan to maintain the *"ACTIVE RETURN PLENUM PRESS"* setpoint (this setpoint is fixed at 0.05 "W.C.)
- Building pressure equal to/greater than *"BUILDING PRESS"* setpoint
  - Once the building pressure equals or rises above the *"BUILDING PRESS"* setpoint, the Unit Controller sends a 0–10 VDC signal to the exhaust damper actuator. The Unit Controller displays this signal as a % and can be seen as the EXHAUST DAMPER POSITION. (0 VDC = 0% and 10 VDC = 100%)
  - As the exhaust damper position increases, the speed of the return fan will be controlled by the Return Fan Plenum Pressure Control Loop. The *ACTIVE RETURN PLENUM PRESS* setpoint will be reset between the *"MINIMUM RETURN PLENUM PRESS"* setpoint (non-adjustable 0.05 "W.C.) and the *"RETURN PRESSURE HIGH"* setpoint (user adjustable between 0.15 "W.C. and 0.45 "W.C.)
  - Once the building pressure drops below the *"BUILDING PRESS"* setpoint, the return fan will again be controlled like a Return Fan without Exhaust



**FIGURE 57 - ACTIVE RETURN PLENUM PRESSURE SETPOINT VS. EXHAUST OUTPUT**

LD10153A

## FLEXSYS OPERATION

The following sections deal with the operation of a Series 100 unit configured for Flexsys operation. Flexsys operation is the use of an underfloor plenum to provide conditioned air to a building. Since the conditioned air is delivered up from the floor, the operation differs from that of a typical VAV system. Please review these sections thoroughly before proceeding with unit set-up, start-up, and operation.

The design of a Flexsys system is very critical to the proper operation of the Series 100 unit. Please review the following areas that create issues with the proper operation of a Flexsys system/unit.

- **Plenum Integrity:** “If you make a hole, seal a hole.” The underfloor plenum must be completely sealed from air leaking out.
- **Open Plenum Returns:** It is highly recommended that returns be ducted to every room. This allows the warmer return air to properly mix and be at the proper temperature returning to the unit.
- **Six-Foot Cooling Zone:** When designing a Flexsys system, only the first 6 feet from the floor up is to be conditioned. Above 6 feet, the air needs to be mixed with heat loads. This will ensure that the R/A is at least 78.0 °F. It has been determined that RATs cooler than 78.0 °F cannot properly raise the temperature of the air leaving the evaporator coil to the recommended MX SAT of 62.0–64.0 °F. It has been determined that MX SATs lower than 62.0 °F are uncomfortable to occupants of a space.

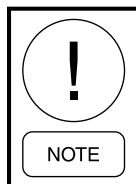
- **Multiple Plenums/One Unit:** When designing a system that will serve multiple plenums, it is highly recommended that each plenum have its own volume damper controlled by an actuator. Each plenum should also have its own pressure transducer that controls the actuator driven volume damper. Each plenum should be maintained at 0.05 ”W.C.

The above issues should have been taken into consideration during the design and engineering phase of the project.

Since a Flexsys unit delivers air through an underfloor plenum, some of the setpoints differ from a typical VAV unit. Below are recommended setpoints provided by the Engineering Team. There has been a lot of testing and research done on these systems to arrive at these setpoints. Please be advised that these are recommendations only, and job specific setpoints could be different. We recommend using these setpoints at least as a starting point.

## Factory Recommended Setpoints

- “*RAT COOLING*” setpoint: 78.0 °F
- “*MX SAT*” setpoint: 62.0–64.0 °F (see note)
- “*EVAP LEAVING AIR TEMP HIGH*” setpoint: 58.0 °F
- “*EVAP LEAVING AIR TEMP LOW*” setpoint: 55.0 °F
- “*DUCT STATIC*” setpoint: 0.05 ”W.C.
- “*HEATING SAT*” setpoint: 80.0 °F
- “*MAX BYPASS*”: 40%



***On a Flexsys unit, the MX SAT is the temperature of the supply air off the evaporator coil mixed with the warmer return air that is bypassed around the evaporator coil. The bypassed return air is introduced directly under the supply air fan.***

## Flexsys: Current Operating Mode (Occupied)

The Current Operating mode for a Flexsys configured unit will be decided the same as for a VAV configured unit: by the return air temperature.

- If the RAT is  $\geq$  the “*COOLING RAT*” setpoint by 0.5 °F, the unit will enter the Cooling mode

- If the RAT  $\leq$  the "HEATING RAT" setpoint by 0.5°F, the unit will enter the Heating mode
- If the RAT is between the "COOLING RAT" setpoint and the "HEATING RAT" setpoint, the unit will remain in the Standby mode

### Flexsys: Fan Operation

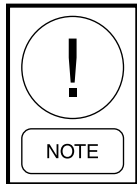
The same as a VAV configured unit, the supply fan will be controlled by a VFD. The VFD will control the speed of the supply fan up/down to achieve and maintain the "ACTIVE DUCT STATIC" setpoint

Also the same as a VAV configured unit, the supply fan will be on whenever the unit is in the OCC mode, and will cycle on/off in the UNOCC mode with a demand for heating or cooling

### Flexsys: Cooling

#### Occupied

Whenever a Flexsys unit enters an Occ Cooling mode, it will always start in the Occ Cooling w/o Bypass mode for the first 30 seconds. After this time delay has expired, the Unit Controller will determine which mode it needs to be in: Occ Cooling w/o Bypass or Occ Cooling w/ Bypass



***The programmable option, SAT RESET, is not utilized on Flexsys configured units. If the need arises to reset the "MX SAT" setpoint on a Flexsys configured unit, it will need to be done through the BAS.***

#### Occ Cooling w/o Bypass

The Unit Controller will cycle the compressors or modulate the O/A damper to achieve and maintain the "MX SAT" setpoint.

- If the economizer is active, the unit will remain in the Occ Cooling w/o Bypass mode
- OR
- If the RAT  $\geq$  "RAT" setpoint plus 0.5 °F BUT RAT  $<$  "MX SAT" setpoint + the "RA DIFF" setpoint (user adjustable between 2.0–10.0 °F)

#### Occ Cooling w/ Bypass

If the RAT  $\geq$  "RAT" setpoint plus 0.5 °F AND RAT  $>$  "MX SAT" setpoint + the "RA DIFF" setpoint (user adjustable between 2.0–10.0 °F)

The Unit Controller will cycle the compressors to maintain either the "EVAP LEAVING AIR TEMP HIGH" setpoint or the "EVAP LEAVING AIR TEMP LOW" setpoint.

The Unit Controller will modulate the Flexsys bypass damper open/closed to achieve and maintain the "MX SAT" setpoint.

- "EVAP LEAVING AIR TEMP HIGH" setpoint
    - R/A humidity sensor is not reliable
- OR
- R/A enthalpy  $<$  the "RESET ENTHALPY" setpoint
- "EVAP LEAVING AIR TEMP LOW" setpoint
    - R/A enthalpy is  $\geq$  "RESET ENTHALPY" setpoint
- OR
- Underfloor slab dewpoint is  $\geq$  underfloor slab temperature – 2.0 °F for 120 seconds (only if dew point reset is USER ENABLED)

### Return Air Bypass

**Current %:** This is the amount of air the Unit Controller believes it is bypassing due to the fact that the MX SAT is not increasing. The Unit Controller utilizes the current RAT, the current evaporator leaving air temperature, and the MX SAT to perform a calculation to arrive at the Current %.

**Active SP %:** This is how much of the return air the Unit Controller believes it needs to bypass to warm the "MX SAT" setpoint from its current value to the "MX SAT" setpoint. The Unit Controller utilizes the current RAT, the current evaporator leaving air temperature, and the current MX SAT to perform a calculation to arrive at the Active SP %

Both of the above numbers are based on internal algorithms and logic built into the Unit Controller. The algorithms and internal logic are not user adjustable.

### Bypass Damper Position

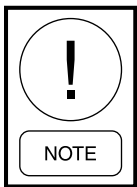
This is the actual position of the bypass damper. The bypass damper should be able to drive between 0% and 40%.

## Bypass Damper Operation

The operation of the bypass damper is very slow, and the logic that drives the damper is quite complicated. When the unit is in normal operation, it could take up to 30 minutes for the bypass damper to go from 0% to 40%. If the unit is operating properly and the temperatures are in the proper range, the damper will probably never drive to 40%.

### Max Bypass

This is the maximum amount of return air that the Unit Controller will allow to bypass around the evaporator coil through the Flexsys bypass damper. The Unit Controller will utilize internal logic and calculations to determine how much of the return air is being bypassed. This is not the same as the actual bypass damper position. This is an adjustable setpoint with a range of 20–40%. We recommend leaving it at 40% for initial start-up and then adjusting down later if needed.



***It is very likely that the parameters mentioned above—"RETURN AIR BYPASS CURRENT %," "RETURN AIR BYPASS ACTIVE SP %," and "BYPASS DAMPER POSITION %" will not have matching values. This is normal; do not be alarmed.***

### Unoccupied

Unoccupied Cooling mode will be initiated by the current zone temperature being higher than the "*UNOCCUPIED ZONE COOLING*" setpoint by 0.5 °F. The "*NIGHT SET BACK*" feature must be USER ENABLED. "*NIGHT SET BACK*" can be found under the PROGRAM key / HEATING subsection.

- Supply fan starts. Supply fan VFD is controlled to the "*ACTIVE DUCT STATIC*" setpoint
  - O/A damper is modulated open/closed to achieve and maintain the "*MX SAT*" setpoint
- AND/OR
- Compressors are cycled on/off to achieve and maintain the "*MX SAT*" setpoint
  - Bypass damper remains closed
  - Cooling operation will continue until the current zone temperature is less than the "*UNOCC ZONE COOLING*" setpoint by 0.5 °F

## Flexsys: Compressor Control

### Occupied Cooling w/o Bypass

- Series 100 enters an Active Cooling mode
- Unit Controller sets the "*COOLING CONTROL OFFSET*" to 2.0 °F
- Unit Controller compares the current MX SAT to the "*MX SAT*" setpoint  $\pm$  the "*COOLING CONTROL OFFSET*"
- If MX SAT is greater than the "*MX SAT*" setpoint plus the "*COOLING CONTROL OFFSET*," the Unit Controller will:
  - Start a compressor

OR

  - Bring on an additional stage of cooling based on the NEXT STAGE TO ENABLE
- If MX SAT is less than the "*MX SAT*" setpoint minus the "*COOLING CONTROL OFFSET*," the Unit Controller will stop a compressor based on the NEXT STAGE TO DISABLE

### Occupied Cooling w/ Bypass

- Series 100 unit enters an Active Cooling mode
- Unit Controller sets the "*COOLING CONTROL OFFSET*" to 2.0 °F
- Unit Controller compares the evaporator leaving air temperature to the "*ACTIVE EVAP LEAVING AIR TEMP*" setpoint  $\pm$  the "*COOLING CONTROL OFFSET*"
- If evaporator leaving air temperature is greater than the "*ACTIVE EVAP LEAVING AIR TEMP*" setpoint plus the "*COOLING CONTROL OFFSET*," the Unit Controller will:
  - Start a compressor

OR

  - Bring on an additional stage of cooling based on the NEXT STAGE TO ENABLE
- If the evaporator leaving air temperature is less than the "*ACTIVE EVAP LEAVING AIR TEMP*" setpoint, the Unit Controller will stop a compressor based on the NEXT STAGE TO DISABLE

### Flexsys: Heating

OCC/UNOCC heating operation will follow the same sequence as a VAV configured unit, unless UNDER FLR TEMP OVRD is ACTIVE (see below).

It is recommended to limit the "HEATING SAT" setpoint to 80.0 or 90.0 °F. This will prevent the underfloor concrete slab from becoming too warm and then radiating heat for an extended period of time after heating operation has been terminated.

### UnderFloor Temp Override

If UNDER FLR TEMP OVRD is ACTIVE, the Unit Controller will stage the heating systems to try and maintain the "UNDERFLOOR TEMP CONTROL" setpoint instead of the "HEATING SAT" setpoint.

### Flexsys: Underfloor Temperature Control

#### Dew Point Reset

This sequence changes the Active evaporator leaving air temperature to a lower value when the temperature of the underfloor air approaches its dew point.

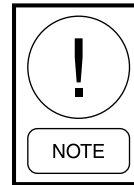
- MUST have an underfloor slab temperature sensor AND an underfloor humidity sensor installed (field provided and field wired to CTB1; can also be communicated from the BAS)
- Dew Point Reset MUST be USER ENABLED
- Unit Controller uses the MX SAT and the underfloor humidity to calculate the underfloor dew point
- If underfloor air dew point  $\geq$  the underfloor slab temperature – 2.0 °F for 120 seconds, the Unit Controller will switch from the "EVAP LEAVING AIR TEMP HIGH" setpoint to the "EVAP LEAVING AIR TEMP LOW" setpoint
- Unit Controller will continue to use the "EVAP LEAVING AIR TEMP LOW" setpoint until the underfloor air dew point < the underfloor slab temperature – 2.5 °F

#### Active Slab Control

This sequence allows heat to be turned ON during a transition from one occupancy state to another if the underfloor air temperature is higher than the underfloor slab temperature.

- Unit MUST have heat installed
- Heating system MUST be USER ENABLED

- Active Slab Control MUST be USER ENABLED
- MUST have an underfloor slab temperature sensor installed (field provided and field wired to CTB1; can also be communicated from the BAS)



**The unit display shows the Heating System Status as INACTIVE while in Active Slab Control. The Supply System Status shows as ACTIVE.**

### Unoccupied to Occupied

- Unit Controller checks the underfloor slab temperature immediately after switching from "UNOCC STANDBY" to "OCC STANDBY" (if the Unit Controller calls from "OCC COOLING W/ BYPASS" or "OCC COOLING W/O BYPASS" during this time, Active Slab Control will be terminated)
- If underfloor slab temperature  $\leq$  the "MX SAT" setpoint – 2.0 °F, the UNDER FLR TEMP OVRD will become ACTIVE
- Underfloor Temp Control is set to "MX SAT" setpoint + 10.0 °F
- Unit Controller will generate a call for heat
  - If staged heat (staged gas or electric), Unit Controller will start the first stage of heat
  - If modulating (modulating gas or hot water/steam), Unit Controller will control the SAT to the "UNDERFLOOR TEMP CONTROL" setpoint
- Heating operation will continue until
  - The underfloor slab temperature  $\geq$  the MX SAT" setpoint

OR

  - 20 minutes time has elapsed

### Occupied to Unoccupied Mode

- Unit Controller checks the Underfloor Slab Temp immediately after switching from an Occupied mode to Unoccupied Standby
- If the underfloor slab temperature > the RAT – 2.0°F, UNDER FLR TEMP OVRD will become ACTIVE
- The "UNDERFLOOR TEMP CONTROL" setpoint is set to the "RAT" setpoint + 10.0 °F

- Unit Controller will generate a call for heat
  - If staged heat (staged gas or electric), Unit Controller will start the first stage of heat
  - If modulating (modulating gas or hot water/steam), Unit Controller will control the SAT to the "*UNDERFLOOR TEMP CONTROL*" setpoint
- Heating operation will continue until
  - The underfloor slab temperature  $> \text{RAT} + 1.0^{\circ}\text{F}$   
OR
  - 20 minutes time has elapsed

### Flexsys: All Other Sequences

The other sequences of operation for a Flexsys unit will follow the same procedures as a VAV configured unit.

### SMOKE PURGE

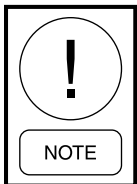
The Series 100 unit has the ability to enter into one of three smoke purge sequences. These sequences should only be used in very specific applications. While in Smoke Purge mode, all other functions and commands will be ignored.

#### Smoke Purge Sequences

1. Smoke Purge Sequence 1
2. Smoke Purge Sequence 2
3. Smoke Purge Sequence 3

Each of the above sequences can be set for one of three different control sequences:

1. Purge (Highest Priority)
2. Pressurization (Medium Priority)
3. Evacuation (Lowest Priority)



***On VAV and Flexsys units, the supply fan VFD will still control to the "ACTIVE DUCT STATIC" setpoint***

### Purge Mode

Sequence of Operation: Used to purge the space with fresh air.

- Start the supply fan
- Start the return fan (if applicable)
- Start the exhaust fan (if applicable)
- Open O/A dampers to 100% (if applicable)
- Close R/A dampers to 0% (if applicable)
- Open exhaust dampers to 100% (if applicable)

### Pressurization Mode

Sequence of Operation: Used to pressurize the space in order to force the air inside the space through the walls to adjacent spaces or outside the building envelope.

- Start the supply fan
- Start the return fan (if applicable)
- Stop the exhaust fan (if applicable)
- Open O/A dampers to 100% (if applicable)
- Close the R/A dampers to 0% (if applicable)

### Evacuation Mode

Sequence of Operation: Used to evacuate the space in order to draw air through the walls from adjacent spaces or outside the building envelope.

- Stop the supply fan
- Start the return fan (if applicable)
- Start the exhaust fan (if applicable)
- Close O/A dampers to 0% (if applicable)
- Open R/A dampers to 100% (if applicable)
- Open the exhaust dampers to 100% (if applicable)



## SECTION 6 – USER INTERFACE CONTROL CENTER

### USER INTERFACE CONTROL CENTER

The User Interface is used to commission, monitor, and troubleshoot the rooftop unit. It provides access to operational data, parameter programming, and access to past “history” information that was recorded at the time of a unit or system fault.

The User Interface is installed in the low voltage control compartment of the rooftop unit.

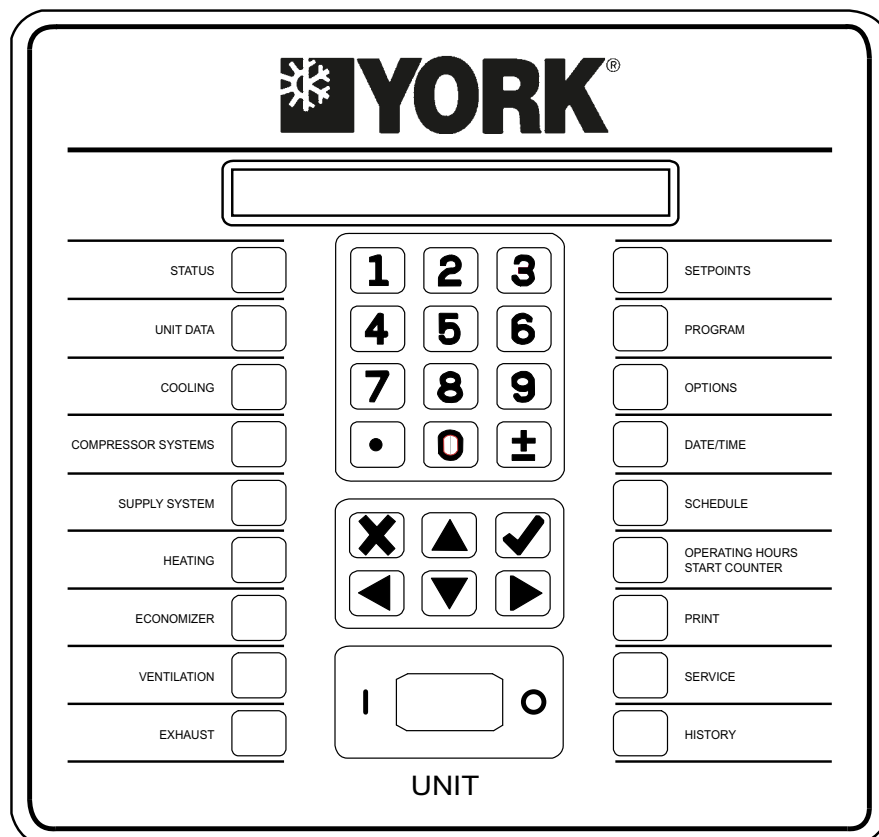
The User Interface uses a flexible membrane style keypad and has an 80 character (2 lines of 40 characters) liquid crystal display. The display has a lighted background for night viewing and can be viewed in direct sunlight. The backlighting will energize when any button is pressed.

The keypad allows complete control of the system from a central location. The keypad offers a multitude of commands available to access displays, program pa-

rameters, and initiate system commands. The keypad consists of thirty-six keys, that are divided into three categories, Data Entry, Navigation, and Menu Selection keys. A description of each of the keys is contained below.

### Data Entry Keys

The Data Entry Keys provide a means to enter values for items that support edits. The keys available to support numeric input are the 0 through 9 keys, the decimal key, the +/- key, the **X** key and the ✓ key. The keys available to support choice input are the ◀ key, the ▶ key, the **X** key, and the ✓ key. Editing is started by pressing the ✓ key. **Once editing has started, the user must press either the ✓ key or the X key.** Any other key press will result in the “Press ✓ or X to Exit” message displayed for two seconds. If you try to edit an item that is view only it will be ignored by the menu system.



LD010669

FIGURE 58 - USER INTERFACE CONTROL PANEL

When a numeric value that can be modified is displayed, the Default, High, and Low prompt will be shown in the upper right portion of the display. The cursor will be shown at the digit to be changed. The cursor will be shown after editing has started. After the desired numeric value has been entered, press the ✓ key to save the new value and exit the edit mode. Pressing the ◀ key will fill in the default value. Edits will only be accepted when followed by pressing the ✓ key. Pressing the ✕ key while in the edit mode will cancel the edit mode and leave the value unchanged. If an out of range value is entered, the Default, High and Low prompt is replaced by the “Out of Range” message for two seconds.

When a choice value that can be modified is displayed, the ◀ ▶ prompt will be shown in the upper right portion of the display. The cursor will be shown after editing has been started. The ◀ key or the ▶ key will allow the different choices to be viewed. When the desired choice is displayed, press the ✓ key to save the new value and exit the edit mode. Pressing the ✕ key while in the edit mode will cancel the edit mode and leave the value unchanged.

### Navigation Keys

The Navigation Keys provide a means to browse items within a menu. The keys currently available to support navigation are the Menu Select keys, the ▲ key, the ▼ key, the ◀ key, and the ▶ key.

Pressing a Menu Select key brings the user to the first screen under that menu. The screens within each menu are arranged in a circular list. The user may browse through the screens using the ▲ key and the ▼ key. Pressing the ▼ key will advance through the screens in order from top to bottom until the bottom screen has been reached. When the bottom screen is displayed, pressing the ▼ key will wrap the display to the top screen of the menu. Pressing the ▲ key will move through the screens in order from bottom to top until the top screen has been reached. When top screen is displayed, pressing the ▲ key will wrap the display to the bottom screen of the menu. Once either the ▲ key or the key ▼ is pressed, pressing any Menu Select key will bring the user to the first screen under that menu (even if it is the same menu being viewed).

Navigation through the circular list of items can also be achieved by repeated presses of the same Menu Select key, as long as no other keys are pressed. For example, pressing the UNIT DATA key three times will bring the user to the third screen of the UNIT DATA menu; pressing the UNIT DATA key once, then pressing the ▼ key, then pressing the Unit Data key again will bring the user to the first screen of the UNIT DATA menu.

The ◀ key and the ▶ key are used to scroll “sideways” between the same displays for each system. For example, when viewing the Sys 1 Pressures under the COMPRESSOR SYSTEMS key, pressing the ▶ key will scroll “sideways” to the Sys 2 Pressures display and pressing the ◀ key will scroll “sideways” to the Sys Pressures display for the last system on the unit.

When programming numeric or non-numeric values, the ▼ key and the ▲ key are used to scroll forward (down) and backward (up) through the items to be programmed or set.

### Menu Select Keys

The following menu keys are available on the User Interface; Status, Unit Data, Cooling, Compressor Systems, Supply System, Heating, Economizer, Ventilation, Exhaust, Setpoints, Program, Options, Date/Time, Schedule, Operating Hours / Start Counter, Print, Service, and History.

Each of the above menu keys gives access to a list of specific items contained in that menu. To minimize clutter, only the items applicable to the current unit configuration will be displayed. Pressing any of the menu select keys at any time will send the user to the first item of the associated menu, provided the user is not editing an item in the current menu key item or the menu key is being used to navigate through a list of items.

*Table 41 on page 123* list the information that is contained under the Status, Unit Data, Cooling, Compressor Systems, Supply System, Heating, Economizer, Ventilation, and Exhaust menu selection keys of the User Interface. The tables contain the Displayed Text, Pass Word Level (if applicable), Range of Values (if applicable), Default Value (if applicable), what key (Setpoints, Program, Options) to use to change the value (if applicable), and under what circumstances the item is displayed.

**TABLE 41 - STATUS**

DISPLAY TEXT	RANGE	DEFAULT	SETTING LOCATION	SHOWN WHEN
<b>UNIT - OVERALL STATUS</b>	Local stop / run / unit trip / unit fault / unit lockout / smk purge #-press / smk purge #-purge / smk purge #-evac	DERIVED		ALWAYS
<b>CURRENT OPER MODE</b>	Occ standby / occ cooling low / occ cooling high / occ heating low / occ heating high / unocc standby / unocc cooling low / unocc cooling high / unocc heating low / unocc heating high / morning warm-up / comfort vent cooling / comfort vent heating	DERIVED		Unit type equals CV or SZVAV
<b>CURRENT OPER MODE</b>	Occupied standby / occupied heating / occupied cooling / unoccupied standby / unoccupied heating / unoccupied cooling / morning warm-up	DERIVED		Unit type equals VAV
<b>CURRENT OPER MODE</b>	Occupied standby / occupied heating / occ cooling w/o byp / occ cooling w/ byp / unoccupied standby / under floor temp override	DERIVED		Unit type equals FLEXSYS
<b>SUPPLY SYS STATUS</b>	Normal - active / normal inactive / safety trip / safety FAULT / safety lockout	DERIVED		ALWAYS
<b>COMP SYS 1 STATUS</b>	Normal - comp a on / normal - comp b on / normal - both on / normal - both off / safety trip / safety FAULT / safety lockout / low amb inhibit / low suct temp unl / high dp unload / user disabled	DERIVED		ALWAYS
<b>COMP SYS 2 STATUS</b>	Normal - comp a on / normal - comp b on / normal - both on / normal - both off / safety trip / safety fault / safety lockout / low amb inhibit / low suct temp unl / high dp unload / user disabled	DERIVED		ALWAYS
<b>HEATING SYS STATUS</b>	Normal - active / normal - inactive / safety trip / safety fault / safety lockout / user disabled / none	DERIVED		ALWAYS
<b>ECONO SYS STATUS</b>	Normal - active / normal - inactive / safety trip / safety fault / safety lockout / user disabled / none	DERIVED		ALWAYS
<b>VENT SYS STATUS</b>	Normal - active / normal - inactive / safety trip / safety fault / safety lockout / user disabled / none	DERIVED		ALWAYS
<b>EXHAUST SYS STATUS</b>	Normal - active / normal - inactive / safety trip / safety fault / safety lockout / user disabled / none	DERIVED		ALWAYS
<b>SENSOR / MISC STATUS</b>	Normal / warning / safety trip / safety fault / safety lockout	DERIVED		ALWAYS
<b>FILTER STATUS</b>	Okay / change	DERIVED		ALWAYS

**TABLE 42 - UNIT DATA**

DISPLAY TEXT	PASS WORD LEVEL	RANGE	DEFAULT	SETTING LOCATION	SHOW WHEN UNIT TYPE IS:
UNIT TYPE	2	Constant Volume / Variable Air Volume / FlexSys / Single Zone Vav	Constant Volume	Options / Unit Data	Always
UNIT SIZE	2	50 Ton, 51 Ton, 60 Ton, 61 Ton,	50 Ton	Options / Unit Data	Always
REFRIGERANT TYPE	2	R22 / R407C / R-410A	R-410A	Options / Unit Data	Always
CONTROL METHOD	1	Staged / Wired Zone Temp / Comm Zone Temp	Staged	Options / Unit Data	Unit Type Equals Constant Volume or SZVAV
SAT RESET METHOD	1	Hardwired, Outside Air, Return Air, Supply Fan Speed	Hardwired Input	Options / Unit Data	Unit Type Equals Variable Air Volume or SZVAV
<b>SUPPLY AIR TEMP</b>					
CURRENT		-20.0 °F To 180.0°F	Look Up Table		Unit Type Equals Constant Volume, Variable Air Volume or SZVAV
ACTIVE SP		50.0 °F To 150.0 °F	Derived		
<b>MX SUPPLY AIR TEMP</b>					
CURRENT		-20.0 °F To 180.0 °F	Look Up Table		Unit Type E Equals FlexSys
SETPOINT	1	50.0 °F To 65.0 °F	65 °F	Setoints / Unit Data	
<b>ZONE TEMP*</b>					
CURRENT		-20.0 °F To 180.0 °F	Look Up Table		Unit Type Equals Constant Volume, Variable Air Volume or SZVAV
OCC ZONE COOLING SETPOINT	1	Occ Zone Heating Setpoint + 2.0 °F	72.0 °F	Setoints / Unit Data	
<b>ZONE TEMP*</b>					
CURRENT		-20.0 °F To 180.0 °F	Look Up Table		Unit Type Equals Constant Volume, Variable Air Volume or SZVAV
UNOCC ZONE COOLING SETPOINT	1	Unocc Zone Heating Setpoint + 2.0 °F To 95.0 °F	85.0 °F	Setpoints / Unit Data	
<b>ZONE TEMP*</b>					
CURRENT		-20.0° F To 180.0° F	Look Up Table		Unit Type Equals Constant Volume, Variable Air Volume or SZVAV
OCC ZONE HEATING SETPOINT	1	60° F To Occ Zone Cooling Setpoint - 2.0°F	68.0 °F	Setoints / Unit Data	
<b>ZONE TEMP*</b>					
CURRENT		-20.0 °F To 180.0 °F	Look Up Table		Unit Type Equals Constant Volume, Variable Air Volume or SZVAV
UNOCC ZONE HEATING SETPOINT	1	50° F To Unocc Zone Cooling Setpoint - 2.0 °F	60.0 °F	Setpoint / Unit Data	
SMOKE PURGE SEQ 1	1	Purge / Pressurization / Evacuation	Purge	Options / Unit Data	Always

**TABLE 42 - UNIT DATA (CONT'D)**

DISPLAY TEXT	PASS WORD LEVEL	RANGE	DEFAULT	SETTING LOCATION	SHOW WHEN UNIT TYPE IS:
<b>SMOKE PURGE SEQ 2</b>	1	Purge / Pressurization / Evacuation	Pressurization	Options / Unit Data	Always
<b>SMOKE PURGE SEQ 3</b>	1	Purge / Pressurization / Evacuation	Evacuation	Options / Unit Data	Always
<b>DISPLAY LANGUAGE</b>	1	English / Spanish	English	Options / Unit Data	Always
<b>DISPLAY UNITS</b>	1	Imperial / Metric	Imperial		Always

\* ONLY THE ZONE TEMP SCREEN FOR THE CURRENT ACTIVE MODE WILL BE SHOWN.

**TABLE 43 - COOLING**

DISPLAY TEXT	PASS WORD LEVEL	RANGE	DEFAULT	SETTING LOCATION	SHOW WHEN UNIT TYPE IS
<b>SUPPLY AIR TEMP</b>					
CURRENT		-20.0 °F To 180.0°F	Look up table		Unit Type Equals CONSTANT VOLUME or Variable AIR VOLUME or SZVAV
ACTIVE SP		50.0 °F To 150.0 °F	Derived		
<b>FLEX EVAP TEMP</b>					
CURRENT		-20.0 °F To 180.0 °F	Look up table		Unit Type Equals FLEXSYS and Current Oper Mode Is Occ Cooling W/ Byp
ACTIVE SP		50.0 °F To 60.0 °F	Derived		
<b>MX SUPPLY AIR TEMP</b>					
CURRENT		-20.0 °F To 180.0 °F	Look up table		Unit type equals FLEXSYS
SETPOINT	1	50.0 °F To 75.0 °F	65.0 °F	Setpoints/ Cooling	
COOLING CONTROL OFFSET		1.0 °F To 100.0 °F	Derived		
<b>ZONE TEMP*</b>					
CURRENT		-20.0 °F To 180.0 °F	Look up table		Unit Type Equals CONSTANT VOLUME or Variable AIR VOLUME or SZVAV
OCC ZONE COOLING SETPOINT	1	Occ Zone Heating + 2.0 °F To 85.0 °F	72.0 °F	Setpoints/ Cooling	
<b>ZONE TEMP*</b>					
CURRENT		-20.0 °F To 180.0 °F	Look up table		Unit Type Equals CONSTANT VOLUME or Variable AIR VOLUME or SZVAV
UNOCC ZONE COOLING SETPOINT	1	Unocc Zone Heating + 2.0 °F To 95.0 °F	85.0 °F	Setpoints/ Cooling	
<b>RETURN AIR TEMP</b>					
CURRENT		-20.0 °F To 180.0 °F	Look up table		Unit Type Equals Variable AIR VOLUM or FLEXSYS
RAT COOLING SETPOINT	1	Rat Heating Setp +2.0 °F To Rat For High Sat	70.0 °F	Setpoints/ Cooling	
<b>RETURN AIR BYPASS</b>					
CURRENT		0 To 100%	Derived		Unit type equals FLEXSYS
ACTIVE SP		0 To 100%	Derived		
BYPASS DAMPER POSITION		0 to 100%	Derived		Unit type equals FLEXSYS

**6**

**TABLE 43 - COOLING (CONT'D)**

DISPLAY TEXT	PASS WORD LEVEL	RANGE	DEFAULT	SETTING LOCATION	SHOW WHEN UNIT TYPE IS
<b>UNDERFLOOR AIR</b>					
TEMP		-20.0 °F To 180.0 °F	Look up table		Unit type equals FLEXSYS and dewpoint reset equals enabled
HUMIDITY		0 To 100%	Derived		
<b>UNDERFLOOR SLAB</b>					
TEMP		-20.0 °F To 180.0 °F	Look up table		Unit type equals FLEXSYS and dewpoint reset equals enabled
DEW POINT		30.0 °F To 100.0 °F	Derived		
MAXIMUM BYPASS	1	20.0 To 40.0%	40%	Setpoints / Cooling	Unit type equals FLEXSYS
DEW POINT RESET	1	User Enabled User Disabled	USER DISABLED	Program / Cooling	Unit type equals FLEXSYS
UNDER FLR TEMP OVRD	1	Active - Inactive	DERIVED		Unit type equals FLEXSYS
ACTIVE SLAB CONTROL	1	User Enabled User Disabled	USER DISABLED	Program / Cooling	Unit type equals FLEXSYS
1ST STAGE COOLING SETPOINT	1	55.0 °F To 60.0 °F	60.0 °F	Setpoints / Cooling	Unit type equals CONSTANT VOLUME or SZVAV
2ND STAGE COOLING SETPOINT	1	50.0 °F To 60.0 °F	55.0 °F	Setpoints / Cooling	Unit type equals CONSTANT VOLUME or SZVAV
SAT LOW SETPOINT	1	50.0 °F To 60.0 °F	55.0 °F	Setpoints / Cooling	Unit type equals Variable AIR VOLUME or SZVAV
SAT HIGH SETPOINT	1	55.0 °F To 65.0 °F	65.0 °F	Setpoints / Cooling	Unit type equals Variable AIR VOLUME or SZVAV
<b>OAT SETPOINT FOR</b>					
LOW SAT	1	Oat Setpoint For High Sat To 90 °F	80.0 °F	Setpoints / Cooling	Unit type equals Variable AIR VOLUME and sat reset method equals outside temp
HIGH SAT	1	60.0 °F To Oat Setpoint For Low Sat	70.0 °F	Setpoints / Cooling	Unit type equals Variable AIR VOLUME and sat reset method equals outside temp
<b>RAT SETPOINT FOR</b>					
LOW SAT	1	Rat Setpoint For High Rat +5.0 °F To 90.0 °F	90.0 °F	Setpoints / Cooling	Unit type equals Variable AIR VOLUME and sat reset method equals return temp
HIGH SAT	1	Rat Cooling Setpoint To Rat Setpoint For Low Sat -5.0 °F	80.0 °F	Setpoints / Cooling	Unit type equals Variable AIR VOLUME and sat reset method equals return temp
<b>FAN SPEED SETP FOR</b>					
LOW SAT	1	Fan Speed Setp For High Sat To 100%	90%	Setpoints / Cooling	Unit type equals Variable AIR VOLUME and sat reset method equals supply fan speed
HIGH SAT	1	50% To Fan Speed Setp For Low Sat	70%	Setpoints / Cooling	Unit type equals Variable AIR VOLUME and sat reset method equals supply fan speed
EVAP LEAVING AIR TEMP HIGH	1	50.0 °F To 60.0 °F	60.0 °F	Setpoints / Cooling	Unit type equals FLEXSYS
EVAP LEAVING AIR TEMP LOW	1	50.0 °F To 60.0 °F	50.0 °F	Setpoints / Cooling	Unit type equals FLEXSYS

**TABLE 43 - COOLING (CONT'D)**

DISPLAY TEXT	PASS WORD LEVEL	RANGE	DEFAULT	SETTING LOCATION	SHOW WHEN UNIT TYPE IS
SUP AIR TEMPERING	2	User Enabled User Disabled	USER DISABLE	Program / Cooling	Unit type equals Variable AIR VOLUME or FLEXSYS
MECH CLG LOCKOUT TEMP	1	0.0 °F To 65.0 °F	50.0 °F	Setpoints / Cooling	PRESS TRANS PKG AND LOW AMBIENT PKG OTHER THAN NONE
MECH CLG LOCKOUT TMP MINIMUM	2	-10.0 °F To 0.0 °F	0.0 °F	Setpoints / Cooling	PRESS TRANS PKG AND LOW AMBIENT PKG OTHER THAN NONE
<b>HGRH SUPPLY AIR TEMPERATURE</b>					
HGRH SAT - CURRENT		-51.0 °F To 180.0 °F	LOOK UP TABLE	Cooling	HGRH IS INSTALLED
HGRH ACTIVE SETPOINT		55.0 °F To 75.0 °F	DERIVED		
HGRH RAT SETPOINT FOR HIGH SAT	1	60.0 °F - HGRH RAT Setpoint for Low SAT	70.0 °F	Setpoints / Cooling	HGRH IS INSTALLED
HGRH RAT SETPOINT FOR LOW SAT	1	HGRH RAT Setpoint for High SAT - 95.0 °F	80.0 °F	Setpoints / Cooling	HGRH IS INSTALLED
HGRH SAT HIGH SETPOINT	1	HGRH SAT Low Setpoint - 75.0 °F	65.0 °F	Setpoints / Cooling	HGRH IS INSTALLED
HGRH SAT LOW SETPOINT	1	50.0 °F - HGRH SAT High Setpoint	55.0 °F	Setpoints / Cooling	HGRH IS INSTALLED
RA-RH FOR HIGH SA-DEWPT	1	30% - RA-RH for Low SA-DEWPT	50%	Setpoints / Cooling	HGRH IS INSTALLED
RA-RH FOR HIGH SA-DEWPT	1	RA-RH for High SA-DAWPT - 70%	60%	Setpoints / Cooling	HGRH IS INSTALLED

\* ONLY THE ZONE TEMP SCREEN FOR THE CURRENT ACTIVE MODE WILL BE SHOWN.

**TABLE 44 - COMPRESSOR SYSTEMS (1, 2, OR 3)**

DISPLAY TEXT	PASS WORD LEVEL	RANGE	DEFAULT	SETTING LOCATION	SHOW WHEN UNIT TYPE IS
COMP SYS* STATUS		Normal - Comp A on / Normal - Comp B on / Normal - both on / Normal - both off / Safety trip / Safety fault / Safety lockout / Low amb inhibit / Low suct temp unl / High dp unload / user disabled	Derived		Always
COMP SYS* STATE	1	STOP / RUN / LOCKOUT / AUTO RESET	Derived	Options / Comp Sys	Always

**TABLE 44 - COMPRESSOR SYSTEMS (1, 2, OR 3) (CONT'D)**

DISPLAY TEXT	PASS WORD LEVEL	RANGE	DEFAULT	SETTING LOCATION	SHOW WHEN UNIT TYPE IS
CONDENSER FAN 1A / 1		Off / On	Derived		
CONDENSER FAN 1B / 2		Off / On	Derived		
CONDENSER FAN 2A / 3		Off / On	Derived		
CONDENSER FAN 2B / 4		Off / On	Derived		
<b>SAFETY INPUT</b>					
LPCO		okay - faulted	Derived		Always
CHAIN		okay - faulted	Derived		
SUCTION TEMP		-20.0 °F To 180.0 °F	Look Up Table		Press trans pkg indicates that transducers are not installed for the applicable system
<b>PRESSURE</b>					
DISCHARGE *		0 TO 200 PSIG (R22/R407C) - 0 TO 400 PSIG (R-410a)	Look Up Table		Press trans pkg indicates that transducers are installed for the applicable system
SUCTION *		0 TO 500 PSIG (R22 / R407C) - 0 TO 650 (R-410a)	Look Up Table		
<b>TEMPERATURE</b>					
SUCTION	1	-20.0 °F To 180.0 °F	Look Up Table		Press trans pkg indicates that transducers are installed for the applicable system
SUPERHEAT		0.0 °F To 50.0 °F	Derived		
<b>CURRENT RUN TIME</b>					
COMP A		HH:MM:SS	Derived		Always
COMP B		HH:MM:SS	Derived		
PUMPDOWN	2	USER Enabled USER Disabled	Disabled	Program / Comp Sys.	Always
<b>READY TO RUN</b>					
COMP A		Yes - no	Derived		Always
COMP B		Yes - no	Derived		
<b>READY TO STOP</b>					
COMP A		Yes - no	Derived		Always
COMP B		Yes - no	Derived		
SYSTEM UNLOADING PRESSURE	2	450 - 650 PSIG	620 Psig	Setpoints / Comp Sys	Press trans pkg does not equal NONE
PRESS TRANS PKG	2	None / Sys 1 / Sys 1, 2	None	Optional / Comp Sys	Always
LOW AMBIENT PKG	2	None / Sys 1 / Sys 1, 2	None	Optional / Comp Sys	Always

\* MAY BE 1 OR 2



**TABLE 45 - SUPPLY SYSTEM**

DISPLAY TEXT	PASS WORD LEVEL	RANGE	DEFAULT	SETTING LOCATION	SHOW WHEN UNIT TYPE IS
SUPPLY SYS STATUS		Normal - Active Normal - Inactive Safety Trip Safety Fault Safety Lockout			Always
<b>SUPPLY FAN</b>					
OUTPUT		On - Off	Derived		Always
STATUS		Running Stopped	Derived		
SUPPLY FAN VFD SPEED		0.0 To 100%	Derived		Unit Type Equals VARIABLE AIR VOLUM or FLEXSYS
SINGLE ZONE VAV MIN VFD SPEED		33 To 66%	50%		Unit Type Equals SINGLE ZONE VAV
<b>DUCT STATIC PRESS</b>					
CURRENT		0.00 To 5.00 "W.C.	Look Up Table		Unit Type Equals VARIABLE AIR VOLUM or FLEXSYS
ACTIVE SP		0.00 To 5.00 "W.C.	Derived		
<b>RETURN FAN</b>					
OUTPUT		On - Off	Derived		Power Exhaust Type Equals RETURN w/ EXHAUST + RETURN w/o EXHAUST FANS
STATUS		Running Stopped	Derived		
EXHAUST / RETURN FAN VFD		0.0 To 100%	Derived		Power Exhaust Type Equals RETURN w/ EXHAUST + RETURN w/o EXHAUST FANS
<b>RETURN FAN PRESS</b>					
CURRENT		-1.00 To +1.00 "W.C.	Look Up Table		Power Exhaust Type Equals RETURN w/ EXHAUST + RETURN w/o EXHAUST FANS
ACTIVE SP		0.00 To +1.00 "W.C.	Derived		
DUCT PRESS TRANSDUCER span	2	1.25, 2.5, 5.0	5.0	Setpoints / Supply System	Unit Type Equals VARIABLE AIR VOLUM or FLEXSYS
DUCT STATIC RESET LOW SETP	1	0 - I inwg - SPAN 0 inwg to duct static reset high	1.5 IN-WG	Setpoints / Supply System	Unit Type Equals VARIABLE AIR VOLUM or FLEXSYS
DUCT STATIC RESET HIGH SETP	1	duct static reset low limit to span	2.5 in-wg	Setpoints / Supply System	Unit Type Equals VARIABLE AIR VOLUM or FLEXSYS
DUCT STATIC OVER PRESSURE	2	0 - I in-WG - 5 in-wg	3.0 in-wg	Setpoints / Supply System	Unit Type Equals VARIABLE AIR VOLUM or FLEXSYS
RETURN PRESSURE HIGH SETP	2	0.15 TO 0.45	0.15	Setpoints / Supply System	Power Exhaust Equals RETURN W/ EXHAUST

**TABLE 46 - HEATING**

DISPLAY TEXT	PASS WORD LEVEL	RANGE	DEFAULT	SETTING LOCATION	SHOW WHEN UNIT TYPE IS
HEATING SYS STATUS		Normal - Active / Normal - Inactive / Faulted / User Disabled / Under Floor Control / None	DERIVED		Always
Heating system TYPE	2	None / Electric/ Staged Gas/ Modulating Gas/ Hot Water/ Steam	NONE	Options / Heating	Always
GAS HEAT CAPACITY	2	375 MBH / 750 MBH / 1125 MBH	375 MBH	Options / Heating	Heat Type Equals STAGED GAS or MODULATING GAS
ELEC HEAT CAPACITY	2	40 KW - 200V 40 KW / 80 KW / 80 KW - 200V/ 100 KW - 200V/ 100 KW / 120 KW/ 160 KW / 200 KW / 240 KW	40 KW	Options / Heating	Heat Type Equals ELECTRIC
<b>SUPPLY AIR TEMP</b>					
CURRENT		-20.0 °F To 180.0° F	Look Up Table		Heat Type Does Not EQUAL NONE
ACTIVE SP		50.0 °F To 120.0° F	Derived		
<b>ZONE TEMP*</b>					
CURRENT		-20.0 °F To 180.0 °F	Look Up Table		Always
OCC ZONE HEATING SETPOINT	1	60.0 °F To OCC ZONE COOLING SETPOINT -2.0 °F	68.0 °F	Setpoints / Heating	
<b>ZONE TEMP*</b>					
CURRENT		-20.0 °F To 180.0 °F	Look Up Table		Always
UNOCC ZONE HEATING SETPOINT	1	50.0 °F To UNOCC ZONE COOLING SETPOINT -2.0 °F	60.0 °F	Setpoints / Heating	
<b>RETURN AIR TEMP</b>					
CURRENT		-20.0 °F To 180.0 °F	Look Up Table		Heat Type Does Not Equal NONE and Unit Equals VARIABLE AIR VOLUM OR FLEXSYS
RAT HEATING SETPOINT	1	55.0 °F - RAT COOLING SETPOINT -2.0 °F	68.0 °F	Setpoints / Heating	
HEAT ENTERING TEMP		-20.0 °F To 180.0 °F	Look Up Table		Heat Type Equals STAGED GAS
<b>STAGED HEAT STATUS</b>					
STGS ON		0 To 6	Derived		Heat Type Equals ELECTRIC or STAGED GAS
STGS AVAL		2 To 6	Derived		

\* ONLY THE ZONE TEMP SCREEN FOR THE CURRENT ACTIVE MODE WILL BE SHOWN.

**TABLE 46 - HEATING (CONT'D)**

DISPLAY TEXT	PASS WORD LEVEL	RANGE	DEFAULT	SETTING LOCATION	SHOW WHEN UNIT TYPE IS
<b>HW / STEAM</b>					
VALVE POS		0.0 To 100%	Derived		Heat Type Equals HOT WATER HEAT STEAM
FRZ STAT		OK TRIPPED	Derived		
HEATING CONTROL OFFSET		1 °F To 100.0 °F	Derived		
<b>MOD FURNACE OUTPUT</b>					
RELATIVE		0.0 To 100%	Derived		Heat Type Equals MODULATING GAS
APRX RATE		37.5 To 900.0 MBH	Derived		
FURNACE 1A MODE		OFF / PURGE / IGNITION / ON - LOW / ON - HIGH / SAFETY TRIP / SAFETY FAULT / SAFETY LOCKOUT / FAULT - L/O	Derived		Heat Type Equals MODULATING GAS
<b>FURNACE 1A MODE</b>					
RELATIVE		0 TO 100%	Derived		Heat Type Equals MODULATING GAS
APRX RATE		37.5 TO 150.0 MBH	Derived		
FURNACE 1B MODE		OFF / PURGE / IGNITION / ON / SAFETY TRIP / SAFETY FAULT / SAFETY LOCKOUT / FAULT -L/O	Derived		Heat Type Equals MODULATING GAS
FURNACE 1 MODE		OFF / PURGE / IGNITION / ON-LOW / ON - HIGH / SAFETY TRIP / SAFETY FAULT / SAFETY LOCKOUT / FAULT -L/O	Derived		Heat Type Equals STAGED GAS
FURNACE 2 MODE		OFF / PURGE / IGNITION / ON - LOW / ON - HIGH / SAFETY TRIP / SAFETY FAULT / SAFETY LOCKOUT / FAULT -L/O	Derived		Gas Heat Size Equals 750 MBH or 1125 MBH
FURNACE 3 MODE		OFF / PURGE / IGNITION / ON - LOW / ON -HIGH / SAFETY TRIP / SAFETY FAULT / SAFETY LOCKOUT / FAULT -L/O	Derived		Gas Heat Size Equals 1125 MBH

\* ONLY THE ZONE TEMP SCREEN FOR THE CURRENT ACTIVE MODE WILL BE SHOWN.

**TABLE 46 - HEATING (CONT'D)**

DISPLAY TEXT	PASS WORD LEVEL	RANGE	DEFAULT	SETTING LOCATION	SHOW WHEN UNIT TYPE IS
HEATING SYSTEM	1	User Enabled User Disabled	User Enabled	PROGRAM / Heating	Heat Type Does Not Equal None
MORNING WARM UP	1	User Enabled User Disabled	User Disabled	PROGRAM / Heating	Heat Type Does Not Equal NONE And Constant Volume Control Method Does Not Equal STAGED
ADAPT MORN WARM UP	1	User Enabled User Disabled	User Disabled	PROGRAM / Heating	Heat Type Does Not Equal NONE And Constant Volume Control Method Does Not Equal STAGED
NIGHT SET BACK	1	User Enabled User Disabled	User Disabled	PROGRAM / Heating	Heat Type Does Not Equal NONE
HEAT LIMIT TEMPERATURE	2	100.0 °F To 150.0 °F	130.0 °F	SETPOINTS / Heating	Heat Type Does Not Equal NONE
HEATING SAT	1	80.0 °F To 115.0 °F	100.0 °F	SETPOINTS / Heating	Heat Type Does Not Equal NONE, Unit Type Equals VARIABLE AIR VOLUM, FLEXSYS
HW VALVE ACTION	2	Direct - Reverse	Direct	PROGRAM / Heating	Heating Type Equals HOT WATER STEAM
1ST STAGE Heating SETPOINT	1	80.0° F - 95.0° F	85.0° F	SETPOINTS / Heating	Heat Type Does Not Equal NONE And Unit Type Equals CONSTANT VOLUME or SZVAV
2ND STAGE HEATING SETPOINT	1	95.0 °F To 115.0 °F	100.0 °F	Setpoints / Heating	Heat Type Does Not Equal NONE And Unit Type Equals CONSTANT VOLUME or SZVAV
DAILY WARM UP TIME DAY 1		0 Min. To Morning Warm Up Max Time	Derived		Heat Type Does Not Equal NONE And Morn Warm Up Equals ENABLED
DAILY WARM UP TIME DAY 2		0 Min. To Morning Warm Up Max Time	Derived		Heat Type Does Not Equal NONE And Morn Warm Up Equals ENABLED
DAILY WARM UP TIME DAY 3		0 Min. To Morning Warm Up Max Time	Derived		Heat Type Does Not Equal NONE And Morn Warm Up Equals ENABLED
DAILY WARM UP TIMER		0 Min. To Morning Warm Up Max Time	Derived		Heat Type Does Not Equal NONE And Morn Warm Up Equals ENABLED
MORNING WARM UP OPT TIME		0 Min. To Morning Warm Up Max Time	Derived		Heat Type Does Not Equal NONE And Morn Warm Up Equals ENABLED
MORNING WARM UP MAX TIME	1	15 - 240 Min.	120 Min.	Setpoints/Heating	Heat Type Does Not Equal NONE And Morn Warm Up Equals ENABLED

\* ONLY THE ZONE TEMP SCREEN FOR THE CURRENT ACTIVE MODE WILL BE SHOWN.

**TABLE 47 - ECONOMIZER**

DISPLAY TEXT	PASS WORD LEVEL	RANGE	DEFAULT	SETTING LOCATION	SHOW WHEN UNIT TYPE IS
ECONO SYS STATUS		NORMAL - ACTIVE / NORMAL - INACTIVE / FAULTED / USER DISABLED / NONE	Derived		Always
ECONO INSTALLED	2	NONE / DRYBULB / SINGLE ENTHALPY / DUAL ENTHALPY	None	Options / Economizer	Always
ECONO METHOD TO USE	1	DRY BULB / SINGLE ENTHALPY / DUAL ENTHALPY / BEST AVAILABLE	Best Available	Options / Economizer	Economizer Installed Does Not Equal None
ECONO METHOD ACTIVE		DRY BULB / SINGLE ENTHALPY / DUAL ENTHALPY	Derived		Economizer Installed Does Not Equal None
ECONOMIZER CONTROL OUTPUT		0 To 100%	Derived		Economizer Installed Does Not Equal None
OUTSIDE AIR TEMP		-20.0 °F To 180.0 °F	Look Up Table		Economizer Installed Does Not Equal None
<b>OUTSIDE AIR</b>					
HUMIDITY		0 To 100%	Look Up Table		Economizer Installed Equals SINGLE ENTHALPY or DUAL ENTHALPY
ENTHALPY		7.2 To 204.9 BTU/LB	Look Up Table		Economizer Installed Equals SINGLE ENTHALPY or DUAL ENTHALPY
RETURN AIR TEMP		-20.0 °F To 180.0 °F	Look Up Table		Economizer Installed Equals DUAL ENTHALPY
<b>RETURN AIR</b>					
HUMIDITY		0 To 100%	Look Up Table		Economizer Installed Equals DUAL ENTHALPY
ENTHALPHY		7.2 To 204.9 BTU/LB	Look Up Table		Economizer Installed Equals DUAL ENTHALPY
OUTSIDE AIR ENTHALPY SETPOINT	1	22.0 To 40.0 BTU/LB	28.0 BTU/LB	Setpoints / Economizer	Economizer Installed Does Not Equal None
ECONOMIZER SYSTEM	1	User Enabled User Disabled	Disabled	Program / Economizer	Economizer Installed Does Not Equal None

**6**

**TABLE 48 - VENTILATION**

DISPLAY TEXT	PASS WORD LEVEL	RANGE	DEFAULT	SETTING LOCATION	SHOW WHEN UNIT TYPE IS
VENT SYS STATUS		Normal - Active/ Normal - Inactive / Faulted / User Disabled / None	Derived		ALWAYS
DAMPER HARDWARE	2	None / 2 Position/ Standard/ Minimum Iaq / Full Iaq/ 1/3 - 2/3 Iaq/ tek air full Iaq	Standard Dampers	Options / Ventilation	ALWAYS
VENTILATION CONTROL	1	Fixed Minimum / Demand	Fixed Minimum	Options / Ventilation	Damper Hardware Does Not Equal None Or 2 Position
<b>OA DAMPER POSITION</b>					
CURRENT		0.0 To 100%	Derived		Damper Hardware Does Not Equal None
ACTIVE SP		0.0 To 100%	Derived		
IAQ DMPR AIR FLOWS					
OA FLOW 1		0 To Derived Span	Derived		Damper Hardware TEK AIR FULL IAQ
OA FLOW 2		0 To Derived Span	Derived		
<b>OUTSIDE AIR FLOW</b>					
TOTAL		0 To Derived Span	Derived		Damper Hardware TEK AIR FULL IAQ
ACTIVE SP		0 To Derived Span	Derived		
VENTILATION DEMAND		0-100%	Derived		Ventilation Control Equals Demand
<b>CO2 LEVEL</b>					
OUTSIDE		0 To 2000 PPM	Look Up Table		Ventilation Control Equals Demand
INSIDE		0 To 2000 Ppm	Look Up Table		
<b>CO2 OFFSET</b>					
CURRENT		± 0 To 2000 Ppm	Derived		Ventilation Control Equals Demand
SETPOINT	1	100 To 1000 Ppm	500 Ppm	Setpoints / Ventilation	
OA DAMPER MINIMUM POSITION	1	0 - OA Damper Maximum Position	15%	Setpoints / Ventilation	Damper Hardware Does Not Equal None Or 2 Position Damper
OA DAMPER MAXIMUM POSITION	1	OA Damper Minimum Position To 100%	30%	Setpoints / Ventilation	Damper Hardware Does Not Equal None Or 2 Position Damper
CONTINUOUS VENT	1	User Enabled User Disabled	User Enabled	Program / Ventilation	Unit Type Equals CONSTANT VOLUME or SZVAV
COMFORT VENTILATION	1	User Enabled User Disabled	User Disabled	Program / Ventilation	Unit Type Equals CONSTANT VOLUME or SZVAV

**TABLE 48 - VENTILATION (CONT'D)**

DISPLAY TEXT	PASS WORD LEVEL	RANGE	DEFAULT	SETTING LOCATION	SHOW WHEN UNIT TYPE IS
OUTSIDE AIR MINIMUM FLOW	1	MINIMUM - DERIVED SPAN X 5% MAXIMUM - THE LOWER OF DERIVED SPAN X 50% AND OUTSIDE AIR MAXIMUM FLOW	Derived Span x 15%	Setpoints / Ventilation	Damper Hardware TEK AIR FULL IAQ And Ventilation Control Set To Demand
OUTSIDE AIR MAXIMUM FLOW	1	MINIMUM - OUTSIDE AIR MINIMUM FLOW MAXIMUM - DERIVED FLOW	Derived Span x 30%	Setpoints / Ventilation	Damper Hardware TEK AIR FULL IAQ And Ventilation Control Set To Demand
MINIMUM OA FLOW SETPOINT	1	0 To 100%	Derived Span x 15%	Setpoints / Ventilation	Damper Hardware TEK AIR FULL IAQ Control Set To Fixed Minimum
VENTILATION SYSTEM	1	User Enabled User Disabled	User Enabled	Program / Ventilation	Damper Hardware Does Not Equal None

**TABLE 49 - EXHAUST**

DISPLAY TEXT	PASS WORD LEVEL	RANGE	DEFAULT	SETTING LOCATION	SHOW WHEN UNIT TYPE IS
EXHAUST SYS STATUS		Normal - Active / Normal - Inactive / Faulted / User Disabled / None	Derived		ALWAYS
POWER EXHAUST TYPE	2	NONE / ON-OFF DAMPER CTRL / ON-OFF PRESS CNTRL / MODULATE DAMPER - VFD / RETURN FAN W/ EXH / RETURN FAN W/O EXH	Setting	OPTIONS / EXHAUST	ALWAYS
<b>BUILDING PRESSURE</b>					
CURRENT		-0.50 To 0.50 "W.C.	Look Up Table		Power Exhaust Does Not Equal None or ON-OFF DAMPER CTRL
ACTIVE SETPOINT	1	-0.15 To +0.15 "W.C.	0.00 "W.C.	Setpoints / Exhaust	
<b>EXHAUST FAN</b>					
OUTPUT		ON - OFF	Derived		POWER EXHAUST EQUALS ON OFF DAMPERS CTRL, ON-OFF PRESS CNTRL, MODULATE DAMPER - VFD FAN
STATUS		STOPPED / RUNNING	Derived		
EXHAUST DAMPER POSITION		0.0 TO 100%	DERIVED		POWER EXHAUST EQUALS MODULATE DAMPER - VFD, OR RETURN FAN W/ EXH

**6**

**TABLE 49 - EXHAUST (CONT'D)**

EXHAUST / RETURN FAN VFD		0.0 To 100%	DERIVED		Power Exhaust Equals MODULATE DAMPER - VFD
BLDG PRESSURE CNTRL OFFSET	1	- 0.15 "W.C. To +0.15	0.00 "W.C.	Setpoints / Exhaust	Power Exhaust Equals ON - OFF PRESS CTRL
ECONO OUTPUT FOR FAN START	1	econo output for fan stop to 100%	10 %	Setpoints / Exhaust	Power Exhaust Equals ON - OFF PRESS CTRL
ECONO OUTPUT FOR FAN STOP	1	0 to econo output for fan start	5%	Setpoints / Exhaust	Power Exhaust Equals ON - OFF PRESS CTRL
EXHAUST OUTPUT FOR FAN START	1	exhaust output for fan stop to 100%	10%	Setpoints / Exhaust	Power Exhaust Equals MODULATE DAMPER - VFD
EXHAUST OUTPUT FOR FAN STOP	1	0 - to exhaust output for fan start	5%	Setpoints / Exhaust	Power Exhaust Equals MODULATE DAMPER - VFD

## SETPOINTS

All “Setpoints” values are numeric. Setpoints parameters can be viewed under their respective menu key on the left side of the keypad; however, they can only be changed under the Setpoints key using the following procedure. Press the “Setpoints” key to enter the “Setpoints” menu. The Enter Password screen will appear. All Setpoints parameters require the use of a password before they can be changed. See *Password on page 150* for information on how to enter a Password into the User Interface. If a Level 1 password is entered, only Level 1 setpoints will be available for change. Entering a Level 2 password will make all setpoints available. After the password has been accepted, use the ◀ key or the ▶ key to select the menu subsection: Unit, Cooling, Compressor Systems, Supply System, Heating, Economizer, Ventilation, or Exhaust, that contains the parameter you would like to change. The Setpoints contained under each of these menu subsections and their password level is contained in *Tables 42 through 49 starting on page 124*. Then use the ▼ key and the ▲ key to navigate to the parameter you want to change. Follow the instructions given in the Data Entry Keys section to change the value.

## PROGRAM

All “Program” information is USER ENABLED/ USER DISABLED values. Program parameters can be viewed under their respective menu key on the left side of the keypad; however, they can only be changed under the Program key using the following procedure. Press the “Program” key to enter the “Program” menu. The Enter Password screen will appear. All Program parameters require the use of a password before they can be changed. See *Password on page 150* for information on how to enter a Password into the User Interface. If a Level 1 password is entered, only Level

1 “program” information will be available for change. Entering a Level 2 password will make all “program” information available. After the password has been accepted, use the ◀ key or the ▶ key to select the menu subsection: Unit, Cooling, Compressor Systems, Supply System, Heating, Economizer, Ventilation, Exhaust, which contains the parameter you would like to change. The parameters contained under each of these menu subsections and their password level are contained in *Tables 42 through 49 starting on page 124*. Then use the ▼ key and the ▲ key to navigate to the parameter you want to change. Follow the instructions given in the Data Entry Keys section to change the parameter to the desired value.

## OPTIONS

All “Options” information is selected from the listed parameter data. Options parameters can be viewed under their respective menu key on the left side of the keypad; however, they can only be changed under the Options key using the following procedure. Press the “Options” key to enter the “Options” menu. The Enter Password screen will appear. All Option parameters require the use of a password before they can be changed. See *Password on page 150* for information on how to enter a Password into the User Interface. If a Level 1 password is entered, only Level 1 “options” information will be available for change. Entering a Level 2 password will make all “options” information available. After the password has been accepted, use the ◀ key or the ▶ key to select the menu subsection: Unit, Cooling, Compressor Systems, Supply System, Heating, Economizer, Ventilation, or Exhaust that contains the parameter you would like to change. The parameters contained under each of these menu sub-



sections and their password level is contained in *Tables 42 through 49 starting on page 124*. Then use the ▼ key and the ▲ key to navigate to the parameter you want to change. Follow the instructions given in the Data Entry Keys section to change the parameter to the desired value.

### DATE / TIME

To change the day, time, and date press the DATE/TIME key. The ▼ key is used to scroll to the next item to be programmed and the ▲ key scrolls to the previous item. The following messages will be displayed. The first line will be an active display and the second line will be the entry line.

CLOCK	FRI	18 JUN 2004	10:15:33 AM
DAY OF MONTH		=XX	

CLOCK	FRI	18 JUN 2004	10:15:33 AM
MONTH		=XX	

CLOCK	FRI	18 JUN 2004	10:15:33 AM
YEAR		=XXXX	

CLOCK	FRI	18 JUN 2004	10:15:33 AM
HOUR		=XX	

CLOCK	FRI	18 JUN 2004	10:15:33 AM
MINUTE		=XX	

CLOCK	FRI	18 JUN 2004	10:15:33 AM
DAY OF WEEK		=XXX	

CLOCK	FRI	18 JUN 2004	10:15:33 AM
12 HOUR PERIOD		=XX	

CLOCK	FRI	18 JUN 2004	10:15:33 AM
TIME FORMAT		=XXXXXXX	

CLOCK	FRI	18 JUN 2001	10:15:33 AM
POWER OFF TIME		=XXXXX	

Follow the instructions given in the Data Entry Keys section to change the above values.

### SCHEDULE

The “clock schedule” function can be USER ENABLED / USER DISABLED by using the schedule screen below.

To set the schedule, press the SCHEDULE key. The display will show the following message:

SCHEDULE	✓ TO EDIT
OCCUPANCY SCHEDULE	USER ENABLED

SCHEDULE	MON	✓ TO EDIT
+START	=06:00 AM	STOP =10:00 PM

SCHEDULE	TUE	✓ TO EDIT
START	=06:00 AM	STOP =10:00 PM

SCHEDULE	WED	✓ TO EDIT
START	=06:00 AM	STOP =10:00 PM

SCHEDULE	THU	✓ TO EDIT
START	=06:00 AM	STOP =10:00 PM

SCHEDULE	FRI	✓ TO EDIT
START	=06:00 AM	STOP =10:00 PM

SCHEDULE	SAT	✓ TO EDIT
START	=06:00 AM	STOP =10:00 PM

SCHEDULE	SUN	✓ TO EDIT
START	=06:00 AM	STOP =10:00 PM

To change the start or stop time, press the ✓ key. The line under the 0 is the cursor. If the start time is wrong, it may be changed from the numeric keypad. Once the correct value (hour and minute) is entered, press the ✓ key. The cursor will then move to the AM/PM selection. This value may be chosen by the +/- key and entered by pressing the ✓ key. This process may be followed until the hour, minutes, and meridian of both the START and STOP points are set. Press the ▼ key to get the schedule for the next day to appear. The start and stop time of each day may be programmed differently. If you want to view the schedule without making a change, simply press the ▼ key until the day you wish to view appears. The ▲ key will scroll backwards to the previous screen.

After the SUN (Sunday) schedule appears on the display a subsequent press of the ▼ key will display the Holiday schedule. This is a two-part display. The first reads:

<b>SCHEDULE</b>	<b>HOL</b>
<b>START =06:00 AM</b>	<b>STOP =10:00 PM</b>

The times may be set using the same procedure as described above for the days of the week.

Continue pressing the ▼ key to set the 15 holiday dates. The display will read:

<b>SCHEDULE</b>	<b>MMDD</b>
<b>HOLIDAY 01</b>	<b>= 1225</b>

The month and the day of each holiday are entered in this format. Enter 0000 to not specify a holiday. The MMDD is displayed when the value is being edited to remind the operator what the format of this number is. E.g. 1225 represents December 25.

The line below the empty space is the cursor and will move to the next or previous empty space when the ◀ key or the ▶ key is pressed. To set the Holiday, the cursor is moved to the space following the day of the week of the holiday and the +/- key is pressed. An \* will appear in the space signifying that day as a holiday. The Holiday schedule must be programmed weekly. If there is no holiday, the +/- key is used to delete the \*. The ✓ key is used to accept the holiday schedule for the next seven days.

**OPERATING HOURS / START COUNTER**

Compressor Operating hours and Compressor Starts; Supply Fan Operating hours and Supply Fan starts; Exhaust Fan operating hours and Exhaust Fan starts; and Return Fan operating hours and Return Fan starts are displayed via one key press. The maximum value for both hours and starts is 99,999, at which point they will roll over to 0. Following are the displays.

**TABLE 50 - OPERATING HOURS / START COUNTER**

DISPLAY TEXT	PASS WORD LEVEL	RANGE	DEFAULT	SETTING LOCATION	SHOW WHEN
COMPRESSOR 1A OPER HRS COMPRESSOR 1A STARTS	1		DERIVED		
COMPRESSOR 1B OPER HRS COMPRESSOR 1B STARTS	1		DERIVED		
COMPRESSOR 2A OPER HRS COMPRESSOR 2A STARTS	1		DERIVED		
COMPRESSOR 2B OPER HRS COMPRESSOR 2B STARTS	1		DERIVED		
CONDENSER FAN 1A					
CONDENSER FAN 1B					
CONDENSER FAN 2A					
CONDENSER FAN 2B					
EXHAUST FAN OPER HRS EXHAUST FAN STARTS	1		DERIVED		POWER EXHAUST ON/OFF DMPR / ON/OFF PRESS / MODULATE DAMPER - VFD.
SUPPLY FAN OPER HRS SUPPLY FAN STARTS	1		DERIVED		
RETURN FAN OPER HRS RETURN FAN STARTS	1		DERIVED		Supply System Type Equals Return Fan W/EXH RETURN W/O EXHAUST.

Shown below is a typical screen example.

HOURS / STARTS	oper HRS.	xxxxx
COMPRESSOR 1A	Starts	xxxxx

### PRINT

The PRINT function is not available. In order to view operating data, refer to SECTION 8 – SERVICE for information on how to use a MULTI-MEDIA CARD to record operating data.

### SERVICE

To enter Service Mode, press the SERVICE key. The following message is the initial screen and is displayed when the SERVICE key is pressed, unless a Level 2 password is active.

<b>SERVICE ENTER PASSWORD</b>
-----------------------------------

All the DIGITAL outputs (DO) except for the compressors can be forced ON. In order to force the outputs the LOCAL STOP switch must be in the OFF position. To force an output ON use the ◀ or ▶ key to navigate to the SERVICE DO section. Then use the ▲ or ▼ key to select the output you want to force ON. Press the ✓ key and then use the ▶ key to switch it from OFF to ON. Press the ✓ key again to energize the output. Repeat the above process in reverse to turn the forced output back to OFF.

All the ANALOG outputs (AO) can be forced ON. In order to force the outputs the LOCAL STOP switch must be in the OFF position. To force an output ON use the ◀ or ▶ key to navigate to the SERVICE AO section. Then use the ▲ or ▼ key to select the output you want to force ON. Press the ✓ key and then use the numeric key pad to enter the output value. Press the ✓ key again to energize the output. Repeat the above process in reverse to turn the forced output back to 0.0. Failure to do so will leave the forced output value in place until a different value is initiated by the operation of the unit.

The ▶ key can be used to jump to the beginning of the next section of displays and the ◀ key can be used to jump to the beginning of the previous section of displays. The sections of displays are as follows:

- Parameters
- Analog Inputs
- Digital Inputs
- Digital Outputs
- Analog Outputs

The attached Table 51 on page 139 lists the Displayed Text, Input or Output type, Unit Control terminal location (ID), Value Range, and when item is displayed.

**TABLE 51 - SERVICE**

DISPLAY TEXT	TYPE	ID	VALUE RANGE	LOCATION	DESCRIPTION
DATA LOG FORMAT			OFF		USED TO ACTIVATE THE DATA LOG FEATURE OF THE CONTROL
DATA LOG ERROR	ERROR DETAIL		SEE Table 66 on page 195		DATA LOG ERROR DETAIL (ONLY DISPLAYED WHEN ERROR IS PRESENT)
	ERROR STATE		SEE Table 65 on page 193		DATA LOG ERROR STATE (ONLY DISPLAYED WHEN ERROR IS PRESENT)
UPDATE FLASH			ON / OFF		USED TO UPDATE CONTROL SOFTWARE
UPDATE FLASH ERROR					DESCRIPTION OF THE ERROR (ONLY DISPLAYED WHEN ERROR IS PRESENT)
FACTORY RUN TESTER			USER DISABLE / USER ENABLE		ONLY USED FOR FACTORY RUN TEST
COMPRESSOR 1A	DIGITAL OUTPUT	TB5-2	ON / OFF	I/O BOARD	STATUS OF THE DIGITAL OUTPUT TO COMPRESSOR 1A

**TABLE 51 - SERVICE (CONT'D)**

DISPLAY TEXT	TYPE	ID	VALUE RANGE	LOCATION	DESCRIPTION
COMPRESSOR 1B	DIGITAL OUTPUT	TB5-4	ON / OFF	I/O BOARD	STATUS OF THE DIGITAL OUTPUT TO COMPRESSOR 1B
COMPRESSOR 2A	DIGITAL OUTPUT	TB5-6	ON / OFF	I/O BOARD	STATUS OF THE DIGITAL OUTPUT TO COMPRESSOR 2A
COMPRESSOR 2B	DIGITAL OUTPUT	TB5-8	ON / OFF	I/O BOARD	STATUS OF THE DIGITAL OUTPUT TO COMPRESSOR 2B
CONDENSER FAN 1A/1	DIGITAL OUTPUT	TB3-7	ON / OFF	I/O BOARD	STATUS OF DIGITAL OUTPUT TO CONDENSER FAN 1A
CONDENSER FAN 1B/2	DIGITAL OUTPUT	TB3-8	ON / OFF	I/O BOARD	STATUS OF DIGITAL OUTPUT TO CONDENSER FAN 1B
CONDENSER FAN 2A/3	DIGITAL OUTPUT	TB3-9	ON / OFF	I/O BOARD	STATUS OF DIGITAL OUTPUT TO CONDENSER FAN 2A
CONDENSER FAN 2B/4	DIGITAL OUTPUT	TB3-10	ON / OFF	I/O BOARD	STATUS OF DIGITAL OUTPUT TO CONDENSER FAN 2B
ELECTRIC HEAT STG 1	DIGITAL OUTPUT	TB4-2	ON / OFF	I/O BOARD	STATUS OF ELECTRIC HEAT DIGITAL OUTPUT TO STAGE 1
ELECTRIC HEAT STG 2	DIGITAL OUTPUT	TB4-3	ON / OFF	I/O BOARD	STATUS OF ELECTRIC HEAT DIGITAL OUTPUT TO STAGE 2
ELECTRIC HEAT STG 3	DIGITAL OUTPUT	TB4-4	ON / OFF	I/O BOARD	STATUS OF ELECTRIC HEAT DIGITAL OUTPUT TO STAGE 3
ELECTRIC HEAT STG 4	DIGITAL OUTPUT	TB4-5	ON / OFF	I/O BOARD	STATUS OF ELECTRIC HEAT DIGITAL OUTPUT TO STAGE 4
ELECTRIC HEAT STG 5	DIGITAL OUTPUT	TB4-7	ON / OFF	I/O BOARD	STATUS OF ELECTRIC HEAT DIGITAL OUTPUT TO STAGE 5
ELECTRIC HEAT STG 6	DIGITAL OUTPUT	TB4-8	ON / OFF	I/O BOARD	STATUS OF ELECTRIC HEAT DIGITAL OUTPUT TO STAGE 6
ELECTRIC HEAT STG 7	DIGITAL OUTPUT	TB4-9	ON / OFF	I/O BOARD	STATUS OF ELECTRIC HEAT DIGITAL OUTPUT TO STAGE 7
STG GAS FURN 1 LOW	DIGITAL OUTPUT	TB4-2	ON / OFF	I/O BOARD	STATUS OF STAGED GAS HEAT DIGITAL OUTPUT TO STAGE 1 LOW
STG GAS FURN 1 HIGH	DIGITAL OUTPUT	TB4-3	ON / OFF	I/O BOARD	STATUS OF STAGED GAS HEAT DIGITAL OUTPUT TO STAGE 1 HIGH
STG GAS FURN 2 LOW	DIGITAL OUTPUT	TB4-4	ON / OFF	I/O BOARD	STATUS OF STAGED GAS HEAT DIGITAL OUTPUT TO STAGE 2 LOW
STG GAS FURN 2 HIGH	DIGITAL OUTPUT	TB4-5	ON / OFF	I/O BOARD	STATUS OF STAGED GAS HEAT DIGITAL OUTPUT TO STAGE 2 HIGH
STG GAS FURN 3 LOW	DIGITAL OUTPUT	TB4-7	ON / OFF	I/O BOARD	STATUS OF STAGED GAS HEAT DIGITAL OUTPUT TO STAGE 3 LOW
STG GAS FURN 3 HIGH	DIGITAL OUTPUT	TB4-8	ON / OFF	I/O BOARD	STATUS OF STAGED GAS HEAT DIGITAL OUTPUT TO STAGE 3 HIGH
MOD GAS FURN 1A LOW	DIGITAL OUTPUT	TB4-2	ON / OFF	I/O BOARD	STATUS OF MOD GAS HEAT DIGITAL OUTPUT TO STAGE 1A LOW
MOD GAS FURN 1A HI	DIGITAL OUTPUT	TB4-3	ON / OFF	I/O BOARD	STATUS OF MOD GAS HEAT DIGITAL OUTPUT TO STAGE 1A HIGH

**TABLE 51 - SERVICE (CONT'D)**

DISPLAY TEXT	TYPE	ID	VALUE RANGE	LOCATION	DESCRIPTION
MOD GAS FURN 2 LOW	DIGITAL OUTPUT	TB4-4	ON / OFF	I/O BOARD	STATUS OF MOD GAS HEAT DIGITAL OUTPUT TO STAGE 2 LOW
MOD GAS FURN 2 HIGH	DIGITAL OUTPUT	TB4-5	ON / OFF	I/O BOARD	STATUS OF MOD GAS HEAT DIGITAL OUTPUT TO STAGE 2 HIGH
MOD GAS FURN 3 LOW	DIGITAL OUTPUT	TB4-7	ON / OFF	I/O BOARD	STATUS OF MOD GAS HEAT DIGITAL OUTPUT TO STAGE 3 LOW
MOD GAS FURN 3 HIGH	DIGITAL OUTPUT	TB4-8	ON / OFF	I/O BOARD	STATUS OF MOD GAS HEAT DIGITAL OUTPUT TO STAGE 3 HIGH
MOD GAS FURN 1B	DIGITAL OUTPUT	TB4-9	ON / OFF	I/O BOARD	STATUS OF MOD GAS HEAT DIGITAL OUTPUT TO STAGE 1B
SUPPLY FAN OUTPUT (CV)	DIGITAL OUTPUT	TB6-2	ON / OFF	ALWAYS	STATUS OF SUPPLY FAN DIGITAL OUTPUT ON CONSTANT VOLUME UNITS
EXHAUST FAN OUTPUT (CV)	DIGITAL OUTPUT	TB6-3	ON / OFF	I/O BOARD	STATUS OF EXHAUST FAN DIGITAL OUTPUT ON CV UNITS
VAV HEAT RELAY	DIGITAL OUTPUT	TB1-12	ON / OFF	I/O BOARD	STATUS OF THE DIGITAL OUTPUT FOR THE VAV HEAT RELAY
FAN FAULT	DIGITAL OUTPUT	TB1-6	OKAY / FAULTED	I/O BOARD	DIGITAL OUTPUT THAT IS GENERATED WHEN THERE IS A SUPPLY FAN FAULT
COOL/HEATING FAULT	DIGITAL OUTPUT	TB1-8	ON / OFF	I/O BOARD	DIGITAL OUTPUT THAT IS GENERATED WHEN THERE IS A COOLING/HEATING FAULT
SENSOR/MISC FAULT	DIGITAL OUTPUT	TB1-10	ON / OFF	I/O BOARD	DIGITAL OUTPUT THAT IS GENERATED WHEN THERE IS A SENSOR/MISC FAULT
VAV SUPPLY FAN START	DIGITAL OUTPUT	TB1-2	ON / OFF	I/O BOARD	RUN SIGNAL TO VFD FOR SUPPLY FAN START
VAV EXHAUST FAN START	DIGITAL OUTPUT	TB1-4	ON / OFF	I/O BOARD	RUN SIGNAL TO VFD FOR EXHAUST/RETURN FAN START
SUPPLY FAN VFD SPEED	ANALOG OUTPUT	TB9-1	0-10 VDC	I/O BOARD	ANALOG OUTPUT TO THE SUPPLY FAN VFD
EXHAUST DAMPER POSITION	ANALOG OUTPUT	TB9-7	0-10 VDC	I/O BOARD	ANALOG OUTPUT TO THE EXHAUST DAMPER
EXHAUST / RETURN FAN VFD	ANALOG OUTPUT	TB9-3	0-10 VDC	I/O BOARD	ANALOG OUTPUT TO THE EXHAUST OR RETURN FAN VFD
OA DAMPER POSITION	ANALOG OUTPUT	TB9-5	0-10 VDC	I/O BOARD	ANALOG OUTPUT TO THE ECONOMIZER DAMPERS
HEATING VALVE	ANALOG OUTPUT	TB9-9	0-10 VDC	I/O BOARD	ANALOG OUTPUT TO THE HEATING VALVE
BYPASS DAMPER POSITION	ANALOG OUTPUT	TB9-11	0-10 VDC	I/O BOARD	ANALOG OUTPUT TO THE FLEXSYS BYPASS DAMPER
SUPPLY AIR TEMP CURRENT	ANALOG INPUT	J1-1	0-5 VOLTS	I/O BOARD	ANALOG INPUT FROM THE SUPPLY OR MIXED AIR SENSOR
MX SUPPLY AIR TEMP CURRENT	ANALOG INPUT	J1-1	0-5 VOLTS	I/O BOARD	ANALOG INPUT FROM THE SUPPLY OR MIXED AIR SENSOR

**6**

**TABLE 51 - SERVICE (CONT'D)**

DISPLAY TEXT	TYPE	ID	VALUE RANGE	LOCATION	DESCRIPTION
HEAT EXCHANGER TEMP	ANALOG INPUT	J1-2	0-5 VOLTS	I/O BOARD	ANALOG INPUT FROM THE TEMPERATURE SENSOR POSITIONED BEFORE THE HEAT SECTION
FLEX EVAP TEMP CURRENT	ANALOG INPUT	J1-3	0-5 VOLTS	I/O BOARD	ANALOG INPUT FROM THE TEMPERATURE SENSORS POSITIONED ON THE LEAVING SIDE OF THE EVAPORATOR COIL
OUTSIDE AIR TEMP	ANALOG INPUT	J2-1	0-5 VOLTS	I/O BOARD	ANALOG INPUT FROM THE OUTDOOR AIR TEMPERATURE SENSOR
RETURN AIR TEMP CURRENT	ANALOG INPUT	J2-2	0-5 VOLTS	I/O BOARD	ANALOG INPUT FROM THE RETURN AIR TEMPERATURE SENSOR
OUTSIDE AIR HUMIDITY	ANALOG INPUT	J2-3	0-5 VOLTS	I/O BOARD	ANALOG INPUT FROM THE OUTDOOR AIR HUMIDITY SENSOR
RETURN AIR HUMIDITY	ANALOG INPUT	J2-4	0-5 VOLTS	I/O BOARD	ANALOG INPUT FROM THE RETURN AIR HUMIDITY SENSOR
TEMPERATURE SUCTION 1	ANALOG INPUT	J3-1	0-5 VOLTS	I/O BOARD	ANALOG INPUT FROM THE SYSTEM 1 SUCTION LINE TEMPERATURE SENSOR
TEMPERATURE SUCTION 2	ANALOG INPUT	J3-2	0-5 VOLTS	I/O BOARD	ANALOG INPUT FROM THE SYSTEM 2 SUCTION LINE TEMPERATURE SENSOR
TEMPERATURE SUCTION 3	ANALOG INPUT	J3-3	0-5 VOLTS	I/O BOARD	ANALOG INPUT FROM THE SYSTEM 3 SUCTION LINE TEMPERATURE SENSOR
PRESSURE SUCTION 1	ANALOG INPUT	J3-4	0-5 VOLTS	I/O BOARD	ANALOG INPUT FROM THE SYSTEM 1 SUCTION PRESSURE TRANSDUCER
PRESSURE SUCTION 2	ANALOG INPUT	J4-1	0-5 VOLTS	I/O BOARD	ANALOG INPUT FROM THE SYSTEM 2 SUCTION PRESSURE TRANSDUCER
PRESSURE SUCTION 3	ANALOG INPUT	J4-2	0-5 VOLTS	I/O BOARD	ANALOG INPUT FROM THE SYSTEM 3 SUCTION PRESSURE TRANSDUCER
PRESSURE DISCHARGE 1	ANALOG INPUT	J4-3	0-5 VOLTS	I/O BOARD	ANALOG INPUT FROM THE SYSTEM 1 DISCHARGE PRESSURE TRANSDUCER
PRESSURE DISCHARGE 2	ANALOG INPUT	J4-4	0-5 VOLTS	I/O BOARD	ANALOG INPUT FROM THE SYSTEM 2 DISCHARGE PRESSURE TRANSDUCER
PRESSURE DISCHARGE 3	ANALOG INPUT	J4-5	0-5 VOLTS	I/O BOARD	ANALOG INPUT FROM THE SYSTEM 3 DISCHARGE PRESSURE TRANSDUCER
CO2 LEVEL OUTSIDE	ANALOG INPUT	J5-2	0-5 VOLTS	I/O BOARD	ANALOG INPUT OF THE OUTDOOR CO2 SENSOR
CO2 LEVEL INSIDE	ANALOG INPUT	J5-3	0-5 VOLTS	I/O BOARD	ANALOG INPUT FROM THE INDOOR CO2 SENSOR

**TABLE 51 - SERVICE (CONT'D)**

DISPLAY TEXT	TYPE	ID	VALUE RANGE	LOCATION	DESCRIPTION
RETURN FAN PRESS CURRENT	ANALOG INPUT	J6-1	0-5 VOLTS	I/O BOARD	ANALOG INPUT FROM THE RETURN FAN PRESSURE TRANSDUCER
DUCT STATIC PRESS CURRENT	ANALOG INPUT	J6-2	0-5 VOLTS	I/O BOARD	ANALOG INPUT FROM THE SUPPLY AIR PRESSURE TRANSDUCER
BUILDING PRESSURE CURRENT	ANALOG INPUT	J6-3	0-5 VOLTS	I/O BOARD	ANALOG INPUT FROM THE BUILDING PRESSURE TRANSDUCER
OA FLOW INPUT 1	ANALOG INPUT	J6-4	0 TO 4095 A/D COUNTS (1-5 VOLTS)	I/O BOARD	THIS IS THE AIR FLOW INPUT FROM THE TEK AIR MEASURING STATION
OA FLOW INPUT 2	ANALOG INPUT	J6-5	0 TO 4095 A/D COUNTS (1-5 VOLTS)	I/O BOARD	THIS IS THE AIR FLOW INPUT FROM THE TEK AIR MEASURING STATION
ZONE TEMP CURRENT	ANALOG INPUT	J7-1	0-5 VOLTS	I/O BOARD	ANALOG INPUT FROM THE ZONE TEMPERATURE SENSOR
UNDERFLOOR SLAB TEMP	ANALOG INPUT	J7-2	0-5 VOLTS	I/O BOARD	ANALOG INPUT FROM THE UNDER FLOOR TEMPERATURE SENSOR
UNDERFLOOR AIR HUMIDITY	ANALOG INPUT	J7-3	0-5 VOLTS	I/O BOARD	ANALOG INPUT FROM THE UNDERFLOOR HUMIDITY SENSOR
SUPPLY AIR TEMP RST	ANALOG INPUT	J7-4	0-5 VOLTS	I/O BOARD	HARDWIRED ANALOG INPUT TO RESET THE SUPPLY AIR TEMPERATURE SETPOINT
DUCT STATIC PRES RESET	ANALOG INPUT	J7-5	0-5 VOLTS	I/O BOARD	HARDWIRED ANALOG INPUT TO RESET THE DUCT STATIC PRESSURE SETPOINT
FURNACE STATUS	ANALOG INPUT	J5-1	0-5 VOLTS	I/O BOARD	ANALOG INPUT OF THE FURNACE MULTIPLEXER
FURNACE STATUS COUNTS	ANALOG INPUT	J5-1	0 - 4095	I/O BOARD	STATUS OF THE INPUT FROM THE FURNACE MULTIPLEXER BOARD IN COUNT
FURNACE 1A STAT HI	DIGITAL INPUT	TB01-3	ON / OFF	FURNACE MULTIPLEXER	FURNACE 1A HZ STATUS INPUT TO FURNACE MULTIPLEXER BOARD
FURNACE 1 STATUS	DIGITAL INPUT	TB01-2	ON / OFF	FURNACE MULTIPLEXER	FURNACE 1 STATUS INPUT TO FURNACE MULTIPLEXER BOARD
FURNACE 1A STATUS	DIGITAL INPUT	TB01-2	ON / OFF	FURNACE MULTIPLEXER	FURNACE 1A STATUS INPUT TO FURNACE MULTIPLEXER BOARD
FURNACE 1B STATUS	DIGITAL INPUT	TB01-6	ON / OFF	FURNACE MULTIPLEXER	FURNACE 1B STATUS INPUT TO FURNACE MULTIPLEXER BOARD
FURNACE 2 STATUS	DIGITAL INPUT	TB01-3	ON / OFF	FURNACE MULTIPLEXER	FURNACE 2 STATUS INPUT TO FURNACE MULTIPLEXER BOARD
FURNACE 3 STATUS	DIGITAL INPUT	TB01-4	ON / OFF	FURNACE MULTIPLEXER	FURNACE 3 STATUS INPUT TO FURNACE MULTIPLEXER BOARD
OCCUPANCY STATE	DIGITAL INPUT	TB8-2	OCCUPIED / UNOCCUPIED	I/O BOARD	HARDWIRED DIGITAL INPUT TO PUT THE UNIT INTO THE OCCUPIED MODE
LOCAL STOP	DIGITAL INPUT	TB8-1	RUN / STOP	I/O BOARD	DIGITAL INPUT THAT TURNS THE UNIT ON AND OFF

**6**

**TABLE 51 - SERVICE (CONT'D)**

DISPLAY TEXT	TYPE	ID	VALUE RANGE	LOCATION	DESCRIPTION
FAN (G)	DIGITAL INPUT	TB8-8	ON / OFF	I/O BOARD	HARDWIRED DIGITAL INPUT TO TURN THE SUPPLY FAN ON AND OFF
Y1 LOW COOL	DIGITAL INPUT	TB8-10	ON / OFF	I/O BOARD	HARDWIRED DIGITAL INPUT TO PLACE THE UNIT IN FIRST STAGE COOLING MODE
Y2 HIGH COOL	DIGITAL INPUT	TB8-11	ON / OFF	I/O BOARD	HARDWIRED DIGITAL INPUT TO PLACE THE UNIT IN SECOND STAGE COOLING MODE
W1 LOW HEAT	DIGITAL INPUT	TB8-13	ON / OFF	I/O BOARD	HARDWIRED DIGITAL INPUT TO PLACE THE UNIT IN FIRST STAGE HEATING MODE
W2 HIGH HEAT	DIGITAL INPUT	TB8-14	ON / OFF	I/O BOARD	HARDWIRED DIGITAL INPUT TO PLACE THE UNIT IN SECOND STAGE HEATING MODE
SAFETY INPUT CHAIN 1	DIGITAL INPUT	TB7-1	OKAY / FAULTED	I/O BOARD	DIGITAL INPUT FROM THE COMPRESSOR SYSTEM 1 SAFETY CIRCUIT
SAFETY INPUT CHAIN 2	DIGITAL INPUT	TB7-2	OKAY / FAULTED	I/O BOARD	DIGITAL INPUT FROM THE COMPRESSOR SYSTEM 2 SAFETY CIRCUIT
SAFETY INPUT CHAIN 3	DIGITAL INPUT	TB7-4	OKAY / FAULTED	I/O BOARD	DIGITAL INPUT FROM THE COMPRESSOR SYSTEM 3 SAFETY CIRCUIT
SAFETY INPUTS LPCO 1	DIGITAL INPUT	TB7-5	OKAY / FAULTED	I/O BOARD	DIGITAL INPUT FROM THE COMPRESSOR SYSTEM 1 LOW PRESSURE SAFETY CIRCUIT
SAFETY INPUTS LPCO 2	DIGITAL INPUT	TB7-7	OKAY / FAULTED	I/O BOARD	DIGITAL INPUT FROM THE COMPRESSOR SYSTEM 2 LOW PRESSURE SAFETY CIRCUIT
SUPPLY FAN OUTPUT	DIGITAL INPUT	TB7-11	RUNNING / STOPPED	I/O BOARD	DIGITAL INPUT FOR THE SUPPLY FAN RUN VERIFICATION CIRCUIT
EXHAUST FAN STATUS	DIGITAL INPUT	TB7-11	RUNNING / STOPPED	I/O BOARD	DIGITAL INPUT FROM THE EXHAUST FAN RUN VERIFICATION CIRCUIT
RETURN FAN STATUS	DIGITAL INPUT	TB7-11	RUNNING / STOPPED	I/O BOARD	DIGITAL INPUT FROM THE RETURN FAN RUN VERIFICATION CIRCUIT
FILTER STATUS	DIGITAL INPUT	TB7-13	OKAY / CHANGE	I/O BOARD	DIGITAL INPUT FROM THE DIRTY FILTER PRESSURE SWITCH
HW/STEAM FRZ STAT	DIGITAL INPUT	TB7-14	OKAY / FAULTED	I/O BOARD	DIGITAL INPUT FROM THE HOT WATER FREEZESTAT
SMOKE PURGE 1	DIGITAL INPUT	TB8-4	ON / OFF	I/O BOARD	HARDWIRED DIGITAL INPUT TO PLACE THE UNIT IS SMOKE PURGE 1 MODE
SMOKE PURGE 2	DIGITAL INPUT	TB8-5	ON / OFF	I/O BOARD	HARDWIRED DIGITAL INPUT TO PLACE THE UNIT IS SMOKE PURGE 2 MODE



**TABLE 51 - SERVICE (CONT'D)**

DISPLAY TEXT	TYPE	ID	VALUE RANGE	LOCATION	DESCRIPTION
SMOKE PURGE 3	DIGITAL INPUT	TB8-7	ON / OFF	I/O BOARD	HARDWIRED DIGITAL INPUT TO PLACE THE UNIT IS SMOKE PURGE 3 MODE
DUCT PRES RESET BAS	COMMUN	PORT P1	USER DISABLE / USER ENABLE	IPU BOARD	THIS ITEM MUST BE ENABLED IN ORDER TO COMMUNICATE A DUCT STATIC PRESSURE RESET VALUE TO THE UNIT
DUCT STATIC PRES RESET BAS	COMMUN	PORT P1	0 TO 100%	IPU BOARD	THE DUCT STATIC RESET VALUE BEING COMMUNICATED TO THE UNIT THROUGH THE BAS SYSTEM
EXHAUST CONTROL BAS	COMMUN	PORT P1	ENABLE/ DISABLE	IPU BOARD	ENABLES OR DISABLES CONTROL OF THE EXHAUST FAN OR MODULATING EXHAUST DAMPER (RETURN FAN)
EXHAUST DAMPER/ VFD	COMMUN	PORT P1	0 TO 100%	IPU BOARD	COMMUNICATED SIGNAL TO SET THE POSITION OF THE MODULATING DAMPER (RETURN FAN) OR SPEED OF THE EXHAUST FAN.
FAN (G) BAS	COMMUN	PORT P1	ON / OFF	IPU BOARD	GIVES THE STATUS OF THE COMMUNICATED FAN G INPUT
MORNING WARM UP CMD	COMMUN	PORT P1	ON / OFF	IPU BOARD	GIVES THE STATUS OF THE COMMUNICATED MORNING WARM UP COMMAND
OCCUPANCY COMMAND	COMMUN	PORT P1	OCCUPIED / UNOCCUPIED	IPU BOARD	GIVES THE STATUS OF THE COMMUNICATED OCCUPANCY COMMAND
SMOKE PURGE 1 BAS	COMMUN	PORT P1	ON OFF	IPU BOARD	GIVES THE STATUS OF THE COMMUNICATED SMOKE PURGE 1 COMMAND
SMOKE PURGE 2 BAS	COMMUN	PORT P1	ON OFF	IPU BOARD	GIVES THE STATUS OF THE COMMUNICATED SMOKE PURGE 2 COMMAND
SMOKE PURGE 3 BAS	COMMUN	PORT P1	ON OFF	IPU BOARD	GIVES THE STATUS OF THE COMMUNICATED SMOKE PURGE 3 COMMAND
SAT RESET BAS	COMMUN	PORT P1	USER DISABLE / USER ENABLE	IPU BOARD	THIS ITEM MUST BE ENABLED IN ORDER TO COMMUNICATE A SUPPLY AIR TEMPERATURE RESET VALUE TO THE UNIT
SUPPLY AIR TEMP RESET BAS	COMMUN	PORT P1	0 TO 5 VOLTS	IPU BOARD	THE SUPPLY AIR TEMPERATURE RESET VALUE BEING COMMUNICATED TO THE UNIT THROUGH THE BAS SYSTEM

**6**

**TABLE 51 - SERVICE (CONT'D)**

DISPLAY TEXT	TYPE	ID	VALUE RANGE	LOCATION	DESCRIPTION
SYSTEM STOP	COMMUN	PORT P1	0 - ALLOWS ALL COMPRESSORS TO OPERATE; 1 - TURNS OFF COMPRESSOR SYSTEM 1; 2 - TURNS OFF COMPRESSOR SYSTEM 2; 3 - TURNS OFF COMPRESSOR SYSTEM 3	IPU BOARD	GIVES THE STATUS OF THE COMMUNICATED SYSTEM STOP COMMAND
UNDER FLR HUMI BAS	COMMUN	PORT P1	USER DISABLE / USER ENABLE	IPU BOARD	THIS ITEM MUST BE ENABLED IN ORDER TO COMMUNICATE A UNDER FLOOR HUMIDITY VALUE TO THE UNIT
UNDRFLOOR AIR HUMIDITY BAS	COMMUN	PORT P1	0 TO 100%	IPU BOARD	THE UNDER FLOOR HUMIDITY VALUE BEING COMMUNICATED TO THE UNIT
UNDR FLR TEMP BAS	COMMUN	PORT P1	USER DISABLE / USER ENABLE	IPU BOARD	THIS ITEM MUST BE ENABLED IN ORDER TO COMMUNICATE AN UNDER FLOOR TEMPERATURE VALUE TO THE UNIT
UNDERFLOOR SLAB TEMP BAS	COMMUN	PORT P1	-20 °F TO 180 °F	IPU BOARD	THIS IS THE ACTUAL UNDER FLOOR TEMPERATURE VALUE BEING COMMUNICATED BY THE BAS SYSTEM
UNIT STOP	COMMUN	PORT P1	ON / OFF	IPU BOARD	GIVES THE STATUS OF THE COMMUNICATED UNIT STOP COMMAND
W1 LOW HEAT BAS	COMMUN	PORT P1	ON / OFF	IPU BOARD	GIVES THE STATUS OF THE COMMUNICATED W1 LOW HEAT COMMAND
W2 HIGH HEAT BAS	COMMUN	PORT P1	ON / OFF	IPU BOARD	GIVES THE STATUS OF THE COMMUNICATED W2 HIGH HEAT COMMAND
Y1 LOW COOL BAS	COMMUN	PORT P1	ON / OFF	IPU BOARD	GIVES THE STATUS OF THE COMMUNICATED Y1 LOW COOL COMMAND
Y2 HIGH COOL BAS	COMMUN	PORT P1	ON / OFF	IPU BOARD	GIVES THE STATUS OF THE COMMUNICATED Y2 HIGH COOL COMMAND
ZONE TEMP BAS	COMMUN	PORT P1	-20 °F TO 180 °F	IPU BOARD	GIVES THE ACTUAL VALUE OF THE COMMUNICATED ZONE TEMPERATURE
FIRMWARE CRC	DERIVED		0 TO 99999	ALWAYS	THIS IS THE SIZE OF THE CODE IN THE SOFTWARE AND IS NOT FOR FIELD USE

**TABLE 51 - SERVICE (CONT'D)**

DISPLAY TEXT	TYPE	ID	VALUE RANGE	LOCATION	DESCRIPTION
REAL TIME UI - PEAK 5 SEC AND AVERAGE	DERIVED				THE AVERAGE AND PEAK OVER THE LAST 5 SECONDS TIME USED BY THE USER INTERFACE. THIS IS NOT FOR FIELD USE
REAL TIME UI - LOST AND PEAK	DERIVED				THE LOST AND PEAK TIME USED BY THE USER INTERFACE. THIS IS NOT FOR FIELD USE
REAL TIME CONTROL - PEAK 5 SEC AND AVERAGE	DERIVED				THE AVERAGE AND PEAK OVER THE LAST 5 SECONDS TIME USED BY THE CONTROL. THIS IS NOT FOR FIELD USE
REAL TIME CONTROL - LOST AND PEAK	DERIVED				THE LOST AND PEAK TIME USED BY THE CONTROL. THIS IS NOT FOR FIELD USE
DE MODIFIER ADDRESS			-1 TO 41943		USED TO ENTER A SPECIFIC DE INSTANCE. SEE <i>COMMUNICATION ON PAGE 151</i>
DE MODIFIER OFFSET			-1 TO 99		USED IN COMBINATION WITH THE DE MODIFIER ADDRESS TO ENTER A SPECIFIC DE INSTANCE. SEE <i>COMMUNICATION ON PAGE 151</i>
P1 BAUD RATE			1200, 4800, 9600, 19200, 38400, 76800		ESTABLISHES THE COMMUNICATION BAUD RATE FOR PORT 1
P1 MANUAL MAC ADDRESS			-1 TO 127		ALLOWS THE MANUAL ENTRANCE OF THE MAC ADDRESS FOR PORT 1. SEE <i>COMMUNICATION ON PAGE 151</i>
P1 PARITY			NONE, EVEN, ODD, IGNORE		DO NOT CHANGE FROM DEFAULT VALUE FOR BACnet
P1 PROTOCOL			BACnet, API		KEEP SETTING ON BACnet
P1 STOP BITS			1-2		DO NOT CHANGE FROM DEFAULT VALUE FOR BACnet
P2 BAUD RATE			1200, 4800, 9600, 19200, 38400, 57600		ESTABLISHES THE COMMUNICATION BAUD RATE FOR PORT 2
P2 MANUAL MAC ADDRESS			-1 TO 127		ALLOWS THE MANUAL ENTRANCE OF THE MAC ADDRESS FOR PORT 2. SEE <i>COMMUNICATION ON PAGE 151</i>
P2 PARITY			NONE, EVEN, ODD, IGNORE		ESTABLISHES THE PARITY FOR COMMUNICATION PORT 2

**6**

**TABLE 51 - SERVICE (CONT'D)**

DISPLAY TEXT	TYPE	ID	VALUE RANGE	LOCATION	DESCRIPTION
P2 PROTOCOL			TERMINAL, MODBUS I/O, MODBUS SERVER, API, MODBUS CLIENT		ESTABLISHES THE PROTOCOL FOR COMMUNICATION PORT 2
P2 STOP BITS			1 - 2		ESTABLISHES THE STOP BIT SETTING FOR COMMUNICATION PORT 2
P3 BAUD RATE			1200, 4800, 9600, 19200, 38400, 57600		ESTABLISHES THE COMMUNICATION BAUD RATE FOR PORT 3
P3 MANUAL MAC ADDRESS			-1 TO 127		ALLOWS THE MANUAL ENTRANCE OF THE MAC ADDRESS FOR PORT 3. SEE <i>COMMUNICATION ON PAGE 151</i>
P3 PARITY			NONE, EVEN, ODD, IGNORE		ESTABLISHES THE PARITY FOR COMMUNICATION PORT 3
P3 PROTOCOL			TERMINAL, MODBUS I/O, MODBUS SERVER, API, MODBUS CLIENT		ESTABLISHES THE PROTOCOL FOR COMMUNICATION PORT 3
P3 STOP BITS			1 - 2		ESTABLISHES THE STOP BIT SETTING FOR COMMUNICATION PORT 3
P4 BAUD RATE			1200, 4800, 9600, 19200, 38400, 57600		ESTABLISHES THE COMMUNICATION BAUD RATE FOR PORT 4
P4 MANUAL MAC ADDRESS			-1 TO 127		ALLOWS THE MANUAL ENTRANCE OF THE MAC ADDRESS FOR PORT 4. SEE <i>COMMUNICATION ON PAGE 151</i>
P4 PARITY			NONE, EVEN, ODD, IGNORE		ESTABLISHES THE PARITY FOR COMMUNICATION PORT 4
P4 PROTOCOL			TERMINAL, MODBUS I/O, MODBUS SERVER, API, MODBUS CLIENT		ESTABLISHES THE PROTOCOL FOR COMMUNICATION PORT 4
P4 STOP BITS			1 - 2		ESTABLISHES THE STOP BIT SETTING FOR COMMUNICATION PORT 4
CONNEXSYS ERROR FEATURE AND DETECTION	DERIVED				NOT FOR FIELD USE

**TABLE 51 - SERVICE (CONT'D)**

DISPLAY TEXT	TYPE	ID	VALUE RANGE	LOCATION	DESCRIPTION
CONNEXSYS ERROR PAGE AND FIELD	DERIVED				NOT FOR FIELD USE
CONNEXSYS ERROR REASON AND VALVE	DERIVED				NOT FOR FIELD USE
REAL TIME PROBLEM STRING	DERIVED				NOT FOR FIELD USE
REAL TIME PROBLEM NUMBER	DERIVED				NOT FOR FIELD USE
REAL TIME PROBLEM	DERIVED				NOT FOR FIELD USE

Following is an example of an Analog Input display that can be viewed from Service Mode. See Table 51 on page 139 for a listing of the Analog Inputs.

<b>SERVICE AI PIO J07-01 XX.X VDC</b>
<b>+ BUILDING STATIC PRES =XX.XXINWC</b>

Following is an example of a DIGITAL Input display that can be viewed from Service Mode. See Table 51 on page 139 for a listing of the Digital Inputs.

<b>SERVICE DI PIO TB08-01</b>
<b>LOCAL STOP RUN</b>

Following is an example of a DIGITAL Output display that can be viewed from Service Mode. The XXX is replaced with OFF or ON in this section. See Table 51 on page 139 for a listing of the Digital Outputs.

<b>SERVICE DO PIO TB03-05</b>
<b>COMPRESSOR 2A OFF</b>

Following is an example of an Analog Output display that can be viewed from Service Mode. See Table 51 on page 139 for a listing of the Analog Outputs

<b>SERVICE AO PIO TB08-01 XX.X VDC</b>
<b>+ SYS 1 FEED VALVE OUTPUT =XXX.X %</b>

**HISTORY**

The History key gives the user access to WARNING and FAULT information. Many operating parameters and states are saved at the time of a fault. The History information can be viewed after entering the Level 2 password.

History Key pressed

<b>WARNING 1</b>	<b>WARNING 2</b>	<b>FAULT 1</b>	<b>FAULT 2</b>	<b>FAULT 3</b>
		Fault 1 Data	Fault 2 Data	Fault 3 Data

When the HISTORY key is pressed, the first active warning will be displayed. If there are not any active warnings, HISTORY 1 is displayed. If there are not any faults, “NO FAULT” will be displayed. Data is not saved for warnings. Data is saved for faults.

When a warning is displayed, the ► key advances to the next warning or HISTORY 1 after the last warning. The ◀ key returns to the previous warning or the highest HISTORY number before the first warning.

When a HISTORY # is displayed, the ► key advances to the next HISTORY # or warning 1 after the last fault. The ◀ key returns to the previous HISTORY # or the highest warning number before the first fault. Buffer number 1 is the most recent and buffer number 10 is the oldest HISTORY # saved. A maximum of 10 HISTORY #s are saved. The ▲ and ▼ key can be used to scroll forwards and backwards through the history buffer data.

The data following the initial History Fault display, is displayed in the same order and with the same message used under the respective menu function:

- Status
- Unit Data
- Cooling
- Supply System
- Comp Sys 1
- Comp Sys 2
- Comp Sys 3

- Heating
- Economizer
- Ventilation
- Exhaust
- Hours/Starts

Pressing the ▼ key from a History Fault display changes the display to the History Section display format. The ► and ◀ keys are used to select a section. Pressing the History or X key returns to the History Fault display. Pressing the ▼ key displays the next parameter in the selected list. From a parameter display, pressing the History or X key returns to the History Fault display. See *Navigation Keys on page 122* for instructions for navigating the parameter display.

For the following example, assume that there were three faults and one warning logged.

First, the History key is pressed to get the password prompt. If a level 2 password is active, this prompt is skipped.

```
HISTORY
ENTER PASSWORD
```

After entering the Level 2 password, the most recent WARNING is displayed.

```
HISTORY WARNING
+ WRN-BUILDING PRS
```

The ► key is pressed to move to the first fault.

```
HISTORY 01 31 OCT 2004 12:45:59 AM
+ LOCKOUT-DUCT PRS XDCR
```

The ► key is pressed to move to the next older fault (fault # 2).

```
HISTORY 02 31 OCT 2004 10:42:39 AM
AUTO RESET-MSAT SENSOR
```

The ► key is pressed to move to the next older fault (fault # 3).

```
HISTORY 03 30 OCT 2004 02:11:23 PM
WRN-BUILDING PRS
```

The ▼ key is pressed to view data saved when fault #3 was detected.

```
HISTORY 03 – STATUS
UNIT-OVERALL STATUS      RUN
```

The ▼ key is pressed to view the second STATUS value.

```
HISTORY 03 – STATUS
CURRENT OPER MODE RUN
```

The ► key is pressed to change to the next data section (UNIT DATA).

```
HISTORY 03 – UNIT DATA
UNIT TYPE      CONSTANT VOLUME
```

The X or HISTORY key is pressed to go back to the fault display.

```
HISTORY 03 30 OCT 2004 02:11:23 PM
WRN-BUILDING PRS
```

From fault display, the X key can be pressed to return to the Power Up Banner display.

## PASSWORD

Passwords are used to allow restricted access to the modification and viewing of certain parameters using the Setpoints, Program, Options, Date/Time, Schedule, Operating Hours / Start Counter, Print, Service, and History menu keys. The menus activated by each of these buttons can only be viewed after an acceptable password is entered. Each parameter is associated with a level of access. Each level of access is associated with a specific password. The access levels available are: Level 1 or Level 2.

- If a parameter is tagged as Level 1, password of 9675 must be entered in order to change the value.
- If a parameter is tagged as Level 2, a password of 9725 must be entered in order to change the value. Entering the Level 2 password will also allow the changing of a Level 1 parameter.

Pressing Setpoints, Program, Options, Date/Time, Schedule, Operating Hours / Start Counter, Print, Service, or History key will take the user to the login prompt. When the user is first presented with the login prompt, the password field will be blank. If the user wishes to change Level 1 or Level 2 parameters, the user must know the appropriate password. At that point, only the parameters changeable under the specific password level will be displayed. For example, if the user presses the Options menu key, and then enters a Level 1 password, the user will be presented with a list of option parameters that have been tagged as Level 1. If the user enters a level 2 password, all parameters are displayed.

The password is entered by pressing the correct sequence of numerical keys (the 0 key through the 9 key), then pressing the ✓ key. As digits are entered, asterisks will be placed in the password field. Once entered, the menu system will compare the password to a list of stored passwords. If the entered password matches one of the stored passwords, the user is allowed access at the specified level, and the display will show the first applicable parameter of the menu list, with the appropriate edit prompts. If the password is not correct, the screen will display “Password Incorrect” for two seconds and then revert back to the Login Prompt. Pressing the X key during password entry will cancel the password entry process and take the user back to the Login Prompt.

Once a password has been accepted, reentry of that password will not be required until either the user presses a menu key other than Setpoints, Program, Options, Date/Time, Schedule, Operating Hours / Start Counter, Print, Service, History or key activity is idle for fifteen minutes. This ensures that the menu system reverts to password protection within an acceptable timeout.

## POWER UP BANNER

When power is first applied to the control panel, the following message will be displayed for two seconds:

The top line displays the copyright message. The bottom line displays the software version, and the present date and time.

The software version number will be in the following formats:

- C.ECO.ZZ.YY (control board released version).
- Where C is the Product Classification and stands for Commercial unit.
- ECO is the Family Code and stands for Series 100 Packaged Rooftop Air Conditioner Control Panel.
- ZZ equals the Product Code.
- YY equals the Version Number.

## COMMUNICATION

The Unit Controller is designed to communicate with a Building Automation System and a printer.

The Building Automation System communication uses BACnet protocol, MS/TP, Modbus I/O, Modbus Server, Modbus Client or Terminal. Other Building Automation system networks can be connected by using a router.

The printer communication uses ASCII protocol and RS-232 hardware.

## Communication Ports

The IPU Control board has four serial communication ports. BACnet MS/TP must use Port 1 and Terminal must use Port 2, which is the RS232 Port. Other protocols may be selected on Ports 2, 3, or 4.

## BACnet Wiring

All BACnet devices are “daisy chained” together using a twisted pair, the (+) is connected to the (+) and the (-) to the (-). The connections on the PORT 1 connector are as follows:

- 1 - 5V
- 2 - Ground
- 3 - Receive (-)
- 4 - Transmit (+)
- 5 - Open

## Device Object Instance (DE)

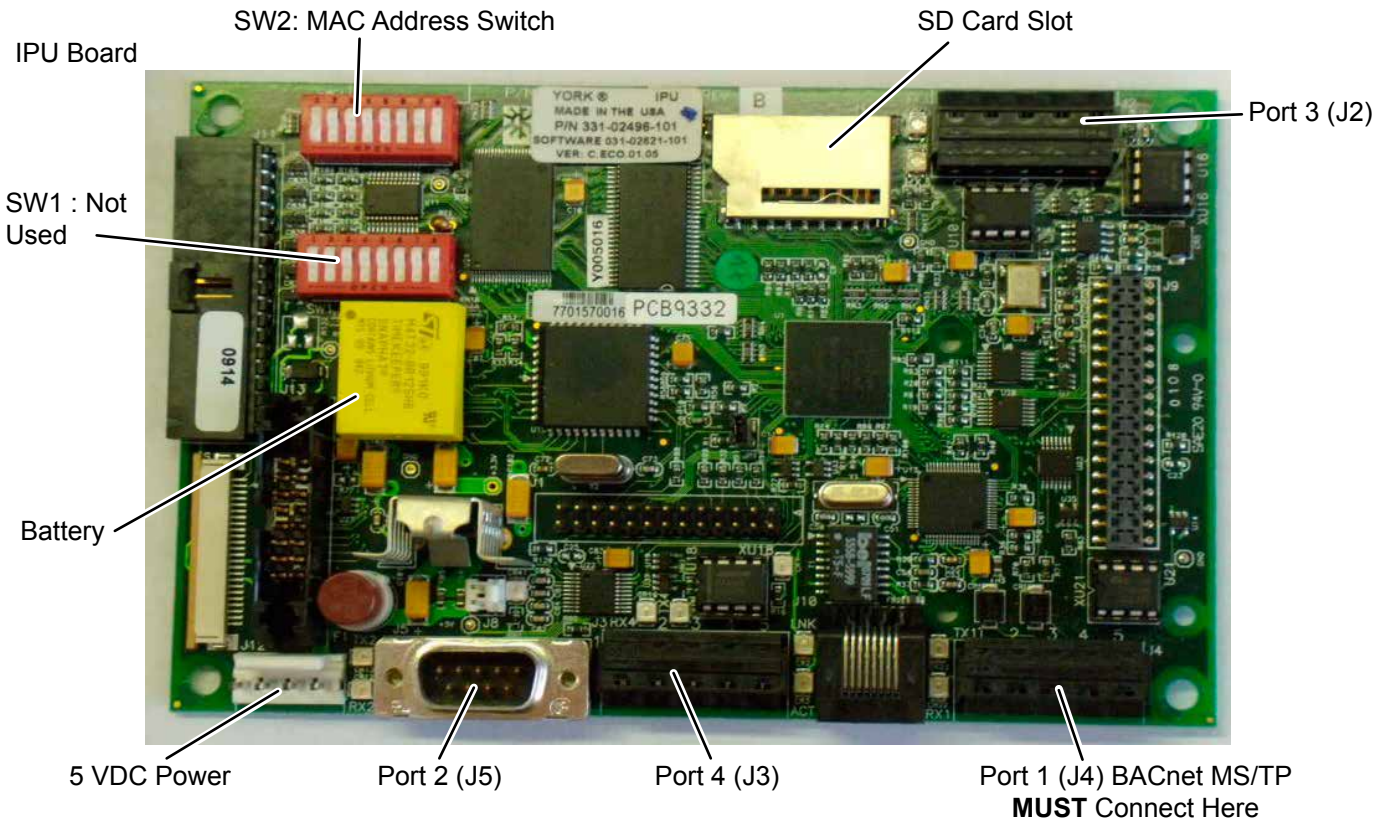
The unit is shipped to automatically establish the DE address after the MAC address is established using the MAC address switches on the IPU or through the User Interface. The default Device Object Instance (DE) would be 23000 plus the MAC address.

The MAC address can be set in two ways using the MAC Address Switches on the IPU or through the Service Key of the User Interface. The 8-way binary switch uses seven of the rockers to set the MAC address. The network address must be between 1 and 127. To determine the node address, add the value of each DIP switch in the ON position as shown in Figure 48. Switch 8 must always be in the ON position to allow terminal operation.

As stated above the MAC address can also be set using the Service Key. Go to parameter “PI MANUAL MAC ACCESS.” Press the ✓ key and enter the MAC address number using the numeric keypad and then press the ✓ key again. The MAC address can be a number from 0 to 127. If the MAC address is entered using the User Interface the control will ignore any values entered through the MAC Address Switches. In order to make the MAC Address switches active again a value of -1 would need to be entered for the “PI MANUAL MAC ACCESS.” In order to use the above procedure to establish the Device Object Instance (DE) the value for “DE MODIFIER OFFSET” MUST BE SET TO -1.”

In most applications the above procedure allows the Device Object Instance (DE) to be established. Some applications may request that the Device Object Instance (DE) be set to a given value. This can be done through the User Interface. To do this you would use the “DE MODIFIER ADDRESS” in conjunction with the “DE MODIFIER OFFSET.” Using this feature,

the Device Object Instance (DE) would be the (“DE MODIFIER ADDRESS” X 100) + “DE MODIFIER OFFSET.” For example, if you wanted a DE address of 2010, the “DE MODIFIER ADDRESS” to 20 and the “DE MODIFIER OFFSET” to 10. The Device Object Instance (DE) is limited to a value between 0 and 4,194,303.



**FIGURE 59 - IPU CONTROL BOARD**

LD20051

The “DE MODIFIER ADDRESS” and the “DE MODIFIER OFFSET” are both set using the Service key of the User Interface. Go to parameter “DE MODIFIER ADDRESS.” Press the ✓ key to enter the DE Modifier Address number using the numeric keypad and then press the ✓ key again. Then go to parameter “DE MODIFIER OFFSET.” Press the ✓ key to enter the DE Modifier Offset number using the numeric keypad and then press the ✓ key again.

### Additional Settings

The following parameters can also be programmed using the SERVICE Key:

- PORT 1
- “P1 BAUD RATE”
- “P1 MANUAL MAC ADDRESS”
- “P1 PARITY”
- “P1 PROTOCOL”
- “P1 STOP BITS”
- PORT 2
- “P2 BAUD RATE”
- “P2 MANUAL MAC ADDRESS”
- “P2 PARITY”
- “P2 PROTOCOL”
- “P2 STOP BITS”
- PORT 3
- “P3 BAUD RATE”
- “P3 MANUAL MAC ADDRESS”
- “P3 PARITY”



- “P3PROTOCOL”
- “P3 STOP BITS”
- PORT 4
- “P4 BAUD RATE”
- “P4 MANUAL MAC ADDRESS”
- “P4 PARITY”
- “P4 PROTOCOL”
- “P4 STOP BITS”

Table 52 on page 153 gives the BACnet name, BACnet Object Type and Instance, and the Modbus Register Address for the available communication points.



*Any time a change is made to the MAC address using the DIP switches or a change to the above communication parameters using the Service Key of the User Interface the main power to the unit must be cycled OFF and back ON to change the value in memory.*

**TABLE 52 - BACNET MS/TP, MODBUS, BACNET IP**

BACNET NAME	USER INTERFACE NAME	READ/ WRITE	BACNET/ OBJECT TYPE AND INSTANCE	MODBUS REGISTER ADDRESS	POINTS LIST DESCRIPTION
ACT_DSP_SP	DUCT STATIC PRESS ACTIVE SP	R	AI01	514	DISPLAYS THE ACTIVE DUCT STATIC PRESS SP ("W.C.)
ACT_MIN_FLOW	ACTIVE MINIMUM AIRFLOW	R	AI02	515	DISPLAYS THE MIN VENTILATION AIR (CFM) SP WHEN THE UNIT HAS AN AIR FLOW MONITORING STATION
ACT_MIN_POS	ACTIVE MINIMUM POSITION	R	AI03	516	DISPLAYS THE MIN OA DAMPER POSITION (%) WHEN THE UNIT IS FIXED MIN VENT CONTROL
ACT_SAT_SP	ACTIVE SUPPLY AIR TEMP SP	R	AI04	517	DISPLAYS THE ACTIVE SUPPLY AIR TEMP SP
ACT_SLAB_CTL	ACTIVE SLAB CONTROL (FLEXSYS ONLY)	R/W	AV77 BV01	1102	ALLOWS THE ACTIVE SLAB CONTROL TO BE TURNED ON/ OFF 0=OFF 1=ON
AMORN_WA_ACT	ADAPTIVE MORNING WARMUP STATUS (ONLY USED WITH INTERNAL TIME CLOCK)	R	BI01		DISPLAYS THE STATUS OF THE ADAPTIVE MORNING WARM-UP
BLD_STAT_PRS	BUILDING PRESSURE CURRENT	R	AI05	518	DISPLAYS THE CURRENT BUILDING PRESS ("W.C.)
BULD_PRES_SP	BLDG PRESS SP	R/W	AV01	1026	DISPLAYS THE ACTIVE BUILDING PRESSURE SP ("W.C.)

**TABLE 52 - BACnet MS/TP, MODBUS, BACnet IP (CONT'D)**

BACNET NAME	USER INTERFACE NAME	READ/ WRITE	BACNET/ OBJECT TYPE AND INSTANCE	MODBUS REGISTER ADDRESS	POINTS LIST DESCRIPTION
BYPASS_DAMPER	BYPASS DAMPER POSITION (FLEXSYS ONLY)	R	AI06	519	DISPLAYS THE ACTUAL BYPASS DAMPER POSITION (%)
CO2_1_OUT	CO2 LEVEL OF THE OUTSIDE AIR	R	AI07	520	DISPLAYS THE ACTUAL OA AIR CO2 (PPM)
CO2_2_IN	CO2 LEVEL OF THE INSIDE AIR	R	AI08	521	DISPLAYS THE ACTUAL RA AIR CO2 (PPM)
CO2_INSIDE	CO2 LVL INSIDE VALUE BAS	R/W	AV43	1168	A BAS ENTERED VALUE FOR THE INSIDE CO2 LEVEL. "CO2 LVL INSIDE BAS" MUST BE ENABLED USING THE SERVICE KEY IN ORDER TO USE THIS POINT (CO2)
CO2_OFFSET	CO2 OFFSET SP	R/W	AV02	1027	DISPLAYS THE VALUE (PPM) THAT THE INDOOR CO2 MUST RISE ABOVE THE OUTSIDE CO2 TO ACTIVATE DEMAND VENTILATION
COL/HEAT_FLT	COOLING/ HEATING FAULT STATUS	R	BI02	1283	DISPLAYS THE STATUS OF THE COOLING OR HEATING SYSTEM. 0=NO FAULT 1=FAULT
COMFORT_VENT	COMFORT VENTILATION (CONSTANT VOLUME)	R/W	AV78 BV02	1103	DISPLAYS THE STATUS OF THE COMFORT VENT OPTION AND ALLOW IT TO BE TURNED ON/ OFF: 0=OFF 1=ON
COMP_1A	COMPRESSOR 1A STATUS	R	BI03	1284	DISPLAYS THE STATUS OF COMP 1A: 0=OFF 1=ON
COMP_1A_OPER	COMP 1A OPERATING HRS	R	AI09	522	DISPLAYS THE OPERATING HRS OF COMP 1A
COMP_1B	COMPRESSOR 1B STATUS	R	BI04	1285	DISPLAYS THE STATUS OF COMP 1B: 0=OFF 1=ON
COMP_1B_OPER	COMP 1B OPERATING HRS	R	AI10	523	DISPLAYS THE OPERATING HRS OF COMP 1B
COMP_2A	COMPRESSOR 2A STATUS	R	BI05	1286	DISPLAYS THE STATUS OF COMP 2A: 0=OFF 1=ON
COMP_2A_OPER	COMP 2A OPERATING HRS	R	AI11	524	DISPLAYS THE OPERATING HRS OF COMP 2A
COMP_2B	COMPRESSOR 2B STATUS	R	BI06	1287	DISPLAYS THE STATUS OF COMP 2B: 0=OFF 1=ON
COMP_2B_OPER	COMP 2B OPERATING HRS	R	AI12	525	DISPLAYS THE OPERATING HRS OF COMP 2B
COMP_3A	COMPRESSOR 3A STATUS (70-150 TON ONLY)	R	BI07	1288	DISPLAYS THE STATUS OF COMP 3A: 0=OFF 1=ON

**TABLE 52 - BACnet MS/TP, MODBUS, BACnet IP (CONT'D)**

BACNET NAME	USER INTERFACE NAME	READ/ WRITE	BACNET/ OBJECT TYPE AND INSTANCE	MODBUS REGISTER ADDRESS	POINTS LIST DESCRIPTION
COMP_3A_OPER	COMP 3A OPERATING HRS (70-150 TON ONLY)	R	AI13	526	DISPLAYS THE OPERATING HRS OF COMP 3A
COMP_3B	COMPRESSOR 3B STATUS (70-150 TON ONLY)	R	BI08	1289	DISPLAYS THE STATUS OF COMP 3B: 0=OFF 1=ON
COMP_3B_OPER	COMP 3B OPERATING HRS (70-150 TON ONLY)	R	AI14	527	DISPLAYS THE OPERATING HRS OF COMP 3B
COMP_LPCO_1	SAFETY INPUT LPCO CKT 1 STATUS	R	BI09	1290	DISPLAYS THE STATUS OF THE LOW PRESS SWITCH ON CKT 1: 0=FAULT 1=NO FAULT
COMP_LPCO_2	SAFETY INPUT LPCO CKT 2 STATUS	R	BI10	1291	DISPLAYS THE STATUS OF THE LOW PRESS SWITCH ON CKT 2: 0=FAULT 1=NO FAULT
COMP_LPCO_3	SAFETY INPUT LPCO CKT 3 STATUS (70-150 TON ONLY)	R	BI11	1292	DISPLAYS THE STATUS OF THE LOW PRESS SWITCH ON CKT 3: 0=FAULT 1=NO FAULT
COMP_STAT_1	SAFETY CHAIN CKT 1 STATUS	R	BI12	1293	DISPLAYS THE STATUS OF CKT 1 SAFETY CHAIN: 0=FAULT 1=NO FAULT
COMP_STAT_2	SAFETY CHAIN CKT 2 STATUS	R	BI13	1294	DISPLAYS THE STATUS OF CKT 2 SAFETY CHAIN: 0=FAULT 1=NO FAULT
COMP_STAT_3	SAFETY CHAIN CKT 3 STATUS (70-150 TON ONLY)	R	BI14	1295	DISPLAYS THE STATUS OF CKT 3 SAFETY CHAIN: 0=FAULT 1=NO FAULT
COND_FAN_1A	COND FAN 1A/1 STATUS	R	BI15	1296	DISPLAYS THE STATUS OF COND FAN 1A/1: 0=OFF 1=ON
COND_FAN_1B	COND FAN 1B/2 STATUS	R	BI16	1297	DISPLAYS THE STATUS OF COND FAN 1B/2: 0=OFF 1=ON
COND_FAN_2A	COND FAN 2A/3 STATUS	R	BI17	1298	DISPLAYS THE STATUS OF COND FAN 2A/3: 0=OFF 1=ON
COND_FAN_2B	COND FAN 2B/4 STATUS	R	BI18	1299	DISPLAYS THE STATUS OF COND FAN 2B/4: 0=OFF 1=ON
COND_FAN_3A	COND FAN 3A/5 STATUS (70-150 TON ONLY)	R	BI19	1300	DISPLAYS THE STATUS OF COND FAN 3A/5: 0=OFF 1=ON
COND_FAN_3B	COND FAN 3B/6 STATUS (70-150 TON ONLY)	R	BI20	1301	DISPLAYS THE STATUS OF COND FAN 3B/6: 0=OFF 1=ON
COND_FAN_SPD	COND FAN SPEED	R	AI15	528	NOT USED AT THIS TIME. FOR FUTURE USE

**6**

**TABLE 52 - BACnet MS/TP, MODBUS, BACnet IP (CONT'D)**

BACNET NAME	USER INTERFACE NAME	READ/ WRITE	BACNET/ OBJECT TYPE AND INSTANCE	MODBUS REGISTER ADDRESS	POINTS LIST DESCRIPTION
CONTINU_VENT	CONTINUOUS VENTILATION (CONSTANT VOLUME)	R/W	AV79 BV03	1104	DISPLAYS THE STATUS OF THE CONTINUOUS VENTILATION OPTION AND ALLOWS FOR IT TO BE TURNED ON/OFF: 0=OFF 1=ON
DCT_ST_PR_RT	DUCT STATIC PRESS RESET	R	AI16	529	DISPLAYS THE STATUS OF THE HARDWIRED DUCT STATIC RESET VALUE TO CTB1 (%)
DCT_STAT_PRS	DUCT STATIC PRESS CURRENT (VAV or FLEXSYS)	R	AI17	530	DISPLAYS THE ACTUAL DUCT STATIC PRESS. (" W.C.)
DEW_PNT_RST	DEW POINT RESET (FLEXSYS)	R/W	AV80 BV04	1105	ALLOWS THE DEW POINT RESET FEATURE TO BE TURNED ON/OFF: 0=OFF 1=ON
DSP_HI_LIMIT	DUCT STATIC RESET HIGH SP (VAV or FLEXSYS)	R/W	AV03	1028	DISPLAYS THE DUCT STATIC HIGH SP ("W.C.)
DSP_LO_LIMIT	DUCT STATIC RESET LOW SP (VAV or FLEXSYS)	R/W	AV04	1029	DISPLAYS THE DUCT STATIC LOW SP ("W.C.)
DSP_RST_BAS	DUCT STATIC PRESS RESET BAS (VAV or FLEXSYS)	R/W	AV05	1030	A BAS VALUE THAT CAUSES THE RESET OF THE DUCT STATIC PRESS SP BETWEEN TO HIGH AND LOW VALUES. "DUCT PRES RST BAS" MUST BE ENABLED THROUGH THE SERVICE KEY TO USE THIS POINT (%)
ECON_ME_USED	ECON METHOD ACTIVE	R	AI18	531	DISPLAYS THE STATUS OF THE ACTIVE ECONOMIZER MODE: 1=DRY BULB 2=SINGLE ENTHALPY 3=DUAL ENTHALPY 4=BEST METHOD AVAIL
ECON_STATUS	ECON SYSTEM STATUS	R	AI19	532	DISPLAYS THE STATUS OF THE ECONOMIZER: 1=INSTALLED AND ACTIVE 2=NOT INSTALLED 3=DISABLED
ECONO_INSTAL	ECONOMIZER SYSTEM	R/W	AV81 BV05	1106	ALLOWS THE ECONOMIZER FEATURE TO BE TURNED ON/ OFF: 0=OFF 1=ON
ECONO_METHOD	ECON METHOD TO USE	R/W	AV06	1031	ALLOWS FOR THE SELECTION OF THE ECONOMIZER METHOD TO USE: 1=DRY BULB 2=SINGLE ENTHALPY 3=DUAL ENTHALPY 4=BEST METHOD AVAIL

**TABLE 52 - BACnet MS/TP, MODBUS, BACnet IP (CONT'D)**

BACNET NAME	USER INTERFACE NAME	READ/ WRITE	BACNET/ OBJECT TYPE AND INSTANCE	MODBUS REGISTER ADDRESS	POINTS LIST DESCRIPTION
EL_AIR_TMP_H	EVAP LEAVING AIR TEMP HIGH SP (FLEXSYS)	R/W	AV07	1032	DISPLAYS THE ACTIVE SP FOR THE HIGH EVAP LEAVING AIR TEMP. THIS IS THE SP THE COMPRESSORS ARE CONTROLLED TO (OCC COOLING W/ BYPASS)
EL_AIR_TMP_L	EVAP LEAVING AIR TEMP LOW SP (FLEXSYS)	R/W	AV08	1033	DISPLAYS THE ACTIVE SP FOR THE LOW EVAP LEAVING AIR TEMP. THIS IS THE SP THE COMPRESSORS ARE CONTROLLED TO (OCC COOLING W/ BYPASS)
EVAP_AIR_TMP	FLEXSYS EVAP TEMP CURRENT (FLEXSYS)	R	AI20	533	DISPLAYS THE ACTUAL TEMP OF THE AIR LEAVING THE EVAPORATOR (OCC COOLING W/ BYPASS)
EXH_DAMPER/VFD	EXHAUST DAMPER BAS CONTROL	R/W	AV52	NA*	ALLOWS FOR THE CONTROL OF THE EXHAUST FAN SPEED OR MODULATING DAMPER (RETURN FAN). 0 TO 100% FOR BOTH APPLICATIONS.
EXH_FAN_STAT	EXHAUST FAN STATUS	R	BI21	1302	DISPLAYS THE STATUS OF THE EXHAUST FAN PROVING CIRCUIT: 0=OPEN 1=CLOSED
EXHAUST_FAN	EXHAUST FAN OUTPUT STATUS	R	BI22	1303	DISPLAYS THE STATUS OF THE EXHAUST FAN OUTPUT: 0=OFF 1=ON
EXHAUST_OUT	EXHAUST DAMPER POSITION	R	AI21	534	DISPLAYS THE CONTROL OUTPUT TO THE EXH DAMPER (%)
FAN_FAULT	FAN FAULT STATUS	R	BI23	1304	DISPLAYS THE STATUS OF THE SUPPLY, EXHAUST or RETURN FAN FAULT: 0=NO FAULT 1=FAULT
FAN_G	FAN (G) STATUS	R	BI24	1305	DISPLAYS THE STATUS OF THE FAN (G) INPUT; EITHER HARDWIRED (CTB1) or COMMUNICATED (BAS): 0=OFF 1=ON
FAN_G_BAS	FAN (G) BAS	R/W	AV82 BV06	1107	A BAS COMMAND THAT ALLOWS THE FAN (G) INPUT TO BE TURNED ON/OFF: 0=OFF 1=ON
FILTER_STATS	FILTER STATUS	R	BI25	1306	DISPLAYS THE STATUS OF THE DIRTY FILTER INPUT: 0=NO FAULT 1=FAULT

**6**

**TABLE 52 - BACnet MS/TP, MODBUS, BACnet IP (CONT'D)**

BACNET NAME	USER INTERFACE NAME	READ/ WRITE	BACNET/ OBJECT TYPE AND INSTANCE	MODBUS REGISTER ADDRESS	POINTS LIST DESCRIPTION
FURN_OUT_1	ELECT HEAT STAGE 1 STATUS STAGED GAS FURN 1 LO STATUS MOD GAS FURN 1A LOW STATUS	R	BI26	1307	DISPLAYS THE STATUS OF THE CONTROL OUTPUT TO THE INDICATED HEAT SECTION: 0=OFF 1=ON
FURN_OUT_2	ELECT HEAT STAGE 2 STATUS STAGED GAS FURN 1 HIGH STATUS MOD GAS FURN 1A HIGH STATUS	R	BI27	1308	DISPLAYS THE STATUS OF THE CONTROL OUTPUT TO THE INDICATED HEAT SECTION: 0=OFF 1=ON
FURN_OUT_3	ELECT HEAT STAGE 3 STATUS STAGED GAS FURN 2 LOW STATUS MOD GAS FURN 2 LOW STATUS	R	BI28	1309	DISPLAYS THE STATUS OF THE CONTROL OUTPUT TO THE INDICATED HEAT SECTION: 0=OFF 1=ON
FURN_OUT_4	ELECT HEAT STAGE 4 STATUS STAGED GAS FURN 2 HIGH STATUS MOD GAS FURN 2 HIGH STATUS	R	BI29	1310	DISPLAYS THE STATUS OF THE CONTROL OUTPUT TO THE INDICATED HEAT SECTION: 0=OFF 1=ON
FURN_OUT_5	ELECT HEAT STAGE 5 STATUS STAGED GAS FURN 3 LOW STATUS MOD GAS FURN 3 LOW STATUS	R	BI30	1311	DISPLAYS THE STATUS OF THE CONTROL OUTPUT TO THE INDICATED HEAT SECTION: 0=OFF 1=ON
FURN_OUT_6	ELECT HEAT STAGE 6 STATUS STAGED GAS FURN 3 HIGH STATUS MOD GAS FURN 3 HIGH STATUS	R	BI31	1312	DISPLAYS THE STATUS OF THE CONTROL OUTPUT TO THE INDICATED HEAT SECTION: 0=OFF 1=ON
FURN_OUT_7	ELECT HEAT STAGE 7 STATUS MOD GAS FURN 1B STATUS	R	BI32	1313	DISPLAYS THE STATUS OF THE CONTROL OUTPUT TO THE INDICATED HEAT SECTION: 0=OFF 1=ON
HEAT_ENABLE	HEATING SYSTEM	R/W	AV83 BV07	1108	A BAS COMMAND THAT ALLOWS THE HEATING FUNCTION TO BE TURNED ON/OFF: 0=ENABLED 1=DISABLED

**TABLE 52 - BACnet MS/TP, MODBUS, BACnet IP (CONT'D)**

BACNET NAME	USER INTERFACE NAME	READ/ WRITE	BACNET/ OBJECT TYPE AND INSTANCE	MODBUS REGISTER ADDRESS	POINTS LIST DESCRIPTION
HEAT_ENT_TEMP	HEAT ENTERING TEMP	R	AI22	535	DISPLAYS THE ACTUAL TEMP OF THE AIR ENTERING THE ELECT, STAGED GAS, OR MOD GAS HEAT SECTIONS
HEAT_STAGES	ELECTRIC HEAT STAGES or GAS HEAT STAGES	R	AI23	536	DISPLAYS THE NUMBER OF ELECT OR STAGED GAS HEAT STAGES AVAILABLE
HEAT_VACTION	HW VALVE ACTION	R/W	AV84 BV08	1109	A BAS COMMAND THAT ALLOWS THE HOT WATER/STEAM VALVE ACTION TO BE CHANGED: 0=DIRECT 1=REVERSE
HEATING_SAT	HEATING SUPPLY AIR TEMP SP (VAV or FLEXSYS)	R/W	AV09	1034	DISPLAYS THE ACTIVE SUPPLY AIR TEMP SP FOR HEATING
HEATING_VLV	HEATING VALVE	R	AI24	537	DISPLAYS THE OUPUT FROM THE CONTROL TO A HW/STEAM VALVE or MOD GAS HEAT VALVE (%)
HW_FRZ_STAT	HW/STEAM COIL FREEZESTAT STATUS	R	BI33	1314	DISPLAYS THE STATUS OF THE FREEZESTAT ON UNITS WITH HW/STEAM HEAT: 0=NO FAULT 1-FAULTED
LOCAL_STOP	LOCAL STOP STATUS	R	BI34	1315	DISPLAYS THE STATUS OF THE 24VAC INPUT TO THE CONTROL BOARD THROUGH THE SD TERMINAL AND/OR THE UNIT ON/OFF SWITCH
MAX_BYPASS	MAXIMUM BYPASS SP (FLEXSYS)	R/W	AV10	1035	DISPLAYS THE MAX SETTING FOR THE BYPASS DAMPER
MAX_FLOW_DV	OUTSIDE AIR MAX FLOW SP	R/W	AV11	1036	DISPLAYS THE MAX AIRFLOW FOR DEMAND VENTILATIONWITH AN AIRFLOW STATION (CFM)
MECH_LCK_TMP	MECH COOLING LOCKOUT SP	R/W	AV12	1037	DISPLAYS THE MIN OA TEMP AT WHICH MECH COOLING IS ALLOWED TO OPERATE
MIN_FLOW_DV	OUTSIDE AIR MIN FLOW SP	R/W	AV13	1038	DISPLAYS THE MIN AIRFLOW FOR DEMAND VENTILATION WITH AN AIRFLOW STATION (CFM)
MIN_OA_FLO	MINIMUM OA FLOW SETPOINT	R/W	AV51	1076	DISPLAYS THE MIN OUTSIDE AIRFLOW ACTIVE SETPOINT FOR TEKAIR MEASURING STATION (TEKAIR FULL IAQ). VENTILATION NEEDS TO BE USER ENABLED (CFM)

**6**

**TABLE 52 - BACnet MS/TP, MODBUS, BACnet IP (CONT'D)**

BACNET NAME	USER INTERFACE NAME	READ/ WRITE	BACNET/ OBJECT TYPE AND INSTANCE	MODBUS REGISTER ADDRESS	POINTS LIST DESCRIPTION
MIXD_SAT_LIM	MX SUPPLY AIR TEMP SP (FLEXSYS)	R/W	AV14	1039	DISPLAYS THE ACTIVE MIXED AIR TEMP SP (OCC COOLING W/O BYPASS-COMPRESSOR CONTROL)  (OCC COOLING W/ BYPASS-DAMPER CONTROL)
MORN_WARM_UP	MORNING WARM UP	R/W	AV85 BV09	1110	A BAS COMMAND THAT ALLOWS MORNING WARM-UP TO BE ENABLED/DISABLED: 0=ENABLED 1-DISABLED
MORN_WUP_CMD	MORN WARMUP COMMAND	R/W	AV86 BV10	1111	A BAS COMMAND THAT STARTS/ STOPS MORNING WARM-UP: 0=OFF 1=ON
MORN_WUP_RAT	HEATING RET AIR TEMP SP (VAV or FLEXSYS)	R/W	AV15	1040	DISPLAYS THE ACTIVE R/A TEMP SP FOR HEATING
NIGHT_SETBAC	NIGHT SETBACK FOR HEATING	R/W	AV87 BV11	1112	A BAS COMMAND THAT ALLOWS NIGHT SET BACK TO BE TURNED ON/OFF: 0=OFF 1=ON
OA_DAMP_POS1	OA DAMPER MINIMUM POSITION	R/W	AV16	1041	DISPLAYS THE ACTIVE SP FOR THE MIN OA DAMPER WHEN USING FIXED MINIMUM VENTILATION AND THE SUPPLY FAN VFD IS AT 100%
OA_DAMP_POS2	OA DAMPER MAXIMUM POSITION	R/W	AV17	1042	DISPLAYS THE MAX POSITION FOR THE OA DAMPER WHEN USING FIXED MINIMUM VENTILATION AND THE SUPPLY FAN VFD IS AT 50%
OA_DAMPER	OA DAMPER POSITION CURRENT	R	AI25	538	DISPLAYS THE POSITION OF THE OA DAMPER (%)
OA_ENTH_LIMIT	OA ENTHALPY SP	R/W	AV18	1043	DISPLAYS THE MAX ENTHALPY SP FOR USING OA FOR COOLING (BTU/LB) SINGLE or DUAL ENTHALPY
OA_ENTHALPY	OA ENTHALPY	R	AI26	539	DISPLAYS THE CURRENT OA ENTHALPY (BTU/LB)
OA_FLO_PRS_1	OA FLOW PRESS 1	R	AI27	540	NOT USED
OA_FLO_PRS_2	OA FLOW PRESS 2	R	AI28	541	NOT USED
OA_FLOW_1	IAQ DAMPER AIR FLOWS OA FLOW 1	R	AI61	574	DISPLAYS THE AIR FLOW THROUGH A TEK-AIR FULL IAQ AIR MEASURING STATION (CFM)



**TABLE 52 - BACnet MS/TP, MODBUS, BACnet IP (CONT'D)**

BACNET NAME	USER INTERFACE NAME	READ/ WRITE	BACNET/ OBJECT TYPE AND INSTANCE	MODBUS REGISTER ADDRESS	POINTS LIST DESCRIPTION
OA_FLOW_2	IAQ DAMPER AIR FLOWS OA FLOW 2	R	AI62	575	NOT USED
OA_FLOW_TOTL	OA FLOW TOTAL	R	AI63	576	DISPLAYS THE TOTAL AIR FLOW THRU A TEK-AIR FULL IAQ AIR MEASURING STATION (CFM)
OA_REL_HUMID	OA HUMIDITY	R	AI29	542	DISPLAYS THE CURRENT OA RELATIVE HUMIDITY (%)
OA_TEMP	OA TEMPERATURE	R	AI30	543	DISPLAYS THE CURRENT OA TEMP
OAT_HIGH_SAT	OA TEMP SP FOR HI SUPPLY AIR TEMP (VAV, AND ONLY IF SAT RESET METHOD IS OUTSIDE AIR)	R/W	AV19	1044	DISPLAYS THE OA TEMP SP USED FOR SWITCHING TO THE HIGH SUPPLY AIR TEMP SP
OAT_LOW_SAT	OA TEMP SP FOR LO SUPPLY AIR TEMP (VAV, AND ONLY IF SAT REST METHOD IS OUTSIDE AIR)	R/W	AV20	1045	DISPLAYS THE OA TEMP SP USED FOR SWITCHING TO THE LOW SUPPLY AIR TEMP SP
OCC_MODE	OCCUPANCY MODE STATUS	R	BI35	1316	DISPLAYS THE OCC/UNOCC STATUS WITH HARDWIRED, COMMUNICATED, or INTERNAL CLOCK SCHEDULE INPUT: (ENA=ENABLED/OCC DIS=DISABLED/UNOCC)
OCC_STATE	OCCUPANCY STATE STATUS	R	BI36	1317	DISPLAYS THE STATUS OF THE HARDWIRED INPUT: (ENA=ENABLED/OCC DIS=DISABLED/UNOCC)
OCC_ZN_COOL	OCC ZONE COOLING SP	R/W	AV21	1046	DISPLAYS THE ACTIVE OCCUPIED ZONE COOLING SP
OCC_ZN_HEAT	OCC ZONE HEATING SP	R/W	AV22	1047	DISPLAYS THE ACTIVE OCCUPIED ZONE HEATING SP
OCCUPNCY_CMD	OCCUPANCY COMMAND	R/W	AV88 BV12	1113	A BAS COMMAND THAT ALLOWS THE UNIT TO BE PLACED IN THE OCC/UNOCC MODE: (0=UNOCC 1=OCC)
PRS_1_DISCH	DISCH PRESS CKT 1	R	AI31	544	DISPLAYS THE CURRENT DISCH PRESS OF CKT 1 (PSIG)
PRS_1_SUCT	SUCT PRESS CKT 1	R	AI32	545	DISPLAYS THE CURRENT SUCT PRESS OF CKT 1 (PSIG)
PRS_2_DISCH	DISCH PRESS CKT 2	R	AI33	546	DISPLAYS THE CURRENT DISCH PRESS OF CKT 2 (PSIG)

**6**

**TABLE 52 - BACnet MS/TP, MODBUS, BACnet IP (CONT'D)**

BACNET NAME	USER INTERFACE NAME	READ/ WRITE	BACNET/ OBJECT TYPE AND INSTANCE	MODBUS REGISTER ADDRESS	POINTS LIST DESCRIPTION
PRS_2_SUCTION	SUCT PRESS CKT 2	R	AI34	547	DISPLAYS THE CURRENT SUCT PRESS OF CKT 2 (PSIG)
PRS_3_DISCH	DISCH PRESS CKT 3 (70-150 TON ONLY)	R	AI35	548	DISPLAYS THE CURRENT DISCH PRESS OF CKT 3 (PSIG)
PRS_3_SUCT	SUCT PRESS CKT 3 (70-150 TON ONLY)	R	AI36	549	DISPLAYS THE CURRENT SUCT PRESS OF CKT 3 (PSIG)
PUMP_DOWN	PUMP DOWN	R/W	AV89 BV13	1114	A BAS COMMAND THAT ALLOWS THE PUMP DOWN FEATURE TO BE TURNED ON/OFF: (0=ON 1=OFF)
PUMP_DOWN_1	PUMP DOWN LLSV 1 STATUS	R	BI37	1318	DISPLAYS THE STATUS OF THE OUTPUT TO THE CKT 1 LIQ LINE SOLENOID VLV: (0=ON 1=OFF)
PUMP_DOWN_2	PUMP DOWN LLSV 2 STATUS	R	BI38	1319	DISPLAYS THE STATUS OF THE OUTPUT TO THE CKT 2 LIQ LINE SOLENOID VLV: (0=ON 1=OFF)
PUMP_DOWN_3	PUMP DOWN LLSV 3 STATUS (70-150 TON ONLY)	R	BI39	1320	DISPLAYS THE STATUS OF THE OUTPUT TO THE CKT 3 LIQ LINE SOLENOID VLV: (0=ON 1=OFF)
RA_DIFF_BAS	RETURN AIR DIFF SP BAS (FLEXSYS)	R/W	AV42	1067	DISPLAYS THE ACTIVE TEMP SP THAT CAUSES THE UNIT TO SWITCH FROM COOLING w/o BYPASS TO COOLING w/BYPASS
RAT_COOL_SP	COOLING RETURN AIR TEMP SP (VAV or FLEXSYS)	R/W	AV23	1048	DISPLAYS THE ACTIVE RETURN AIR TEMP SP FOR COOLING
RAT_HIGH_SAT	RA TEMP SP FOR HI SUPPLY AIR TEMP (VAV, AND ONLY IF SAT RESET METHOD IS RETURN AIR)	R/W	AV24	1049	DISPLAYS THE RA TEMP SP USED FOR SWITCHING TO THE HIGH SUPPLY AIR TEMP SP
RAT_LOW_SAT	RA TEMP SP FOR LO SUPPLY AIR TEMP (VAV, AND ONLY IF SAT RESET METHOD IS RETURN AIR)	R/W	AV25	1050	DISPLAYS THE RA TEMP SP USED FOR SWITCHING TO THE LOW SUPPLY AIR TEMP SP
RDY_RUN_C1A	READY TO RUN COMP 1A STATUS	R	BI40	1321	DISPLAYS THE STATUS OF COMP 1A READY TO RUN IF COMP IS OFF: (YES/NO)

**TABLE 52 - BACnet MS/TP, MODBUS, BACnet IP (CONT'D)**

BACNET NAME	USER INTERFACE NAME	READ/ WRITE	BACNET/ OBJECT TYPE AND INSTANCE	MODBUS REGISTER ADDRESS	POINTS LIST DESCRIPTION
RDY_RUN_C1B	READY TO RUN COMP 1B STATUS	R	BI41	1322	DISPLAYS THE STATUS OF COMP 1B READY TO RUN IF THE COMP IS OFF: (YES/NO)
RDY_RUN_C2A	READY TO RUN COMP 2A STATUS	R	BI42	1323	DISPLAYS THE STATUS OF COMP 2A READY TO RUN IF THE COMP IS OFF: (YES/NO)
RDY_RUN_C2B	READY TO RUN COMP 2B STATUS	R	BI43	1324	DISPLAYS THE STATUS OF COMP 2B READY TO RUN IF THE COMP IS OFF: (YES/NO)
RDY_RUN_C3A	READY TO RUN COMP 3A STATUS (70-150 TON ONLY)	R	BI44	1325	DISPLAYS THE STATUS OF COMP 3A READY TO RUN IF THE COMP IS OFF: (YES/NO)
RDY_RUN_C3B	READY TO RUN COMP 3B STATUS (70-150 TON ONLY)	R	BI45	1326	DISPLAYS THE STATUS OF COMP 3B READY TO RUN IF THE COMP IS OFF: (YES/NO)
RDY_STOP_C1A	READY TO STOP COMP 1A STATUS	R	BI46	1327	DISPLAYS THE STATUS OF COMP 1A READY TO STOP IF OPERATING: (YES/NO)
RDY_STOP_C1B	READY TO STOP COMP 1B STATUS	R	BI47	1328	DISPLAYS THE STATUS OF COMP 1B READY TO STOP IF OPERATING: (YES/NO)
RDY_STOP_C2A	READY TO STOP COMP 2A STATUS	R	BI48	1329	DISPLAYS THE STATUS OF COMP 2A READY TO STOP IF OPERATING: (YES/NO)
RDY_STOP_C2B	READY TO STOP COMP 2B STATUS	R	BI49	1330	DISPLAYS THE STATUS OF COMP 2B READY TO STOP IF OPERATING: (YES/NO)
RDY_STOP_C3A	READY TO STOP COMP 3A STATUS (70-150 TON ONLY)	R	BI50	1331	DISPLAYS THE STATUS OF COMP 3A READY TO STOP IF OPERATING: (YES/NO)
RDY_STOP_C3B	READY TO STOP COMP 3B STATUS (70-150 TON ONLY)	R	BI51	1332	DISPLAYS THE STATUS OF COMP 3B READY TO STOP IF OPERATING: (YES/NO)
RET_AIR_BY_S	RETURN AIR BYPASS ACTIVE SP	R	AI37	550	DISPLAYS THE VALUE (%) FOR THE CURRENT SP OF THE RA BYPASS DAMPER ONN A FLEXSYS UNIT
RET_AIR_ENTH	RETURN AIR ENTHALPY	R	AI38	551	DISPLAYS THE ACTUAL RA ENTHALPY (BTU/LB)
RET_AIR_HUMD	RETURN AIR HUMIDITY	R	AI39	552	DISPLAYS THE ACTUAL RA RELATIVE HUMIDITY (%)
RET_AIR_TEMP	RETURN AIR TEMP CURRENT	R	AI40	553	DISPLAYS THE ACTUAL RA TEMP (°F)

**TABLE 52-** BACnet MS/TP, MODBUS, BACnet IP (CONT'D)

BACNET NAME	USER INTERFACE NAME	READ/ WRITE	BACNET/ OBJECT TYPE AND INSTANCE	MODBUS REGISTER ADDRESS	POINTS LIST DESCRIPTION
RET_FAN_OUT	EXHAUST/ RETURN FAN VFD	R	AI41	554	DISPLAYS THE OUTPUT FROM THE CONTROL TO THE EXH OR RET FAN VFD (%)
RET_FAN_PRES	RETURN FAN PRESSURE CURRENT	R	AI42	555	DISPLAYS THE ACTUAL PRESSURE THAT IS USED TO CONTROL THE RETURN FAN SPEED ("W.C.)
RET_FAN_STAT	RETURN FAN STATUS	R	BI52	1333	DISPLAYS THE STATUS OF THE RETURN FAN RUN VERIFICATION CIRCUIT (0=STOP/VERIFICATION CKT OPEN, 1=RUN/VERIFICATION CKT CLOSED)
RST_ENT_BAS	RESET ENTHALPY SP BAS	R/W	AV41	1066	DISPLAYS THE RA ENTHALPY SP WHICH CAUSES THE UNIT TO SWITCH FROM THE EVAP LEAVING HIGH SP TO THE EVAP LEAVING LOW SP
SAT_HIGH_LIM	SUPPLY AIR TEMP HI SP	R/W	AV26	1051	DISPLAYS THE UPPER LIMIT FOR THE SUPPLY AIR TEMP SP ON A VAV UNIT (°F)
SAT_LOW_LIM	SUPPLY AIR TEMP LO SP	R/W	AV27	1052	DISPLAYS THE LOWER LIMIT FOR THE SUPPLY AIR TEMP SP ON A VAV UNIT (°F)
SAT_RST_BAS	SUPPLY AIR TEMP RESET BAS	R/W	AV28	1053	DISPLAYS THE ANALOG INPUT FROM THE BAS SYSTEM THAT ALLOWS THE RESET OF THEIR ACTIVE SUPPLY AIR TEMP SP. 0 USES SAT HIGH SP AND 5 USES SAT LOW SP. "SAT RST BAS" MUST BE ENABLED IN THE SERVICE MENU FOR THIS POINT TO FUNCTION
SAT_SUC_TMP1	SATURATED SUCTION TEMP CKT 1	R	AI43	556	DISPLAYS THE SATURATION TEMP OF SYSTEM 1 SUCTION GAS BASED ON SYSTEM 1 SUCTION PRESS (°F)
SAT_SUC_TMP2	SATURATED SUCTION TEMP CKT 2	R	AI44	557	DISPLAYS THE SATURATION TEMP OF SYSTEM 2 SUCTION GAS BASED ON SYSTEM 2 SUCTION PRESS (°F)
SAT_SUC_TMP3	SATURATED SUCTION TEMP CKT 3 (70-150 TON ONLY)	R	AI45	558	DISPLAYS THE SATURATION TEMP OF SYSTEM 3 SUCTION GAS BASED ON SYSTEM 3 SUCTION PRESS (°F)
SAT_TEMPER	SUPPLY AIR TEMPERING STATUS	R	BI53	1334	DISPLAYS THE STATUS OF SUPPLY AIR TEMPERING (ON/ OFF)

**TABLE 52 - BACnet MS/TP, MODBUS, BACnet IP (CONT'D)**

BACNET NAME	USER INTERFACE NAME	READ/ WRITE	BACNET/ OBJECT TYPE AND INSTANCE	MODBUS REGISTER ADDRESS	POINTS LIST DESCRIPTION
SEN/MSC_FLT	SENSOR/MISC FAULT STATUS	R	BI54	1335	DISPLAYS THE STATUS OF A SENSOR OR MISC FAULT (0=NO FAULT 1=FAULTED)
SF_PROV_SW	SUPPLY FAN STATUS	R	BI55	1336	DISPLAYS THE STATUS OF THE SUPPLY FAN AIR PROVING CIRCUIT (0=STOP VERIFICATION/CKT OPEN 1=RUN VERIFICATION/CKT CLOSED)
SF_SPD_H_SAT	FAN SPEED SP FOR HI SUPPLY AIR TEMP	R/W	AV29	1054	DISPLAYS THE SUPPLY FAN SPEED SP USED FOR SWITCHING TO THE HIGH SUPPLY AIR TEMP SP
SF_SPD_L_SAT	FAN SPEED SP FOR LO SUPPLY AIR TEMP	R/W	AV30	1055	DISPLAYS THE SUPPLY FAN SPEED SP USED FOR SWITCHING TO THE LOW SUPPLY AIR TEMP SP
SMOKE_PUR_1	SMOKE PURGE 1 STATUS	R	BI56	1337	DISPLAYS THE STATUS OF THE SMOKE PURGE 1 INPUT EITHER HARDWIRED OR COMMUNICATED (ON/OFF)
SMOKE_PUR_2	SMOKE PURGE 2 STATUS	R	BI57	1338	DISPLAYS THE STATUS OF THE SMOKE PURGE 2 INPUT EITHER HARDWIRED OR COMMUNICATED (ON/OFF)
SMOKE_PUR_3	SMOKE PURGE 3 STATUS	R	BI58	1339	DISPLAYS THE STATUS OF THE SMOKE PURGE 3 INPUT EITHER HARDWIRED OR COMMUNICATED (ON/OFF)
SMOKE_PUR1_B	SMOKE PURGE 1 BAS	R/W	AV90 BV14	1115	A BAS COMMAND THAT ALLOWS SMOKE PURGE 1 TO BE ACTIVATED (0=OFF 1=ON)
SMOKE_PUR2_B	SMOKE PURGE 2 BAS	R/W	AV91 BV15	1116	A BAS COMMAND THAT ALLOWS SMOKE PURGE 2 TO BE ACTIVATED (0=OFF 1=ON)
SMOKE_PUR3_B	SMOKE PURGE 3 BAS	R/W	AV92 BV16	1117	A BAS COMMAND THAT ALLOWS SMOKE PURGE 3 TO BE ACTIVATED (0=OFF 1=ON)
STG_1_COOL	1ST STAGE COOLING SP (CV/SZVAV)	R/W	AV31	1056	DISPLAYS THE ACTIVE SUPPLY AIR TEMP SP FOR A 1ST STAGE COOLING INPUT (Y1)
STG_1_HEAT	1ST STAGE HEATING SP (CV/ SZVAV)	R/W	AV32	1057	DISPLAYS THE ACTIVE SUPPLY AIR TEMP SP FOR A 1ST STAGE HEATING INPUT (W1)
STG_2_COOL	2ND STAGE COOLING SP (CV/SZVAV)	R/W	AV33	1058	DISPLAYS THE ACTIVE SUPPLY AIR TEMP SP FOR A 2ND STAGE COOLING INPUT (Y2)

**6**

**TABLE 52 - BACnet MS/TP, MODBUS, BACnet IP (CONT'D)**

BACNET NAME	USER INTERFACE NAME	READ/ WRITE	BACNET/ OBJECT TYPE AND INSTANCE	MODBUS REGISTER ADDRESS	POINTS LIST DESCRIPTION
STG_2_HEAT	2ND STAGE HEATING SP (CV/ SZVAV)	R/W	AV34	1059	DISPLAYS THE ACTIVE SUPPLY AIR TEMP SP FOR A 2ND STAGE HEATING INPUT (W2)
SUP_AIR_TEMP	SUPPLY AIR TEMP CURRENT	R	AI46	559	DISPLAYS THE ACTUAL SUPPLY AIR TEMP. (°F)
SUP_AIR_TRST	SUPPLY AIR TEMP RESET	R	AI47	560	DISPLAYS THE VALUE, 0-5 VDC, OF A HARDWIRED OR COMMUNICATED INPUT THAT WILL BE USED TO RESET THE SUPPLY AIR TEMP SP (VDC)
SUP_FAN_VFD	SUPPLY FAN VFD SPEED	R	AI48	561	DISPLAYS THE OUTPUT FROM THE CONTROL TO THE SUPPLY FAN VFD (%)
SUPPLY_FAN	SUPPLY FAN OUTPUT STATUS	R	BI59	1340	DISPLAYS THE STATUS OF THE OUTPUT FROM THE CONTROLLER TO THE SUPPLY FAN CIRCUIT (0=OFF 1=ON)
SYSTEM_STOP	SYSTEM STOP	R/W	AV35	1060	ALLOWS A BAS COMMAND THAT MANUALLY SHUTS DOWN COMPRESSOR CIRCUITS (0=ALL CKTS CAN OPERATE 1=SHUTS DOWN CKT 1 2=SHUTS DOWN CKT 2 3=SHUTS DOWN CKT 3)
SZ_MIN_VFD	SINGLE ZONE MINIMUM VFD	R/W	AV53	NA*	ALLOWS THE MINIMUM SUPPLY FAN SPEED TO BE RESET BETWEEN 33% AND 66% WHEN USING SZVAV.
TEMP_1_SUCT	SUCT TEMP CKT 1	R	AI49	562	DISPLAYS THE ACTUAL SYSTEM 1 SUCT LINE TEMP (°F)
TEMP_1_SUPER	SUCT SUPERHEAT CKT 1	R	AI50	563	DISPLAYS THE SYSTEM 1 SUPERHEAT (°F)
TEMP_2_SUCT	SUCT TEMP CKT 2	R	AI51	564	DISPLAYS THE ACTUAL SYSTEM 2 SUCT LINE TEMP (°F)
TEMP_2_SUPER	SUCT SUPERHEAT CKT 2	R	AI52	565	DISPLAYS THE SYSTEM 2 SUPERHEAT (°F)
TEMP_3_SUCT	SUCT TEMP CKT 3 (70-150 TON ONLY)	R	AI53	566	DISPLAYS THE ACTUAL SYSTEM 3 SUCT LINE TEMP (°F)
TEMP_3_SUPER	SUCT SUPERHEAT CKT 3 (70-150 TON ONLY)	R	AI54	567	DISPLAYS THE SYSTEM 3 SUPERHEAT (°F)

**TABLE 52 - BACnet MS/TP, MODBUS, BACnet IP (CONT'D)**

BACNET NAME	USER INTERFACE NAME	READ/ WRITE	BACNET/ OBJECT TYPE AND INSTANCE	MODBUS REGISTER ADDRESS	POINTS LIST DESCRIPTION
UND_FLR_DEWP	UNDERFLOOR SLAB DEW POINT (FLEXSYS)	R	A155	568	DISPLAYS THE CALCULATED DEW POINT OF THE UNDERFLOOR AIR (°F)
UND_FLR_HUMD	UNDERFLOOR AIR HUMIDITY (FLEXSYS)	R	A156	569	DISPLAYS THE HUMIDITY VALUE OF THE UNDERFLOOR AIR THAT THE UNIT IS CONTROLLED TO (°F)
UND_FLR_TEMP	UNDEFLOOR SLAB TEMP (FLEXSYS)	R	A157	570	DISPLAYS THE TEMP OF THE UNDERFLOOR AIR THAT THE UNIT IS CONTOLLING TO (°F)
UND_HUMD_BAS	UNDERFLOOR AIR HUMIDITY BAS	R/W	AV36	1061	ALLOWS THE BAS SYSTEM TO INPUT AN UNDERFLOOR AIR HUMIDITY VALUE TO THE CONTROL. (%) "UNDER FLR HUMI BAS" MUST BE ENABLED IN THE SERVICE MENU FOR THIS POINT TO FUNCTION
UND_TEMP_BAS	UNDERFLOOR SLAB TEMP BAS	R/W	AV37	1062	ALLOWS THE BAS SYSTEM TO INPUT AN UNDERFLOOR AIR TEMP VALUE TO THE CONTROL (°F) "UNDER FLR TEMP BAS" MUST BE ENABLED IN THE SERVICE MENU FOR THIS POINT TO FUNCTION
UNIT_MODE	CURRENT OPER MODE	R	A158	571	DISPLAYS THE CURRENT OPERATING MODE: 0=OCC COOL 1=OCC COOL LOW 2=OCC COOL HIGH 3=OCC COOL W/ BYP 4=OCC COOL W/O BYP 5= OCC HEAT 6=OCC HEAT LOW 7=OCC HEAT HIGH 8=OCC STANDBY 9=UNOCC COOL 10=UNOCC COOL LOW 11=UNOCC COOL HIGH 12=UNOCC HEAT 13=UNOCC HEAT LOW 14=UNOCC HEAT HIGH 15=UNOCC STANDBY 16=COMFORT VENT COOL 17=COMFORT VENT HEAT 18=NIGHT SET-BACK 19=MORNING WARM-UP 20=POWER UP STANDBY
UNIT_STOP	UNIT STOP	R/W	AV93 BV17	1118	A BAS COMMAND THAT ALLOWS THE UNIT TO BE SHUT DOWN (0=NORMAL OPERATION 1=UNIT STOPPED)

**TABLE 52 - BACnet MS/TP, MODBUS, BACnet IP (CONT'D)**

BACNET NAME	USER INTERFACE NAME	READ/ WRITE	BACNET/ OBJECT TYPE AND INSTANCE	MODBUS REGISTER ADDRESS	POINTS LIST DESCRIPTION
UNSTABLE_SYS	UNSTABLE SYSTEM STATUS (NOT USED)	R	BI60		
UNOCC_ZN_COOL	UNOCC ZONE COOLING SP	R/W	AV38	1063	UNOCC ZONE COOLING SP
UNOCC_ZN_HEAT	UNOCC ZONE HEATING SP	R/W	AV39	1064	UNOCC ZONE HEATING SP
VAV_HEAT	VAV HEAT RELAY STATUS	R	BI61	1342	DISPLAYS THE STATUS OF THE OUTPUT THAT ENERGIZES A VAV HEAT RELAY (OFF/ON)
VENT_CONTROL	VENTILATION CONTROL	R/W	AV94 BV18	1119	A BAS COMMAND THAT ALLOWS THE SELECTION OF THE VENTILATION FUNCTION (0=FIXED MINIMUM 1=DEMAND)
VENT_DEM_OUT	VENTILATION DEMAND	R	AI59	572	DISPLAYS THE STATUS OF THE VENTILATION OUTPUT FOR DEMAND VENTILATION (%)
VENT_ENABLE	VENTILATION SYSTEM	R/W	AV95 BV19	1120	A BAS COMMAND THAT ALLOWS THE VENTILATION FUNCTION TO BE TURNED ON OR OFF (0=OFF 1=ON)
W1_LO_HEAT_B	W1 LO HEAT BAS (CV ONLY)	R/W	AV96 BV20	1121	A BAS COMMAND THAT ALLOWS AN INPUT FOR W1, FIRST STAGE HEAT (0=OFF 1=ON)
W1_LOW_HEAT	W1 LOW HEAT STATUS	R	BI62	1343	DISPLAYS THE STATUS OF THE W1 HEAT INPUT EITHER HARDWIRED OR COMMUNICATED FROM A BAS (ON/OFF)
W2_HI_HEAT_B	W2 HIGH HEAT BAS (CV ONLY)	R/W	AV97 BV21	1122	A BAS COMMAND THAT ALLOWS AN INPUT FOR W2, SECOND STAGE HEAT (0=OFF 1=ON)
W2_HIGH_HEAT	W2 HIGH HEAT STATUS	R	BI63	1344	DISPLAYS THE STATUS OF THE W2 HEAT INPUT EITHER HARDWIRED OR COMMUNICATED FROM A BAS (ON/OFF)
Y1_LO_COOL_B	Y1 LO COOL BAS (CV ONLY)	R/W	AV98 BV22	1123	A BAS COMMAND THAT ALLOWS AN INPUT FOR Y1, FIRST STAGE COOL (0=OFF 1=ON)
Y1_LOW_COOL	Y1 LOW COOL STATUS	R	BI64	1345	DISPLAYS THE STATUS OF THE Y1 COOL INPUT EITHER HARDWIRED OR COMMUNICATED FROM A BAS (ON/OFF)



**TABLE 52 - BACnet MS/TP, MODBUS, BACnet IP (CONT'D)**

BACNET NAME	USER INTERFACE NAME	READ/ WRITE	BACNET/ OBJECT TYPE AND INSTANCE	MODBUS REGISTER ADDRESS	POINTS LIST DESCRIPTION
Y2_HI_COOL_B	Y2 HIGH COOL BAS (CV ONLY)	R/W	AV99 BV23	1124	A BAS COMMAND THAT ALLOWS AN INPUT FOR Y2, SECOND STAGE COOL (0=OFF 1=ON)
Y2_HIGH_COOL	Y2 HIGH COOL STATUS	R	BI65	1346	DISPLAYS THE STATUS OF THE Y2 COOL INPUT EITHER HARDWIRED OR COMMUNICATED FROM A BAS (ON/OFF)
ZONE_TEMP	ZONE TEMP CURRENT	R	AI60	573	DISPLAYS THE ACTUAL ZONE TEMPERATURE (°F)
ZONE_TEMP_BAS	ZONE TEMP BAS	R/W	AV40	1065	ALLOWS THE BAS SYSTEM TO INPUT AN ZONE TEMPERATURE READING (°F) THE CONTROL METHOD MUST BE SET TO "COMM ZONE TEMP" FOR THIS POINT TO FUNCTION

**NOTES**

- 1.The most up to date listing of the Standard Points Mapping can be found on the JCI website
- 2.For a Building Automation System using BACnet IP, a gateway must be used, since the unit controller does not have a BACnet IP port. We recommend using a JCI NCE (MS-NCE2560-0)

THIS PAGE INTENTIONALLY LEFT BLANK

## SECTION 7 – PARAMETER DESCRIPTIONS AND OPTIONS

**TABLE 53 - DEFINITIONS**

MENU ITEM	DEFINITION
<b>ACTIVE SLAB CONTROL</b>	This parameter is programmed through the Program key. This function allows heat to be turned on during the transition from Unoccupied to Occupied mode or Occupied to Unoccupied mode if the under floor conditions of a FlexSys system are right for the growth of mold and mildew. The choices are USER ENABLED or USER DISABLED.
<b>ADAPT MORN WARM UP</b>	This parameter is programmed through the Program key. Adaptive Morning Warm Up uses the past three days of warm up times and temperatures to calculate the start time for the current day. This parameter allows the user to USER ENABLED or USER DISABLED this feature.
<b>BLDG PRESSURE CNTRL OFFSET</b>	This parameter is programmed through the Setpoints key. The Unit Controller To determine when to turn on the exhaust fan. When the exhaust option is configured for “ON-OFF PRESS CNTRL.”
<b>BUILDING PRESSURE ACTIVE SETPOINT</b>	This parameter is programmed through the Setpoints key. It identifies the control point for the building pressure.
<b>BUILDING PRESSURE CURRENT</b>	This is the actual pressure in the conditioned space.
<b>BYPASS DAMPER POSITION</b>	This is the actual position of the bypass damper, by percent open, in a FlexSys unit.
<b>CO2 LEVEL INSIDE</b>	This is the CO2 level of the air in the conditioned space.
<b>CO2 LEVEL OUTSIDE</b>	This is the CO2 level of the outdoor air.
<b>CO2 OFFSET SETPOINT</b>	This parameter is programmed through the Setpoints key. The Outside CO2 level must be lower than the Indoor CO2 level plus the CO2 OFFSET SETPOINT before the outdoor door damper will start to open for additional ventilation.
<b>CO2 OFFSET CURRENT</b>	This represents the current difference between the “CO2 LEVEL INSIDE” versus the “CO2 LEVEL OUTSIDE.”
<b>COMFORT VENTILATION</b>	This parameter is programmed through the Program key. This function is only used on a Constant Volume or SZVAV unit. The Unit Controller monitors the Zone Temperature and energizes stages of cooling or heating prior to a demand from the space. This function is only active when the unit is in the Occupied mode. The choices are USER ENABLED or USER DISABLED.
<b>COMP SYS 1 STATUS</b>	This is the current operating mode of the system 1 compressors. The display will show Normal - Comp A On, Normal - Comp B On, Normal - Both ON, Normal - Both Off, Safety Trip, Safety Fault, Safety Lockout, Low Amb Inhibit, Low Suct Temp Unl, High DP Unload, or User Disabled.
<b>COMP SYS 2 STATUS</b>	This is the current operating mode of the system 2 compressors. The display will show Normal - Comp A On, Normal - Comp B On, Normal - Both ON, Normal - Both Off, Safety Trip, Safety Fault, Safety Lockout, Low Amb Inhibit, Low Suct Temp Unl, High DP Unload, or User Disabled.
<b>CONDENSER FAN 1A/1</b>	This identifies if the Unit Controller has sent a Binary output to Condenser Fan 1A /1.
<b>CONDENSER FAN 1B/2</b>	This identifies if the Unit Controller has sent a Binary output to Condenser Fan 1B /2.
<b>CONDENSER FAN 2A/3</b>	This identifies if the Unit Controller has sent a Binary output to Condenser Fan 2A /3.
<b>CONDENSER FAN 2B/4</b>	This identifies if the Unit Controller has sent a Binary output to Condenser Fan 2B/4.
<b>CONTINUOUS VENT</b>	This parameter is programmed through the Program key. This is only used on a Constant Volume or SZVAV unit. When this parameter is enabled the supply blower will operate whenever the unit is in the Occupied mode. The choices are USER ENABLED or USER DISABLED.
<b>CONTROL METHOD</b>	This parameter is programmed through the Options key and identifies the control method being used on a Constant Volume or SZVAV unit. The choices are Staged, Wired Zone Temp or Comm Zone Temp.
<b>COOLING CONTROL OFFSET</b>	This is the control band the unit is trying to maintain. The control band is the Active Setpoint +/- the Cooling Control Offset. If the temperature is above this band additional cooling is required, if the temperature is below this band cooling is decreased.

**TABLE 53 - DEFINITIONS (CONT'D)**

<b>MENU ITEM</b>	<b>DEFINITION</b>
<b>CURRENT OPER MODE</b>	This is the current operating mode of the unit. The display will show Occ Standby, Occ Cooling Low, Occ Cooling High, Occ Heating Low, Occ Heating High, Unocc Standby, Unocc Cooling Low, Unocc Cooling High, Unocc Heating Low, Unocc Heating High, Morning Warm-up, Comfort Vent Cooling, Comfort Vent Heating, Occupied Cooling, Occupied Heating, Unoccupied Cooling, Unoccupied Heating, Occ Cooling W/O Bypass, Occ Cooling W Bypass, or Underfloor Temp Override.
<b>CURRENT RUN TIME COMP A</b>	This is the amount of time the compressor has been in operation during the current cycle. This is shown for each compressor of every compressor system.
<b>CURRENT RUN TIME COMP B</b>	This is the amount of time the compressor has been in operation during the current cycle. This is shown for each compressor of every compressor system.
<b>DAILY WARM UP TIME</b>	This is the time it takes to bring the Return Air Temperature up to setpoint during Adaptive Morning Warm Up. The Unit Controller uses this value in the calculation of Daily Warm Up Time Day 1.
<b>DAILY WARM UP TIME DAY 1</b>	This is the Morning Warm Up time the Unit Controller recorded during the previous day 1. This value is used to calculate the current Morning Warm initiate time for Adaptive Morning Warm Up.
<b>DAILY WARM UP TIME DAY 2</b>	This is the Morning Warm Up time the Unit Controller recorded during the previous day 2. This value is used to calculate the current Morning Warm initiate time for Adaptive Morning Warm Up.
<b>DAILY WARM UP TIME DAY 3</b>	This is the Morning Warm Up time the Unit Controller recorded during the previous day 3. This value is used to calculate the current Morning Warm initiate time for Adaptive Morning Warm Up.
<b>DAMPER HARDWARE</b>	This parameter is programmed through the Options key and identifies the type of ventilation system installed in the unit. The choices are None, 2 Position Damper, Standard Dampers, Minimum IAQ, Full IAQ, TEK-Air Full IAQ, 1/3-2/3 IAQ.*
<b>DEW POINT RESET</b>	This parameter is programmed through the Program key. This function changes the Active Supply Air Temperature to a lower value when the air beneath the floor of a FlexSys unit approaches the dew point temperature of the air. The choices are USER ENABLED or USER DISABLED.
<b>DISPLAY LANGUAGE</b>	This parameter is programmed through the Options key. This allows the user to select the language the Unit Controller will use to display the information at the User Interface. The choices are English or Spanish.
<b>DISPLAY UNITS</b>	This parameter is programmed through the Options key. This allows the user to select which unit of measure the Unit Controller will use to display the information at the User Interface. The choices are Imperial, metric.
<b>DUCT PRESS TRANSDUCER SPAN</b>	This parameter is programmed through the Setpoints key. This allows the use of three different duct pressure control ranges, 0 to 1.00 in-wg, 0 to 2.50 in-wg, or 0 to 5.00 in-wg.
<b>DUCT STATIC OVER PRESSURE</b>	This parameter is programmed through the Setpoints key. This sets the maximum allowable Duct Static value before the Unit Controller lockouts the unit on an over pressure fault.
<b>DUCT STATIC PRESS ACTIVE SP</b>	This is the current Duct Static Setpoint that the Unit Controller is trying to maintain.
<b>DUCT STATIC PRESS CURRENT</b>	This is the actual duct static pressure value.
<b>DUCT STATIC RESET LOW SETP</b>	This parameter is programmed through the Setpoints key. This is the minimum Duct Static Control point.
<b>DUCT STATIC RESET HIGH SETP</b>	This parameter is programmed through the Setpoints key. This is the maximum Duct Static Control point.
<b>ECONOMIZER CONTROL OUTPUT</b>	This is the analog output from the Unit Controller to the Economizer Damper Actuator.

\*Note: Minimum IAQ, Full IAQ, and 1/3-2/3 IAQ are not used on the Series 100, 50–65 Ton, Rev F units.

**TABLE 53 - DEFINITIONS (CONT'D)**

MENU ITEM	DEFINITION
<b>ECONO INSTALLED</b>	This parameter is programmed through the Program key and tells the Unit Controller what type of economizer is installed, None, Dry Bulb, Single Enthalpy, Dual Enthalpy.
<b>ECONO METHOD ACTIVE</b>	This value indicates which of the available economizer methods the Unit Controller is using.
<b>ECONO METHOD TO USE</b>	This parameter is programmed through the Program key and tells the Unit Controller which of the available economizer options to use. The choices are Dry Bulb, Single Enthalpy, Dual Enthalpy, or Best Available.
<b>ECONO OUTPUT FOR FAN START</b>	This parameter is set through the Setpoints key and identifies the position of the economizer damper required to turn ON the exhaust fan in an ON/OFF DAMPER CTRL.
<b>ECONO OUTPUT FOR FAN STOP</b>	This parameter is set through the Setpoints key and identifies the position of the economizer damper required to turn OFF the exhaust fan in an ON/OFF DAMPER CTRL option.
<b>ECONO SYS STATUS</b>	This is the active status of the economizer system, display will show Normal- Active, Normal-Inactive, Faulted, User Disabled; or None.
<b>ELEC HEAT CAPACITY</b>	This parameter is programmed through the Options key. This parameter is used to identify the electric heat capacity installed in the unit. The options are 40 KW, 80 KW, 40 KW-200, 80 KW-200, 100 KW, 100 KW-200, 108 KW, 120 KW, 150 KW, 160 KW, 200 KW, 240 KW, or 250 KW.
<b>EVAP LEAVING AIR TEMP HIGH</b>	This parameter is programmed through the Setpoints key. This becomes the Active Supply Air Temperature Setpoint for a FlexSys unit when it is in the Occupied Cooling With Bypass mode.
<b>EVAP LEAVING AIR TEMP LOW</b>	This parameter is programmed through the Setpoints key. This becomes the Active Supply Air Temperature Setpoint for a FlexSys unit when it is in the Dew Point Reset mode.
<b>EXHAUST DAMPER POSITION/VFD</b>	This identifies the percentage output from the Unit Controller to the Exhaust Damper or Exhaust Fan when controlled by the unit or BAS (when exhaust Control BAS is enabled).
<b>EXHAUST FAN OUTPUT</b>	This identifies the Unit Controller is sending a Binary output to energize the exhaust fan circuit.
<b>EXHAUST FAN STATUS</b>	This verifies a Binary input to the Unit Controller is present when the exhaust fan is operating.
<b>EXHAUST OUTPUT FOR FAN START</b>	This parameter is set through the Setpoints key and identifies the position of the exhaust damper required to turn ON the exhaust fan in an ON/OFF PRESS CNTRL option.
<b>EXHAUST OUTPUT FOR FAN STOP</b>	This parameter is set through the Setpoints key and identifies the position of the exhaust damper required to turn OFF the exhaust fan in an ON/OFF PRESS CNTRL option.
<b>EXHAUST/RETURN FAN VFD</b>	This is a derived value that indicates the output, in percent, to the Return Fan VFD.
<b>EXHAUST SYS STATUS</b>	This is the active status of the exhaust system. The display will show Normal-Active, Normal-Inactive, Faulted, User Disabled, or None.
<b>EXHAUST/RETURN FAN VFD</b>	This identifies speed output in percentage that is being sent to the exhaust or return fan VFD.
<b>FAN SPEED SETP FOR HIGH SAT</b>	This parameter is programmed through the Setpoints key. When the supply fan speed is equal to or less than this value the Active Supply Air Temperature Setpoint on a Variable Air Volume Unit will be set to the SAT Setpoint High Limit.
<b>FAN SPEED SETP FOR LOW SAT</b>	This parameter is programmed through the Setpoints key. When the supply fan speed is equal to or greater than this value the Active Supply Air Temperature Setpoint on a Variable Air Volume Unit will be set to the SAT Setpoint Low Limit.
<b>FILTER STATUS</b>	This is status of the unit filters. A differential pressure switch must be installed to measure the pressure drop across the filters. When the filters are dirty the switch closes sending a Binary signal to the Unit Controller. The User Interface display will show Okay or Change.
<b>FLEX EVAP TEMP ACTIVE SP</b>	This is the active evaporator temperature setpoint that the Unit Controller is trying to control to. This value is used when a FlexSys unit is in the Occupied Cooling With Bypass mode.
<b>FLEX EVAP TEMP CURRENT</b>	This is the actual air temperature leaving the evaporator coil of a FlexSys unit.
<b>FURNACE 1 MODE</b>	This is the current status of the first heat exchanger section of a staged gas heat unit. The User Interface will display Off, Purge, Ignition, On-Low, On-High, Safety Trip, Safety Fault, Safety Lockout, or Fault- I/O.

**TABLE 53 - DEFINITIONS (CONT'D)**

MENU ITEM	DEFINITION
<b>FURNACE 1A MODE</b>	This is the current status of the modulating section of the modulating gas heat furnace. The User Interface will display Off, Purge, Ignition, On-Low, On-High, Safety Trip, Safety Fault, Safety Lockout, or Fault- I/O.
<b>FURNACE 1B MODE</b>	This is the current status of the non-modulating section of the modulating gas heat furnace. The User Interface will display Off, Purge, Ignition, On, Safety Trip, Safety Fault, Safety Lockout, or Fault- I/O.
<b>FURNACE 2 MODE</b>	This is the current status of the second heat exchanger section of a staged gas heat unit. The User Interface will display Off, Purge, Ignition, On-Low, On-High, Safety Trip, Safety Fault, Safety Lockout, or Fault- I/O.
<b>FURNACE 3 MODE</b>	This is the current status of the third heat exchanger section of a staged gas heat unit. The User Interface will display Off, Purge, Ignition, On-Low, On-High, Safety Trip, Safety Fault, Safety Lockout, or Fault- I/O.
<b>GAS HEAT CAPACITY</b>	This parameter is programmed through the Options key. This parameter is used to identify the gas heat capacity installed in the unit. The options are 375 MBH, 750 MBH, or 1125 MBH.
<b>HEAT ENTERING TEMP</b>	This is the temperature of the supply air entering the staged heat section. This value is used to initiate and terminate Supply Air Tempering when Staged Heat is installed.
<b>HEAT LIMIT TEMPERATURE</b>	This parameter is programmed through the Setpoints key. This value determines the maximum allowable Supply Air Temperature when heating is installed. If the temperature goes above this setting the heat section will be shut down.
<b>HEATING CONTROL OFFSET</b>	This is the control band the unit is trying to maintain. The control band is the Active Setpoint +/- the Heating Control Offset. If the temperature is below this band, additional heating is required, if the temperature is above this band heating is decreased.
<b>HEATING SAT</b>	This parameter is programmed through the Setpoints key. On a VAV or FlexSys unit this becomes the Active Supply Air Temperature Setpoint for heating operation. The Unit Controller controls the heating option to try and maintain this temperature.
<b>HEATING SYS STATUS</b>	This is the current operating mode of the Heating Section. The display will show Normal - Active, Normal - Inactive, Safety Trip, Safety Fault, Safety Lockout, User Disabled, or None.
<b>HEATING SYSTEM TYPE</b>	This parameter is programmed through the Options key. This parameter is used to identify the type of heat installed in the unit. The options are None, Electric, Stage Gas, Modulating Gas, Hot Water / Steam.
<b>HW / STEAM FRZ STAT</b>	This is the status of the hydronic heat freezestat. This is done through a Binary input to the Unit Controller. The switch is closed for normal operation and opens on failure. The User Interface will indicate OK or FAULTED.
<b>HW / STEAM HEAT - VALVE POS</b>	This is the output from the Unit Controller to the hydronic valve as percent open.
<b>HW VALVE ACTION</b>	This parameter is programmed through the Program key. This parameter controls the output to the hydronic modulating valve. When the parameter is set to DIRECT the output is 0 volts for off and 10 volts for full capacity. When the parameter is set to REVERSE the output is 10 volts for off and 0 volts for full capacity.
<b>IAQ DMPR AIR FLOWS OA FLOW 1</b>	This is the airflow through a Tek Air Full IAQ.
<b>MAXIMUM BYPASS</b>	This parameter is programmed through the Setpoints key. It establishes the maximum allowable position of the bypass damper in a FlexSys unit.
<b>MECH CLG LOCKOUT TEMP</b>	This parameter is programmed through the Setpoints key. When the outdoor temperature is equal to or less than this temperature, the Unit Controller will prevent the compressors from operating.
<b>MINIMUM OA FLOW SETPOINT</b>	This parameter is programmed through the Setpoints key. When air measurement stations are installed and the unit is not in the Occupied mode, this is the minimum allowable airflow.

**TABLE 53 - DEFINITIONS (CONT'D)**

MENU ITEM	DEFINITION
<b>MX SUPPLY AIR TEMP</b>	This parameter is programmed through the Setpoints key. This becomes the Active Supply Air Temperature Setpoint for a FlexSys unit when it is in the Occupied Cooling Without Bypass mode.
<b>FURNACE 1A MODE APRX RATE</b>	This is the approximate firing rate of the modulating gas heat section in MBH.
<b>FURNACE 1A MODE RELATIVE</b>	This is the output from the Unit Controller to the modulating gas heat section in percent of full capacity.
<b>MORNING WARM UP</b>	This parameter is programmed through the Program key. This tells the Unit Controller if the Morning Warmup option is available or not. When it is programmed to USER ENABLED, Morning Warm Up is available to be used. When it is programmed to USER DISABLED, Morning Warm Up is unavailable.
<b>MORNING WARM UP MAX TIME</b>	This parameter is programmed through the Setpoints key. This value is the maximum time the Unit Controller will allow for Morning Warm Up when the unit is in the Adaptive Morning Warm Up mode. If the derived Morning Warm Up Opt Time exceed this time the Morning Warm Up Max Time will be used.
<b>MORNING WARM UP OPT TIME</b>	This is the average of the previous three days Warm Up times plus 10 minutes. This value will be used to determine the Morning Warm Up start time for the next day when the unit is in the Adaptive Morning Warm Up mode.
<b>NIGHT SET BACK</b>	This parameter is programmed through the Program key. This parameter allows the user to enable or disable Night Set Back. If this parameter is disabled Unoccupied Heating will not be available. The two parameters to choose from are USER ENABLED or USER DISABLED.
<b>OA DAMPER MAXIMUM POSITION</b>	This parameter is programmed through the Setpoints key. This establishes the maximum amount of ventilation air to be used in a Demand Ventilation situation.
<b>OA DAMPER MINIMUM POSITION</b>	This parameter is programmed through the Setpoints key. This establishes the minimum amount of ventilation air to be used when the unit is in the Occupied mode.
<b>OA DAMPER POSITION ACTIVE SP</b>	This is the damper position setpoint, in percent open, the Unit Controller is trying to maintain.
<b>OA DAMPER POSITION CURRENT</b>	This is the actual output, in percent open to the outdoor air damper.
<b>OUTSIDE AIR ENTHALPY</b>	This indicates the total heat content of the outdoor air.
<b>OUTSIDE AIR HUMIDITY</b>	This is the outdoor air relative humidity.
<b>OUTSIDE AIR TEMP</b>	This is the outdoor air dry bulb temperature.
<b>OAT SETPOINT FOR HIGH SAT</b>	This parameter is programmed through the Setpoints key. When the outdoor temperature is equal to or less than this temperature the Active Supply Air Temperature Setpoint on a Variable Air Volume Unit will be set to the SAT HIGH SETPOINT.
<b>OAT SETPOINT FOR LOW SAT</b>	This parameter is programmed through the Setpoints key. When the outdoor temperature is equal to or greater than this temperature the Active Supply Air Temperature Setpoint on a Variable Air Volume Unit will be set to the SAT LOW SETPOINT.
<b>OUTSIDE AIR ENTHALPY SETPOINT</b>	This parameter is programmed through the Setpoints key and is the upper limit of outdoor enthalpy that can be used for economizer operation. If the outdoor air enthalpy is above this value, the economizer is made inactive.
<b>OUTSIDE AIR FLOW ACTIVE SP</b>	This is the airflow setpoint that the Unit Controller is trying to maintain.
<b>OUTSIDE AIR FLOW TOTAL</b>	This is the same as OA Flow 1 for Tek Air Full IAQ
<b>OUTSIDE AIR MAXIMUM FLOW</b>	This parameter is programmed through the Setpoints key. When air measurement stations are installed and the unit is in the Demand Ventilation mode, this is the maximum allowable airflow value.
<b>OUTSIDE AIR MINIMUM FLOW</b>	This parameter is programmed through the Setpoints key. When air measurement stations are installed and the unit is in the Demand Ventilation mode, this is the minimum airflow value.

**TABLE 53 - DEFINITIONS (CONT'D)**

<b>MENU ITEM</b>	<b>DEFINITION</b>
<b>POWER EXHAUST TYPE</b>	This parameter is programmed through the Options key and tells the Unit Controller what type of Exhaust is installed. The choices are None, On-Off Damper Cntrl, On-Off Press Cntrl, Modulate Damper VFD, Return Fan W/Exh, or Return Fan W/O Exh.
<b>PRESS TRANS PKG</b>	This parameter is programmed through the Options key. This identifies to the Unit Controller which of the compressor systems are configured with suction and discharge pressure transducers. The options are None, Sys 1 or Sys 1, 2.
<b>PRESSURE DISCHARGE**</b>	This is the discharge pressure and is shown for each compressor system if pressure transducers are installed and configured for the system.
<b>PRESSURE SUCTION**</b>	This is the suction pressure and is shown for each compressor system if pressure transducers are installed and configured for the system.
<b>PUMPDOWN</b>	This parameter is programmed through the Program key. If Pumpdown is USER ENABLED at the end of the compressor system cycle the solenoid valve to the expansion valves will close and the compressor will continue to operate for 30 seconds or until the low pressure cutout opens. This removes the refrigerant from the low side of the system. The choices are USER ENABLED or USER DISABLED. If Pumpdown is ENABLED all compressor system will use Pumpdown.
<b>RETURN AIR ENTHALPY</b>	This is the total heat content of the return air.
<b>RETURN AIR HUMIDITY</b>	This is the return air relative humidity.
<b>RETURN AIR TEMP</b>	This is the return air dry bulb temperature.
<b>RETURN AIR TEMP CURRENT</b>	This is the temperature of the return air entering the unit.
<b>RAT HEATING SETPOINT</b>	On a VAV or FlexSys unit, the Unit Controller monitors the RAT HEATING SETPOINT. When the return air temperature is 0.5 °F below this value the control switches into the Occupied Heating mode.
<b>RAT COOLING SETPOINT</b>	On a VAV or FlexSys unit, the Unit Controller monitors the RAT COOLING SETPOINT. When the return air temperature is 0.5 °F above this value the control switches into the Occupied Cooling mode.
<b>RAT SETPOINT FOR HIGH SAT</b>	This parameter is programmed through the Setpoints key. When the Return Air Temperature is equal to or LESS than this temperature the Active Supply Air Temperature Setpoint on a Variable Air Volume Unit will be set to the SAT HIGH SETPOINT.
<b>RAT SETPOINT FOR LOW SAT</b>	This parameter is programmed through the Setpoints key. When the Return Air Temperature is equal to or greater than this temperature the Active Supply Air Temperature Setpoint on a Variable Air Volume Unit will be set to the SAT LOW SETPOINT.
<b>READY TO RUN COMP A</b>	This means the minimum OFF time has been achieved and all the safety circuits are closed and compressor A of the system is ready to be energized. The User Interface will display either YES or NO.
<b>READY TO RUN COMP B</b>	This means the minimum OFF time has been achieved and all the safety circuits are closed and compressor B of the system is ready to be energized. The User Interface will display either YES or NO.
<b>READY TO STOP COMP A</b>	This means the minimum ON time has been achieved and compressor A of the system is ready to be de-energized. The User Interface will display either YES or NO.
<b>READY TO STOP COMP B</b>	This means the minimum ON time has been achieved and compressor B of the system is ready to be de-energized. The User Interface will display either YES or NO.
<b>REFRIGERANT TYPE</b>	This parameter is programmed through the Options key and identifies the type of refrigerant in the unit. The choices are R22, R407C, or R-410a.
<b>RETURN AIR BYPASS ACTIVE SP</b>	This is the position of the bypass damper by percent open the Unit Controller uses as the bypass setpoint on a FlexSys unit.
<b>RETURN AIR BYPASS CURRENT</b>	This is the position of the by-pass damper by percent open the Unit Controller uses as the Active Bypass percent setpoint on a FlexSys unit.

\*\* May be 1 or 2



**TABLE 53 - DEFINITIONS (CONT'D)**

MENU ITEM	DEFINITION
<b>RETURN FAN PRESSURE ACTIVE SP</b> <b>RETURN FAN PRESS CURRENT</b>	This is the current mixed air chamber pressure that the Unit Controller is trying to maintain.  This is the actual pressure in the mixed air chamber of the unit.
<b>RETURN FAN OUTPUT</b>	This is the Binary output from the Unit Controller to the Return Fan control system.
<b>RETURN FAN STATUS</b>	This is a Binary input into the Unit Controller that identifies the Return Fan is functioning.
<b>SAFETY INPUT LPCO</b>	This is the Binary input to the Unit Controller from the Low Pressure Cutout safety circuit. ON means the safety circuit is normal and FAULTED means it has faulted. This parameter will be shown for each compressor system.
<b>SAFETY INPUT CHAIN</b>	This is the Binary input to the Unit Controller from the Compressor Safety Circuit Chain. This includes the high pressure cutout and compressor motor protector. ON means the safety circuit is normal and FAULTED means it has faulted. This parameter will be shown for each compressor system.
<b>SAT RESET METHOD</b>	This parameter is programmed through the Options key and identifies the Supply Air Temperature reset method being used on a Variable Air Volume Unit. The choices are Hardwired, Outside Air, Return Air, or Supply Fan Speed.
<b>SAT HIGH SETPOINT</b>	This parameter is programmed through the Setpoints key. This establishes the maximum Active Supply Air Temperature to be used in a Variable Air Volume Unit.
<b>SAT LOW SETPOINT</b>	This parameter is programmed through the Setpoints key. This establishes the minimum Active Supply Air Temperature to be used in a Variable Air Volume Unit.
<b>SENSOR / MISC STATUS</b>	This is the current status of the Sensors. The display will show Normal, Warning, Safety Trip, Safety Fault, or Safety Lockout.
<b>SINGLE ZONE MINIMUM VAV SPEED</b>	This parameter provides the minimum speed of the Supply Fan during SZVAV operation.
<b>SMOKE PURGE SEQ 1</b>	This parameter is programmed through the Options key. This allows the user to select which of the three smoke purge sequences to use a sequence 1, Purge, Pressurization, or Evacuation. Smoke Purge Sequence 1 is energized through a Binary input to the Unit Controller.
<b>SMOKE PURGE SEQ 2</b>	This parameter is programmed through the Options key. This allows the user to select which of the three smoke purge sequences to use a sequence 2, Purge, Pressurization, or Evacuation. Smoke Purge Sequence 2 is energized through a Binary input to the Unit Controller.
<b>SMOKE PURGE SEQ 3</b>	This parameter is programmed through the Options key. This allows the user to select which of the three smoke purge sequences to use a sequence 3, Purge, Pressurization, or Evacuation. Smoke Purge Sequence 3 is energized through a Binary input to the Unit Controller.
<b>1ST STAGE COOLING SETPOINT</b>	This parameter is programmed through the Setpoints key. This value is used in a Constant Volume unit as the Active SAT Setpoint for 1st Stage cooling operation.
<b>1ST STAGE HEATING SETPOINT</b>	This parameter is programmed through the Setpoints key. This value is used in a Constant Volume unit as the Active SAT Setpoint for 1st Stage heating operation.
<b>2ND STAGE 2 COOLING SETPOINT</b>	This parameter is programmed through the Setpoints key. This value is used in a Constant Volume unit as the Active SAT Setpoint for 2nd Stage cooling operation.
<b>2ND STAGE 2 HEATING SETPOINT</b>	This parameter is programmed through the Setpoints key. This value is used in a Constant Volume unit as the Active SAT Setpoint for 2nd Stage heating operation.
<b>STAGED HEAT STATUS STGS ON</b>	This identifies the number of stages of gas or electric heat that the Unit Controller has energized.
<b>STAGED HEAT STATUS STGS AVAIL</b>	This identifies the number of stages of gas or electric heat that are available.
<b>SUCTION TEMP</b>	This is the temperature of the suction line leaving the evaporator coil and will be shown for each system. This value is monitored and used to prevent liquid refrigerant from being returned to the compressor.

**TABLE 53 - DEFINITIONS (CONT'D)**

<b>MENU ITEM</b>	<b>DEFINITION</b>
<b>SUP AIR TEMPERING</b>	This parameter is programmed through the Program key. This parameter is used to allow the heat to operate when the unit is in the Occupied Standby mode to temper the ventilation air entering the space. The choices are USER ENABLED or USER DISABLED.
<b>SUPPLY AIR TEMP ACTIVE SP</b>	This is the Supply Air Temperature the Unit Controller is trying to maintain.
<b>SUPPLY AIR TEMP CURRENT</b>	This is the current Supply Air Temperature supplied by the unit.
<b>SUPPLY FAN OUTPUT</b>	This is the Binary output from the Unit Controller to the Supply Fan control system.
<b>SUPPLY FAN OUTPUT PROOF</b>	This is a Binary input into the Unit Controller that identifies the Supply Fan is functioning.
<b>SUPPLY FAN VFD SPEED</b>	This indicates the output, in percent, to the Supply Fan VFD.
<b>SUPPLY SYS STATUS</b>	This is the active status of the Supply System, display will show Normal- Active; Normal-Inactive; Safety Trip, Safety Fault, or Safety Lockout.
<b>SYSTEM UNLOADING PRESSURE</b>	This parameter is programmed through the Setpoints key. If two compressors of the system are operative and the discharge pressure is equal to or greater than this value the Unit Controller will turn off one of the compressors. This feature is only operative when a discharge pressure transducer is installed in the compressor system.
<b>TEMPERATURE SUPERHEAT</b>	This is calculated for each compressor system that has a suction line pressure transducer installed and configured. This is the refrigerant evaporator superheat leaving the evaporator coil.
<b>UNDERFLOOR AIR HUMIDITY</b>	This is the humidity level under the floor of a FlexSys installation.
<b>UNDERFLOOR AIR TEMP</b>	This is the temperature of the air in the underfloor space.
<b>UNDERFLOOR SLAB DEW POINT</b>	This is the dewpoint of the air beneath the floor of a FlexSys installation.
<b>UNDERFLOOR SLAB TEMP</b>	This is the temperature of the slab beneath the floor of a FlexSys installation.
<b>UNIT INSTALLED ALTITUDE</b>	This parameter is programmed through the Setpoints key. This is the altitude at which the unit is installed. This is used in the calculation of an airflow correction factory when air measuring stations are installed.
<b>UNIT SIZE</b>	This parameter is programmed through the Options key and identifies the size of the unit. The choices are 50 Ton, 51 Ton, 60 Ton or 61 Ton.
<b>UNIT TYPE</b>	This parameter is programmed through the Options key and identifies the type of unit. The choices are Constant Volume, Variable Volume, or FlexSys.
<b>UNIT-OVERALL STATUS</b>	This is the active status of the Unit. The display will show Local Stop, Run, Unit Trip, Unit Fault, Unit Lockout, SMK Purge # - Press, SMK Purge #-Purge, or Smk Purge #-Evac.
<b>VENT SYS STATUS</b>	This is the active status of the Ventilation System. The display will show Normal- Active, Normal-Inactive, Safety Trip, Safety Fault, Safety Lockout, User Disabled, or None.
<b>VENTILATION CONTROL</b>	This parameter is programmed through the Options key and identifies whether the unit will operate with a Fixed Minimum or Demand ventilation system.
<b>VENTILATION DEMAND</b>	This is the output in percent to the outside air damper when the unit is operating in the Demand Ventilation mode.

**TABLE 53 - DEFINITIONS (CONT'D)**

<b>MENU ITEM</b>	<b>DEFINITION</b>
<b>ZONE TEMP OCC ZONE COOLING SETPOINT</b>	This parameter is programmed using the Setpoints key. This is the temperature that the Unit Controller compares the actual space temperature to, to decide when to switch into the Occupied Cooling Mode.
<b>ZONE TEMP OCC ZONE HEATING SETPOINT</b>	This parameter is programmed using the Setpoints key. This is the temperature that the Unit Controller compares the actual space temperature to decide when to switch into the Occupied Heating Mode.
<b>ZONE TEMP UNOCC ZONE COOLING SETPOINT</b>	This parameter is programmed using the Setpoints key. This is the temperature that the Unit Controller compares the actual space temperature to decide when to switch into the Unoccupied Cooling Mode.
<b>ZONE TEMP UNOCC ZONE HEATING SETPOINT</b>	This parameter is programmed using the Setpoints key. This is the temperature that the Unit Controller compares the actual space temperature to decide when to switch into the Unoccupied Heating Mode.
<b>ZONE TEMP CURRENT</b>	This is the temperature in the conditioned space.

THIS PAGE INTENTIONALLY LEFT BLANK

## SECTION 8 – SERVICE

### ANALOG INPUT OPERATION

This section describes the control operation of the 29 analog inputs. These inputs are used by the control to monitor and respond to unit temperatures, pressures, enthalpy, etc. The location of each of these connections on the Unit Controller is contained in *Table 63 on page 190*. Notice that the ID gives the jack connection designated as “J” and then the identifying number of the connector, followed by a “-” and then the pin number of the connector. For example, the SUPPLY AIR TEMPERATURE analog input would be found at J1-1. This is connector J1 – Pin 1. As the Unit Control board is positioned in the control box, the top row of the J series connectors is the input, the middle row is the common, and the bottom row is the 5 VDC input to the sensor. Also, the pin in the right-hand, top corner is pin 1.

### Temperature Sensors

The temperature sensors are all 10K Type III Thermistors. The relationship between the temperature and the voltage output and resistance is contained in *Table 54 on page 181*. The following analog inputs are of this type: Supply Air Temperature, Heat Entering Temp, Flex Evap Temp, Outside Air Temp, Return Air Temp, Suction Temp #1, Suction Temp #2, Zone Temp, and Under Floor Temp.

**TABLE 54 - TEMPERATURE SENSOR RESISTANCE**

°F	VOLTAGE	RESISTANCE	°C
-25	0.49	139,639	-30.6
-20	0.53	127,453	-28.9
-15	0.60	109,624	-26.1
-10	0.69	94,519	-23.34
-5	0.78	81,665	-20.55
0.0	0.88	70,750	-17.78
5	0.98	61,418	-15.00
10	1.10	53,426	-12.22
15	1.22	46,582	-9.44
20	1.35	40,703	-6.67
25	1.48	35,639	-3.89
30	1.62	31,269	-1.11
35	1.77	27,490	1.67
40	1.91	24,219	4.44
45	2.06	21,377	7.22
50	2.21	18,900	10.00
55	2.36	16,744	12.78

### Duct Pressure Transducer

The Duct Pressure Transducer is located behind the right hand damper door. The purpose of the transducer is to sense and convert the static pressure in the supply-side of the duct to a 0 to 5 VDC voltage. The DC voltage is sent to the Unit Controller and compared against the “*DUCT STATIC PRESS ACTIVE SP.*” The transducer is factory wired, but pneumatic tubing must be field supplied and installed (*refer to SECTION 2 – INSTALLATION*). The duct static pressure transducer measures differential pressure between the pressure in the duct and atmospheric pressure. When verifying transducer operation, the technician must insert a tee in the pneumatic tubing and connect a manometer to the tee to verify the pressure being applied to the transducer. Once this pressure is known, a comparison can be made of the duct pressure vs. output VDC from the transducer. *Table 56 on page 182* shows the relationship between the pressure applied to the duct pressure transducer and the output voltage. The output is linear between 0.0 "W.C. and the SPAN. The “*DUCT PRESS TRANSDUCER SPAN*” can be set to 1.25, 2.5, or 5.0 "W.C.

The “*DUCT PRESS TRANSDUCER SPAN*” must always be set based on the span of the transducer installed.

°F	VOLTAGE	RESISTANCE	°C
60	2.51	14,681	15.56
65	2.66	13,216	18.33
70	2.80	11,771	21.11
75	2.94	10,502	23.89
80	3.08	9,388	26.67
85	3.21	8,404	29.45
90	3.33	7,537	32.22
95	3.45	6,770	35.0
100	3.56	6,090	37.78
105	3.66	5,487	40.56
110	3.76	4,951	43.34
115	3.85	4,475	46.11
120	3.94	4,050	48.89
125	4.02	3,671	51.66
130	4.09	3,332	54.44
135	4.16	3,029	57.22

**TABLE 55 - DUCT PRESSURE TRANSDUCER**

1.25 "W.C. SPAN DIFFERENTIAL INPUT PRESS	2.5 "W.C. SPAN DIFFERENTIAL INPUT PRESS	5.0 "W.C. SPAN DIFFERENTIAL INPUT PRESS	VOLTAGE VDC
0.125	0.25	0.5	0.50
0.25	0.50	1.0	1.00
0.375	0.75	1.50	1.50
0.50	1.00	2.00	2.00
0.625	1.25	2.50	2.50
0.75	1.50	3.00	3.00
0.875	1.75	3.50	3.50
1.00	2.00	4.00	4.00
1.125	2.25	4.50	4.50
1.25	2.50	5.00	5.00

### Building Pressure Transducer

The Building Pressure Transducer is located behind the right hand damper door. The purpose of the transducer is to sense and convert the static pressure in the building to a 0 to 5 VDC signal. The DC voltage is then sent to the Unit Controller and compared against the *"BUILDING PRESSURE ACTIVE SETPOINT."* The transducer is factory wired, but pneumatic tubing must be field supplied and installed (*refer to SECTION 2 – INSTALLATION*). The Building Pressure Transducer measures differential pressure in the building and atmospheric pressure. When verifying transducer operation, the technician can insert a tee into the pneumatic tubing and connect a manometer to the tee to verify the pressure being applied to the transducer. Once this pressure is known, a comparison can be made of the building pressure vs. output VDC from the transducer. A practical and quick check of this transducer can also be accomplished by removing the pneumatic tubing lines from both the low and high side connections on the transducer. Since both of the inputs will now be exposed to the same pressure, the differential pressure will be zero, and the output 2.5VDC according to *Table 56 on page 182*.

### Return Fan Pressure Transducer

If the unit is order with the Return Fan Option the unit will have a Return Fan Pressure Transducer. The transducer is behind the right hand damper door and compares the pressure in the return air compartment to atmospheric pressure. The Unit Controller varies the speed of the Return Fan in order to maintain the correct

differential pressure in the return compartment. When verifying transducer operation, the technician can insert a tee into the pneumatic tubing and connect a manometer to the tee to verify the pressure being applied to the transducer. Once this pressure is known, a comparison can be made of the return compartment pressure vs. output VDC from the transducer. A practical and quick check of this transducer can also be accomplished by removing the pneumatic tubing lines from both the low and high side connections on the transducer. Since both of the inputs will now be exposed to the same pressure, the differential pressure will be zero, and the output 2.5VDC according to *Table 57 on page 183*.

**TABLE 56 - BUILDING PRESSURE TRANSDUCER OUTPUT**

DIFFERENTIAL INPUT PRESSURE - "W.C.	OUPTUT VOLTAGE - VDC
-0.50	0.00
-0.40	0.50
-0.30	1.00
-0.20	1.50
-0.10	2.00
0.00	2.50
0.10	3.00
0.20	3.50
0.30	4.00
0.40	4.50
0.50	5.00

**TABLE 57 - RETURN FAN PRESSURE TRANSDUCER OUTPUT**

DIFFERENTIAL INPUT PRESSURE - "W.C.	OUTPUT VOLTAGE - VDC
-1.00	0.00
-0.80	0.50
-0.60	1.00
-0.40	1.50
-0.20	2.00
0.00	2.50
0.20	3.00
0.40	3.50
0.60	4.00
0.80	4.50
1.00	5.00

**Discharge Pressure Transducer**

The discharge Pressure Transducer is located in the common discharge line of the tandem compressors for each refrigerant circuit. The purpose of this transducer is to sense and convert the discharge pressure into a DC voltage. The DC voltage is then sent to the Unit Controller where it is used to control the number of condenser fan when the unit is in cooling operation. The discharge pressure value, in PSIG, is displayed by the User Interface.

The Discharge Transducer has a range of 0 to 650 PSIG, with a linear output of 0 to 5 DC volts. *Table 58 on page 183* illustrates the DC voltage output from the transducer for a given discharge pressure.

**Suction Pressure Transducer**

The optional suction pressure transducer is located in the common suction line of the tandem compressors for each refrigerant circuit. The purpose of the transducer is to sense and convert the suction pressure to a DC voltage. The DC voltage is then sent to the Unit Controller where it is displayed by the User Interface. When this option is installed the Unit Controller will also calculate and display the Evaporator Superheat value for the system.

The Suction Transducer has a range of 0 to 400 PSIG, with a linear output of 0 to 5VDC from. *Table 58 on page 183* illustrates the DC voltage output from the transducer for a given suction pressure.

**TABLE 58 - PRESSURE TRANSDUCERS**

SUCTION TRANSDUCER		DISCHARGE TRANSDUCER	
PRESSURE PSIG	VOLTAGE VDC	PRESSURE PSIG	VOLTAGE VDC
0	0.5	0	0.5
25	0.75	32.5	0.7
50	1	65	0.9
75	1.25	97.5	1.1
100	1.5	130	1.3
125	1.75	162.5	1.5
150	2	195	1.7
175	2.25	227.5	1.9
200	2.5	260	2.1
225	2.75	292.5	2.3
250	3	325	2.5
275	3.25	357.5	2.7
300	3.5	390	2.9
325	3.75	422.5	3.1
350	4	455	3.3
375	4.25	487.5	3.5
400	4.5	520	3.7
		552.5	3.9
		585	4.1
		617.5	4.3
		650	4.5

**Humidity Sensors**

The humidity sensor outputs a 0 to 5VDC from in response to the relative humidity sensed. An outdoor air humidity sensor is used whenever the economizer is configured for single or dual enthalpy. A return air humidity sensor is used whenever the economizer is configured for dual enthalpy. A humidity sensor is also used to monitor the humidity in the space between the slab an *Table 59 on page 184* gives the relationship between the voltage output of the humidity sensor and the % relative humidity.

**CO<sub>2</sub> Sensor**

Two CO<sub>2</sub> sensors are used in conjunction with the "DEMAND VENTILATION" option. In "DEMAND VENTILATION" the Unit Control monitors the CO<sub>2</sub> level of the outdoor air and the CO<sub>2</sub> level in the conditioned space and varies the amount of ventilation air based on the relationship between these two values. *Table 60 on page 184* gives the VDC from output for a given CO<sub>2</sub> level.

**TABLE 59 - HUMIDITY SENSOR OUTPUTS**

% RELATIVE HUMIDITY	OUTPUT VOLTAGE VDC	% RELATIVE HUMIDITY	OUTPUT VOLTAGE VDC
5	0.25	55	2.75
10	0.50	60	3.00
15	0.75	65	3.25
20	1.00	70	3.50
25	1.25	75	3.75
30	1.50	80	4.00
35	1.75	85	4.25
40	2.00	90	4.50
45	2.25	95	4.75
50	2.50	100	5.00

**Furnace Status Input**

The Unit Controller monitors the operation of the Staged and Modulating Gas Heat sections and displays the status through the STATUS screen of the User Interface. The operation of each of the gas heat sections is monitored by a multiplexer installed in the gas heat section. When a gas heat section is energized, it sends a 24-volt signal to the multiplexer. The multiplexer takes the five “ON”/”OFF” inputs and converts them into a 0 to 5VDC signal that is sent to the Unit Controller. The Unit Controller then decodes this analog input and displays the furnace section status. *Table 61 on page 185* and *Table 62 on page 185* show the relationship between the DC voltage and the furnace operation status.

**TABLE 60 - CO2 SENSOR OUTPUT**

PPM CO2	OUTPUT VOLTAGE VDC	PPM CO2	OUTPUT VOLTAGE VDC
80	0.20	1120	2.80
160	0.40	1200	3.00
240	0.60	1280	3.20
320	0.80	1360	3.40
400	1.00	1440	3.60
480	1.20	1520	3.80
560	1.40	1600	4.00
640	1.60	1680	4.20
720	1.80	1760	4.40
800	2.00	1840	4.60
880	2.20	1920	4.80
960	2.40	2000	5.00
1040	2.60		



**TABLE 61 - FURNACE STATUS INPUT MODULATING GAS HEAT**

MIN VDC	MAX VDC	MODULATING FURNACE 1A STATUS	FURNACE 1A HIGH STATUS	FURNACE 2 STATUS	FURNACE 3 STATUS	FURNACE 1B STATUS
0.086	0.166	OFF	OFF	OFF	OFF	OFF
0.224	0.313	ON	OFF	OFF	OFF	OFF
0.361	0.461	OFF	ON	OFF	OFF	OFF
0.499	0.609	ON	ON	OFF	OFF	OFF
0.637	0.756	OFF	OFF	ON	OFF	OFF
0.774	0.904	ON	OFF	ON	OFF	OFF
0.912	1.051	OFF	ON	ON	OFF	OFF
1.050	1.199	ON	ON	ON	OFF	OFF
1.187	1.346	OFF	OFF	OFF	ON	OFF
1.325	1.494	ON	OFF	OFF	ON	OFF
1.463	1.641	OFF	ON	OFF	ON	OFF
1.600	1.789	ON	ON	OFF	ON	OFF
1.738	1.936	OFF	OFF	ON	ON	OFF
1.876	2.084	ON	OFF	ON	ON	OFF
2.013	2.231	OFF	ON	ON	ON	OFF
2.151	2.379	ON	ON	ON	ON	OFF
2.289	2.526	OFF	OFF	OFF	OFF	ON
2.426	2.674	ON	OFF	OFF	OFF	ON
2.564	2.821	OFF	ON	OFF	OFF	ON
2.702	2.969	ON	ON	OFF	OFF	ON
2.839	3.116	OFF	OFF	ON	OFF	ON
2.977	3.264	ON	OFF	ON	OFF	ON
3.115	3.411	OFF	ON	ON	OFF	ON
3.252	3.559	ON	ON	ON	OFF	ON
3.390	3.706	OFF	OFF	OFF	ON	ON
3.528	3.854	ON	OFF	OFF	ON	ON
3.665	4.001	OFF	ON	OFF	ON	ON
3.803	4.149	ON	ON	OFF	ON	ON
3.941	4.296	OFF	OFF	ON	ON	ON
4.078	4.444	ON	OFF	ON	ON	ON
4.216	4.592	OFF	ON	ON	ON	ON
4.354	4.739	ON	ON	ON	ON	ON

**TABLE 62 - FURNACE STATUS INPUT STAGED GAS HEAT**

MIN VDC	MAX VDC	FURNACE 1 STATUS	FURNACE 2 STATUS	FURNACE 3 STATUS
0.086	0.166	OFF	OFF	OFF
0.224	0.313	ON	OFF	OFF
0.361	0.461	OFF	ON	OFF
0.499	0.609	ON	ON	OFF
0.637	0.756	OFF	OFF	ON
0.774	0.904	ON	OFF	ON
0.912	1.051	OFF	ON	ON
1.050	1.199	ON	ON	ON

## FAULTS

A fault is defined as an abnormal condition, which results in the shutdown of an operating system or the complete unit. The presence of a fault condition indicates a situation in which possible damage to the unit may occur if the unit or system were allowed to continue to operate. There are four types of faults.

- **UNIT LOCKOUT** – The complete unit is shutdown and locked out. A manual reset is required to restart the unit after the fault has been corrected.
- **SYSTEM LOCKOUT** – One of the compressor systems or other component is shutdown and locked out. A manual reset is required to restart the system after the fault has been corrected.
- **UNIT AUTO RESET** – The complete unit is shutdown but the unit will restart automatically when the fault condition is cleared.
- **SYSTEM AUTO RESET** – One of the compressor systems or other component is shut down but the system or component will restart automatically when the fault condition is cleared.

A **UNIT LOCKOUT** can be reset by turning the “**LOCAL STOP**” switch OFF for 5 seconds and then back ON. If the cause of the lockout has been corrected the unit will reset and begin proper operation.

A **SYSTEM LOCKOUT** except for **COMPR # LOCKOUT** and **COMPR # LPCO SAFETY LOCKOUT** can be reset by turning the “**LOCAL STOP**” switch OFF for 5 seconds and then back ON. A **COMPR # LOCKOUT** and **COMPR # LPCO SAFETY LOCKOUT** must be reset by entering the **OPTION** key and the **COMPRESSOR SYSTEMS #** subsection, which has the lockout. Then use the up and down arrow key to go to **COMP SYS # STATUS**. The current status will be **LOCKOUT**. Press the check key (✓) and use the right arrow key to change **LOCKOUT** to **RUN**.

In addition to faults the User Interface will also display warnings. A warning is defined as an abnormal condition under which the unit continues to operate. Warnings will not require the unit to shut down; however, they may require the Unit Controller to disable certain functions that may result in the unit operating less efficiently or eliminate certain features.

*Table 65 on page 193* lists the faults / warnings that will be displayed under the **STATUS** and **HISTORY** keys of the User Interface. When a fault is present line two of the effected **STATUS** screen display (**UNIT-OVERALL STATUS**, **COMPRESSOR SYSTEM 1**,

**COMPRESSOR SYSTEM 2**, **COMPRESSOR SYSTEM 3**, **HEATING SYSTEM**, **ECONOMIZER SYSTEM**, **SUPPLY SYSTEM**, **EXHAUST SYSTEM**, **VENTILATION SYSTEM**, or **SENSOR / MISC STATUS**) will change nomenclature to indicate a **WARNING**, **SAFETY TRIP**, **SAFETY FAULT**, or **SAFETY LOCKOUT** is present. A fault / warning description, method of reset and conditions under which the information is displayed is also contained in the table. Additional information for each of the faults is contained under their respective section in *SECTION 5 – SEQUENCE OF OPERATION*.

When a fault is declared, the Unit Controller will record the time of occurrence, the date of occurrence, and a complete unit snapshot at the time of each occurrence in the **HISTORY** buffer. This data can be retrieved using the **HISTORY** key of the User Interface.

The **HISTORY** buffer stores the data from the last ten faults from the most recent (**HISTORY 01**) to the oldest (**HISTORY 10**). No fault **HISTORY** is eliminated once recorded other than being “pushed off” of the end of the list by a new fault when the buffer becomes full.

Warnings are only displayed in the **HISTORY** buffer while they are active. When the problem that generated the **WARNING** is corrected the record is removed from the buffer. The Unit Controller does not record the time of occurrence, the date of occurrence, or a complete unit snapshot at the time of occurrence for a **WARNING**.

The **HISTORY** buffer is password protected and a level 2 password must be entered in order to view the data.

When the **HISTORY** key is pressed, the password prompt will appear. After the proper level 2 password has been entered the screen will show the first active warning. If there are no active warnings present, the first fault will be displayed. If there are no faults in the **HISTORY** buffer, the screen will display “**NO FAULT.**” See *SECTION 6 – USER INTERFACE CONTROL CENTER* for additional information on how to navigate through the **HISTORY** menu.

In addition to the items listed in *Table 65 on page 193* the following items listed below are contained under the **HISTORY** key.

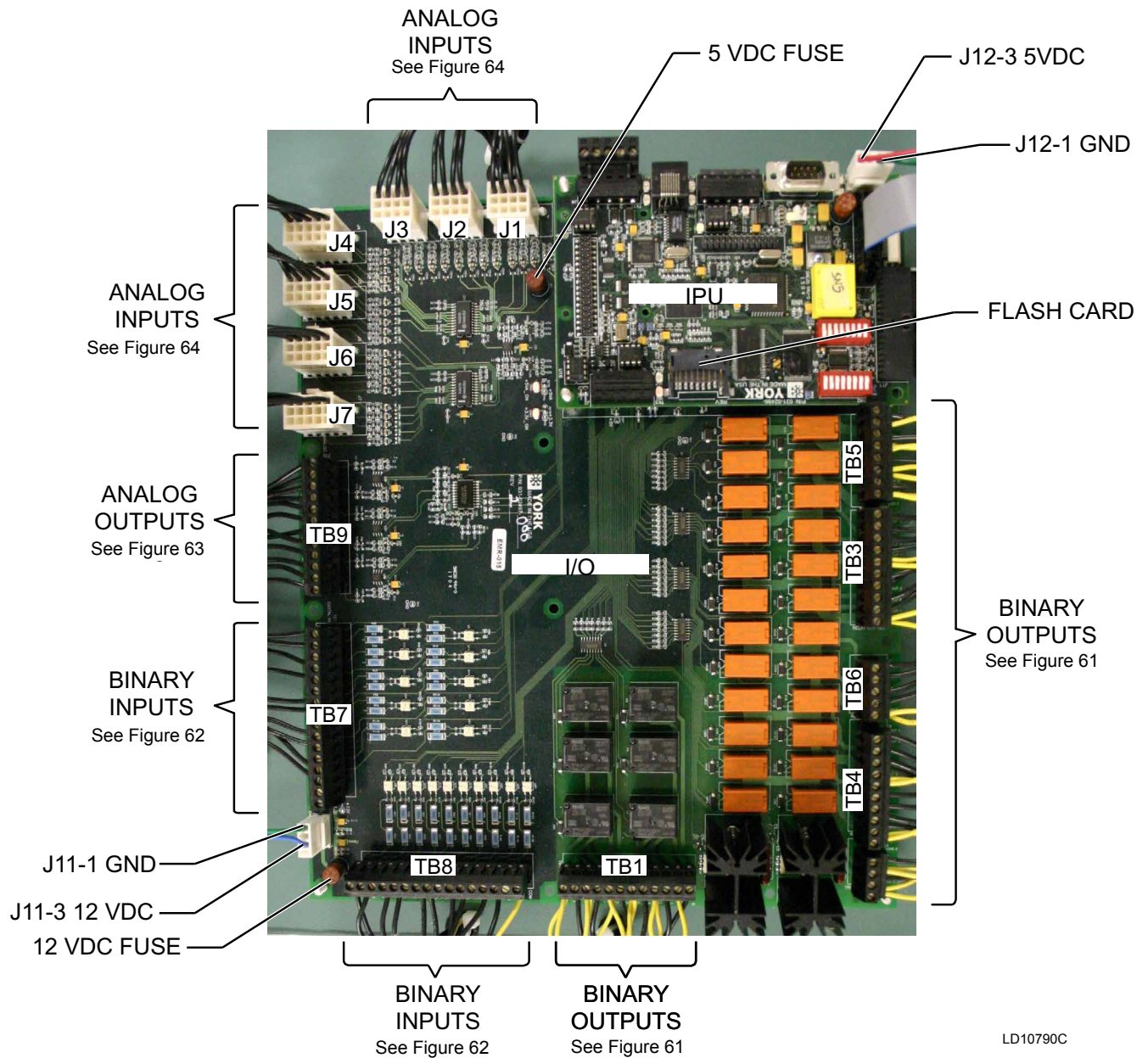
“**COMPRESSOR SYSTEM (1,2,OR 3) CLEAR**” - Whenever there is a compressor safety trip the Unit Controller initiates the “**COMPR STATUS CLEAR TIME (1,2, OR 3)**” timer. The Unit Control records the time it takes for the trip to clear. When the fault clears “**COMPRESSOR SYSTEM (1,2,OR 3) CLEAR**”

shows the time it took for the fault to clear in the HISTORY buffer.

“COMPRESSOR SYSTEM (1,2,OR 3)TIME OUT” – If the “COMPR STATUS CLEAR TIME (1,2, OR 3)” timer reaches 60 minutes a “COMPRESSOR SYSTEM (1,2,OR 3)TIME OUT” will be indicated in the HISTORY buffer. In most cases this indicates the compressor circuit over current protector opened. The compressor circuit over current protector is a manual reset device and the circuit would not reset in the required 60 minute time frame. The STATUS key will display the message “COMP SYS (1,2,OR 3) STA-

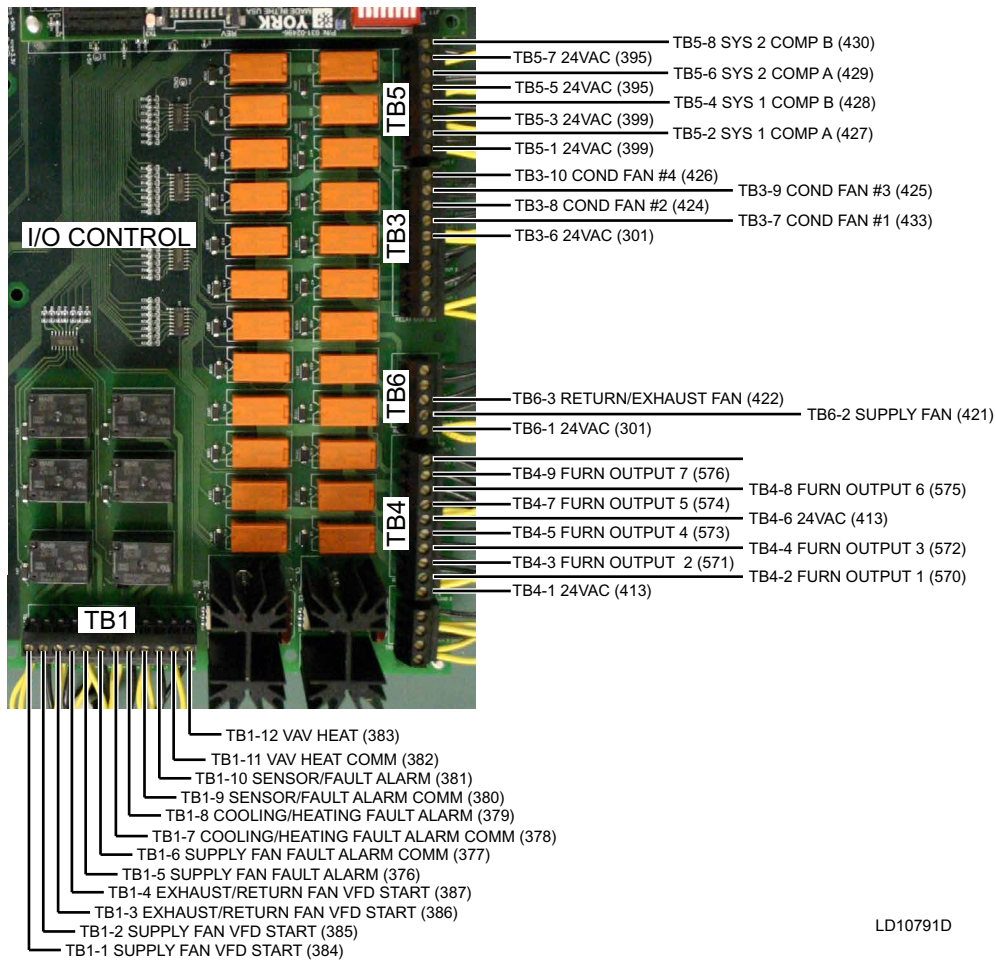
TUS” “SAFETY LOCKOUT.” The Unit Controller locks out the corresponding compressor system when a “COMPRESSOR SYSTEM (1,2,OR 3)TIME OUT” is declared.

“COMPR SYSTEM (1,2,OR 3) INHIBIT” – This WARNING indicates the compressor system safety circuit experienced a trip but reset prior to the exploration of the 60 minute reset time function. If the safety circuit does not reset in 60 minutes it will be replaced with a “COMPRESSOR SYSTEM (1,2,OR 3)TIME OUT” message.

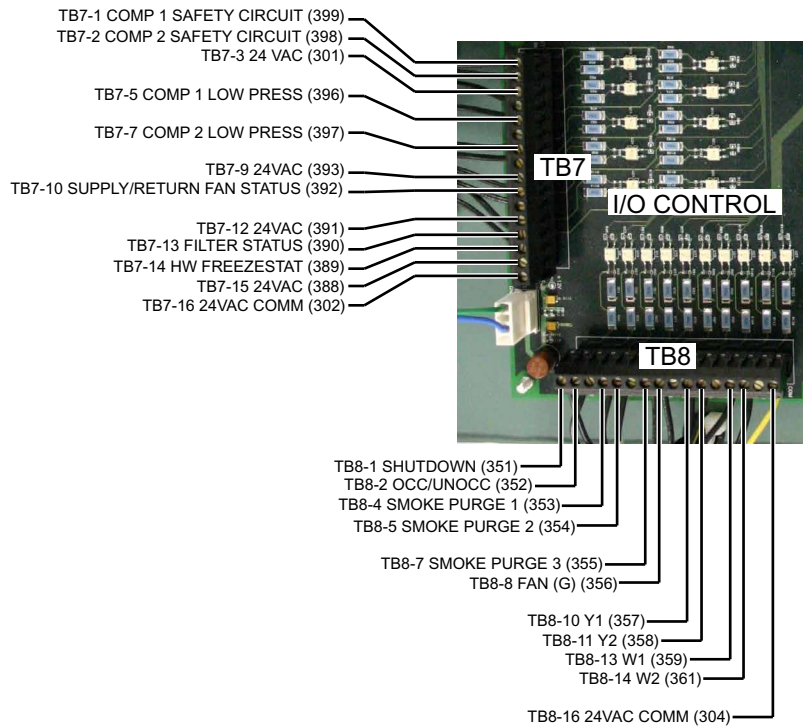


**FIGURE 60 - I/O CONTROL BOARD**

LD10790C

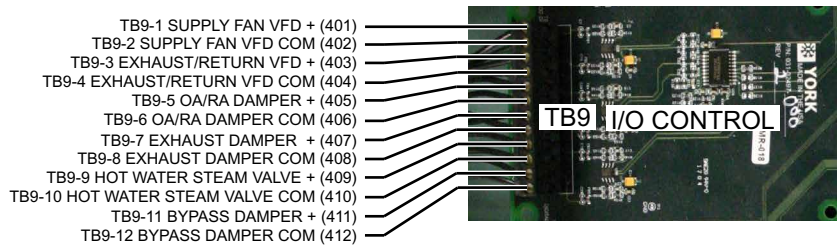


**FIGURE 61 - I/O CONTROL BOARD - BINARY OUTPUTS**



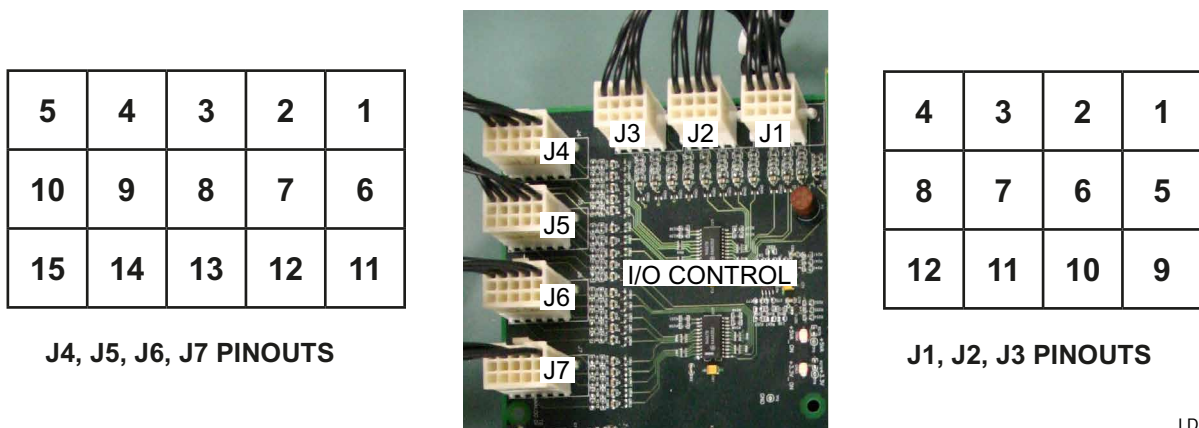
LD12945

**FIGURE 62 - I/O CONTROL BOARD - BINARY INPUTS**



LD13000

**FIGURE 63 - I/O CONTROL BOARD - ANALOG OUTPUTS**



LD10794

**FIGURE 64 - I/O CONTROL BOARD - ANALOG INPUTS (SEE TABLE 63 ON PAGE 190 FOR PIN OUTS)**

**TABLE 63 - I/O CONTROL BOARD - ANALOG INPUT PIN OUTS**

PIN NO.	SIGNAL
J1-1	INPUT SUPPLY AIR TEMP (308)
J1-5	SHIELD SUPPLY AIR TEMP
J1-9	REF SUPPLY AIR TEMP 5VDC (309)
J1-2	INPUT HEAT ENTER TEMP (310)
J1-6	SHIELD HEAT ENTER TEMP
J1-10	REF HEAT ENTER TEMP 5VDC (311)
J1-3	INPUT FLEX EVAP TEMP (312)
J1-7	SHIELD FLEX EVAP TEMP
J1-11	REF FLEX EVAP TEMP 5VDC (313)
J2-1	INPUT OUTSIDE AIR TEMP (329)
J2-5	SHIELD OUTSIDE AIR TEMP
J2-9	REF OUTSIDE AIR TEMP 5VDC (330)
J2-2	INPUT RETURN AIR TEMP (331)
J2-6	SHIELD RETURN AIR TEMP
J2-10	REF RETURN AIR TEMP 5VDC (332)
J2-3	INPUT OA HUM (333)
J2-7	COM OA HUM (334)
J2-4	INPUT RA HUM (335)
J2-8	COM RA HUM (336)
J3-1	INPUT SUCT TEMP SYS1 (347)
J3-5	SHIELD SUCT TEMP SYS1
J3-9	REF SUCT TEMP SYS1 5VDC (348)
J3-2	INPUT SUCT TEMP SYS2 (349)
J3-6	SHIELD SUCT TEMP SYS2
J3-10	REF SUCT TEMP SYS2 5VDC (350)
J3-4	INPUT SUCT PRESS SYS1 (317)
J3-8	COM SUCT PRESS SYS1 (318)
J3-12	REF SUCT PRESS SYS1 5VDC (319)
J4-1	INPUT SUCT PRESS SYS2 (320)
J4-6	COM SUCT PRESS SYS2 (321)
J4-11	REF SUCT PRESS SYS2 5VDC (322)
J4-3	INPUT DISCH PRESS SYS1 (323)
J4-8	COM DISCH PRESS SYS1 (324)

PIN NO.	SIGNAL
J4-13	REF DISCH PRESS SYS1 5VDC (325)
J4-4	INPUT DISCH PRESS SYS2 (326)
J4-9	COM DISCH PRESS SYS2 (327)
J4-14	REF DISCH PRESS SYS2 5VDC (328)
J5-1	INPUT GAS HEAT STATUS (542)
J5-6	COM GAS HEAT STATUS (543)
J5-11	REF GAS HEAT STATUS 5VDC (541)
J5-2	INPUT OA CO2 (343)
J5-7	COM OA CO2 (344)
J5-3	INPUT RA CO2 (345)
J5-8	COM RA CO2 (346)
J6-1	INPUT RETURN FAN PRESS (341)
J6-6	COM RETURN FAN PRESS (342)
J6-2	INPUT DUCT PRESS (337)
J6-7	COM DUCT PRESS (338)
J6-3	INPUT BLDG PRESS (339)
J6-8	COM BLDG PRESS (340)
J7-1	INPUT ZONE TEMP SENSOR (363)
J7-6	SHIELD ZONE TEMP SENSOR (364)
J7-11	REF ZONE TEMP SENSOR 5VDC (362)
J7-2	INPUT FLEXSYS SLAB SENSOR (366)
J7-7	SHIELD FLEXSYS SLAB SENSOR (367)
J7-12	REF FLEXSYS SLAB SENSOR 5VDC (365)
J7-3	INPUT FLEXSYS UNDER FLOOR HUM (368)
J7-8	COM FLEXSYS UNDER FLOOR HUM (369)
J7-4	INPUT SAT RESET (371)
J7-9	COM SAT RESET (372)
J7-14	REF SAT RESET 5VDC (370)
J7-5	INPUT DUCT STATIC RESET (374)
J7-10	COM DUCT STATIC RESET (375)
J7-15	REF DUCT STATIC RESET 5VDC (373)

**TABLE 64 - WARNING DESCRIPTION TABLE**

HISTORY SCREEN WORDING	DESCRIPTION	RESET	SHOW WHEN UNIT TYPE IS	STATUS SCREEN WORDING	FAULT OUTPUT TYPE
WRN-BUILDING PRS	BUILDING STATIC PRES more than 0.45 "W.C. OR less than -0.45 "W.C. FOR 10 SECONDS. POWER EXHAUST REVERTS TO NONE OR ON/OFF	AUTO RESET	POWER EXHAUST OTHER THAN NONE OR ON - OFF DAMPER	EXHAUST SYS STATUS WARNING	SENSOR/ MISC FAULT
WRN-CO2 SENSOR 1 OUTSIDE	OUTSIDE CO2 SENSOR OUT OF RANGE FOR more than or equal to 15 MINUTES	AUTO RESET	VENTILATION CONTROL EQUALS DEMAND	VENTILATION SYS STATUS WARNING	SENSOR/ MISC FAULT
WRN-CO2 SENSOR 2 INSIDE	OUTSIDE CO2 SENSOR OUT OF RANGE FOR more than or equal to 15 MINUTES	AUTO RESET	VENTILATION CONTROL EQUALS DEMAND	VENTILATION SYS STATUS WARNING	SENSOR/ MISC FAULT
WRN-COMPR SYSTEM * INHIBIT	SEE DESCRIPTION AT THE END OF THIS TABLE	AUTO RESET			COOLING HEATING FAULT
WRN-DIRTY FILTER 1	THE FILTER STATUS INPUT IS CLOSED FOR more than or equal to 1 MINUTE	AUTO RESET	DIRTY FILTER SWITCH IS INSTALLED	FILTER STATUS CHANGE	SENSOR/ MISC FAULT
WRN-DISCHARGE PRS SENSOR*	THE DISCHARGE PRESURE FOR THAT SYSTEM IS OUT OF RANGE FOR more than or equal to 10 SECONDS	AUTO RESET	PRESS TRANS PKG IS ON FOR THE SYSTEM	SENSOR/ MISC STATUS WARNING	SENSOR/ MISC FAULT
WRN-DUCT PRS XDCCR	SUPPLY FAN OUTPUT ON, SUPPLY FAN STATUS MUST BE RUNNING FOR 5 MINUTES, STATIC PRESS CURRENT less than or equal to (0.333 X DUCT STATIC PRESS ACTIVE SP) FOR 30 SECONDS	AUTO RESET	UNIT TYPE IS VAV OR FLEXSYS	SUPPLY SYS STATUS WARNING	FAN FAULT
WRN-EXHAUST FAN	THE EXHAUST FAN OUTPUT IS ON FOR 45 SECONDS AND THE RUN VERIFICATION INPUT IS LOW (OPEN) FOR 10 SECONDS	AUTO RESET	POWER EXHAUST OTHER THAN NONE	EXHAUST SYSTEM STATUS WARNING	SENSOR/ MISC FAULT
WRN-FREEZESTAT TRIP	THE HW/STEAM FREEZSTAT CIRCUIT GOES LOW (OPEN) BUT GOES HIGH (CLOSED) WITHIN 5 MINUTES	AUTO RESET	HEATING SYSTEM TYPE EQUALS HOT WATER STEAM	SENSOR/ MISC STATUS WARNING	COOLING HEATING FAULT
WRN-FURNACE MULTIPLEXER FAULT	ON MODULATING GAS THE HEAT, BINARY OUTPUTS DO NOT MATCH THE GAS FURNACE STATUS INPUT. SEE <i>Table 61 on page 185</i> OR NO FURNACE STATUS INPUT ON STAGED GAS	AUTO RESET	HEATING SYSTEM TYPE EQUALS MODULATING GAS OR STAGED GAS	SENSOR/ MISC STATUS WARNING	COOLING HEATING FAULT
WRN-GAS FURNACE	THE HEAT BINARY OUTPUTS DO NOT MATCH THE GAS FURNACE STATUS INPUT. SEE <i>Table 62 on page 185</i>	AUTO RESET	HEATING SYSTEM TYPE EQUALS STAGED GAS		COOLING HEATING FAULT

\* CAN BE 1, 2, OR 3 # CAN BE A OR B

**TABLE 64 - WARNING DESCRIPTION TABLE (CONT'D)**

HISTORY SCREEN WORDING	DESCRIPTION	RESET	SHOW WHEN UNIT TYPE IS	STATUS SCREEN WORDING	FAULT OUTPUT TYPE
WRN-HET SENSOR	THE HEAT ENTERING SENSOR IS OUT OF RANGE FOR more than or equal to 10 SECONDS	AUTO RESET	HEATING SYSTEM TYPE IS STAGED GAS OR ELECTRIC	SENSOR/ MISC STATUS WARNING	SENSOR/ MISC FAULT
WRN-HIGH DP UNLOAD *#	BOTH COMPRESSOR ARE ON FOR THE SYSTEM AND THE DISCHARGE PRESS IS more than or equal to TO THE SYSTEM UNLOADING PRESSURE FOR 10 SECONDS	AUTO RESET	PRESS TRANS PKG IS ON FOR THE SYSTEM	SENSOR/ MISC STATUS WARNING	SENSOR/ MISC FAULT
WRN-LOW AMBIENT TEMP *	THE OUTDOOR TEMP IS less than or equal to THE MECH COOL LOCKOUT TEMP	AUTO RESET	LOW AMBIENT PKG IS NOT INSTALLED FOR THE SYSTEM	COMP SYS * STATUS LOW AMB INHIBIT	SENSOR/ MISC FAULT
WRN-LOW SUCTION TEMP *#	THE SUCTION TEMP IS LEES THAN THE SUCTION TEMP LOW LIMIT FOR 10 CONTINUOUS SECONDS	AUTO RESET		COMP SYS * STATUS SUCTION TEMP UNL # ON	SENSOR/ MISC FAULT
WRN-OA FLOW PRS 1	REFER TO AIR MEASUREMENT STATION SENSOR FAULTS IN SECTION 5 OF THE MANUAL	LOCKS OUT THE AIR MEASURING STATION	DAMPER HARDWARE IS MINIMUM IAQ, FULL IAQ, 1/3-2/3 IAQ, TEK AIR FULL IAQ	SENSOR/ MISC STATUS WARNING	SENSOR/ MISC FAULT
WRN-OA FLOW PRS 2	REFER TO AIR MEASUREMENT STATION SENSOR FAULTS IN SECTION 5 OF THE MANUAL	LOCKS OUT THE AIR MEASURING STATION	DAMPER HARDWARE IS 1/3 - 2/3 IAQ	SENSOR/ MISC STATUS WARNING	SENSOR/ MISC FAULT
WRN-OUTSIDE AIR RH	OUTSIDE AIR TEMP more than or equal to 32 °F FOR 10 SECONDS OUTDOOR AIR HUMIDITY less than 5% FOR 10 SECONDS	AUTO RESET	ECONO INSTALLED SINGLE ENTHALPY OR DUAL ENTHALPY	SENSOR/ MISC STATUS WARNING	SENSOR/ MISC FAULT
WRN-RETURN AIR RH	RETURN AIR TEMP more than or equal to 32 °F FOR 10 SECONDS RETURN AIR HUMIDITY less than 5% FOR 10 SECONDS	AUTO RESET	ECONO INSTALLED DUAL ENTHALPY	SENSOR/ MISC STATUS WARNING	SENSOR/ MISC FAULT
WRN-RETURN FAN XDCR	SUPPLY FAN OUTPUT IS ON AND RETURN FAN PRESS CURRENT less than -0.95 "W.C. OR more than 0.95 "W.C. FOR 30 SECONDS OR SUPPLY FAN OUTPUT IS OFF AND RETURN FAN PRESSURE CURRENT less than -0.1 "W.C. OR more than 0.1 "W.C. FOR 5 MINUTES	AUTO RESET	POWER EXHAUST TYPE IS RETURN FAN W/EXH OR RETURN FAN W/O EXH	SUPPLY SYS STATUS WARNING	FAN FAULT

\* CAN BE 1, 2, OR 3 # CAN BE A OR B



**TABLE 64 - WARNING DESCRIPTION TABLE (CONT'D)**

HISTORY SCREEN WORDING	DESCRIPTION	RESET	SHOW WHEN UNIT TYPE IS	STATUS SCREEN WORDING	FAULT OUTPUT TYPE
WRN-SLAB TEMP SENSOR	UDERFLOOR SLAB TEMP SENSOR IS OUT OF RANGE FOR more than or equal to 10 SECONDS	AUTO RESET	UNIT TYPE IS FLEXSYS AND DEW POINT RESET IS USER ENABLED	SENSOR/ MISC STATUS WARNING	SENSOR/ MISC FAULT
WRN-SUCTION PRS SENSOR *	SUCTION PRESSURE OUT OF RANGE FOR more than or equal to 10 SECONDS	AUTO RESET	PRESS TRANS PKG IS ON FOR THE SYSTEM	SENSOR/ MISC STATUS WARNING	SENSOR/ MISC FAULT
WRN-SUCTION TEMP SENSOR * #	SUCTION TEMPERATURE SENSOR IS OUT OF RANGE FOR more than or equal to 10 SECONDS	AUTO RESET		SENSOR/ MISC STATUS WARNING	SENSOR/ MISC FAULT
WRN-UNDER FLOOR RH SENSOR	UDERFLOOR AIR HUMIDITY IS less than 5% FOR more than or equal to 5 MINUTES	AUTO RESET	UNIT TYPE IS FLEXSYS AND DEW POINT RESET IS USER ENABLED	SENSOR/ MISC STATUS WARNING	SENSOR/ MISC FAULT

\* CAN BE 1, 2, OR 3 # CAN BE A OR B

**TABLE 65 - FAULT AUTO - RESET**

HISTORY SCREEN WORDING	DESCRIPTION	RESET	HOW WHEN UNIT TYPE IS	STATUS SCREEN WORDING	FAULT OUTPUT TYPE
AUTO RESET-COMPRESSOR SYSTEM * CLEAR	SEE DESCRIPTION BELOW	AUTO RESET			
AUTO RESET-COMPRESS SYSTEM * TRIP 1	THE SAFETY INPUT CHAIN IS OPEN (FAULTED) FOR MORE THAN TWO SECONDS WITH EITHER OR BOTH COMPRESSOR OF THE SYSTEM ON AND THIS IS THE FIRST TRIP IN A 120 MINUTE SPAN	AUTO RESET		COMP SYSTEM * STATUS SAFVETY TRIP	COOLING HEATING FAULT
AUTO RESET COMPRESSOR SYSTEM * TRIP 2	THE SAFETY INPUT CHAIN IS OPEN (FAULTED) FOR MORE THAN TWO SECONDS WITH EITHER OR BOTH COMPRESSOR OF THE SYSTEM ON AND THIS IS THE SECOND TRIP IN A 120 MINUTE SPAN	AUTO RESET		COMP SYSTEM * STATUS SAFETY TRIP	COOLING HEATING FAULT
AUTO RESET-LOW SUCTION TEMP	EITHER IS COMPRESSOR ON AND THE TEMPERATURE - SUCTION IS LESS THAN OR EQUAL TO THE SUCTION LOW LIMIT FOR 10 CONTINUOUS SECONDS AND AFTER THE COMPRESSOR WAS TURNED OFF THE TEMPERATURE DID NOT RISE ABOVE THE LIMIT.	AUTO RESET		COMP SYSTEM * STATUS SAFETY FAULT	SENSOR/ MISC FAULT

\* CAN BE 1, 2, OR 3

**TABLE 65 - FAULT AUTO - RESET (CONT'D)**

HISTORY SCREEN WORDING	DESCRIPTION	RESET	HOW WHEN UNIT TYPE IS	STATUS SCREEN WORDING	FAULT OUTPUT TYPE
AUTO RESET- LPCO * TRIP 1	THE LOW PRESSURE CUTOUT INPUT CHAIN IS OPEN (FAULTED) FOR MORE THAN TWO SECONDS WITH EITHER OR BOTH COMPRESSOR OF THE SYSTEM ON AND THIS IS THE FIRST TRIP IN A 120 MINUTE SPAN	AUTO RESET		COMP SYSTEM * STATUS SAFVETY TRIP	COOLING HEATING FAULT
AUTO RESET- LPCO * TRIP 2	THE LOW PRESSURE CUTOUT INPUT CHAIN IS OPEN (FAULTED) FOR MORE THAN TWO SECONDS WITH EITHER OR BOTH COMPRESSOR OF THE SYSTEM ON AND THIS IS THE SECOND TRIP IN A 120 MINUTE SPAN	AUTO RESET		COMP SYSTEM * STATUS SAFVETY TRIP	COOLING HEATING FAULT
AUTO RESET - MSAT SENSOR	MS SUPPLY AIR TEMP CURRENT SENSOR IS OUT OF RANGE FOR MORE THAN OR EQUAL TO 10 SECONDS.	AUTO RESET	UNIT TYPE IS FLEXSYS	SENSOR/ MISC STATUS SAFETY LOCKOUT	SENSOR/ MISC FAULT
AUTO RESET - POWER FAIL	POWER IS LOST WHEN THE UNIT OPERATING STATE IS RUN	AUTO RESET			
AUTO RESET - RAT SENSOR	RETURN AIR TEMP CURRENT SENSOR IS OUT OF RANGE FOR MORE THAN OR EQUAL TO 10 SECONDS	AUTO RESET		SENSOR/ MISC STATUS SAFETY FAULT	SENSOR/ MISC FAULT
AUTO RESET - REMOTE I/O COMM	NO COMMUNICATION FROM THE I/O BOARD FOR MORE THAN OR EQUAL TO 5 SECONDS	AUTO RESET			SENSOR/ MISC FAULT
AUTO RESET - STAGED INPUT	THE CONTROL HAS A COOLING AND HEATING THERMOSTAT INPUT AT THE SAME TIME FOR A PERIOD GREATER THAN 10 SECONDS	AUTO RESET		SENSOR/ MISC STATUS SAFETY LOCKOUT	SENSOR/ MISC FAULT
AUTO RESET - ZONE TEMP SENSOR	ZONE TEMP CURRENT SENSOR IS OUT OF RANGE FOR MORE THAN OR EQUAL TO 10 SECONDS	AUTO RESET	UNIT TYPE IS VAV AND NIGHT SET BACK IS USER ENABLED OR UNIT TYPE IS SET TO CV AND THE CONTROL METHOD IS SET TO ZONE SENSOR HARDWIRED	SENSOR/ MISC STATUS SAFETY LOCKOUT	SENSOR/ MISC FAULT

\* CAN BE 1, 2, OR 3

**TABLE 66 - FAULTS LOCKOUT**

HISTORY SCREEN WORDING	DESCRIPTION	RESET	SHOW WHEN UNIT TYPE IS	STATUS SCREEN WORDING	FAULT OUTPUT TYPE
LOCKOUT-COMPRESSOR SYSTEM * TIME OUT	SEE BELOW	SYSTEM LOCKOUT		COMP SYSTEM * - SAFETY LOCKOUT	COOLING HEATING FAULT
LOCKOUT - COMPRESSOR SYSTEM *	HIGH PRESS SW, COMP MOTOR PROTECTOR, OR OVERCURRENT PROTECTOR OPEN - 3 TIMES IN 120 MINUTES ON COMP SYSTEM *	SYSTEM LOCKOUT		COMP SYSTEM * - SAFETY LOCKOUT	COOLING HEATING FAULT
LOCKOUT - HGRH FAULT 1	HGRH SYSTEM IS INACTIVE, A COMP FROM CKT 2 IS ON, AND THE CURRENT SAT IS GREATER THAN/EQUAL TO THE CURRENT EVAP AIR TEMP + 8.0 °F	SYSTEM LOCKOUT	HGRH IS INSTALLED	COMP SYSTEM 2 - SAFETY LOCKOUT	COOLING HEATING FAULT
LOCKOUT - HGRH FAULT 2	HGRH SYSTEM IS ACTIVE, THE HGRH VALVE POSITION IS GREATER THAN 50%, AND THE CURRENT SAT IS LESS THAN/EQUAL TO THE CURRENT EVAP AIR TEMP + 8.0 °F	SYSTEM LOCKOUT	HGRH IS INSTALLED	COMP SYSTEM 2 - SAFETY LOCKOUT	COOLING HEATING FAULT
LOCKOUT - HGRH FAULT 3	HGRH SYSTEM IS INSTALLED, A COMP FROM CKT 2 IS ON, AND THE CKT 2 DISCH PRESS IS GREATER THAN/ EQUAL TO 90% OF THE SYSTEM UNLOADING PRESSURE	SYSTEM LOCKOUT	HGRH IS INSTALLED	COMP SYSTEM 2 - SAFETY LOCKOUT	COOLING HEATING FAULT
LOCKOUT-HIGH DUCT PRESSURE	DUCT STATIC PRESS CURRENT .+ DUCT STATIC OVER PRESSURE	UNIT LOCKOUT	UNIT TYPE IS VAV OR FLEXSYS	SUPPLY SYS STATUS SAFETY LOCKOUT	FAN FAULT
LOCKOUT - HOT WATER FREEZE	THE HYDRONIC FREEZE STAT SWITCH REMAINED OPEN MORE THAN OR EQUAL TO 5 MINUTES	UNIT LOCKOUT	HEAT TYPE HOT WATER / STEAM	HEATING SYS STATUS - SAFETY LOCKOUT	COOLING HEATING FAULT
LOCKOUT-LPCO	LOW PRESSURE CUTOUT OPEN - 3 TIMES IN 120 MINUTES ON COMPR SYSTEM *	SYSTEM LOCKOUT		COMP SYSTEM * - SAFETY LOCKOUT	COOLING HEATING FAULT
LOCKOUT - MANUAL STOP *	THE COMPRESSOR SYSTEM HAS BEEN PLACED IN THE STOP MODE EITHER THROUGH THE USER INTERFACE OR BY A COMMUNICATED INPUT	SYSTEM LOCKOUT		COMP SYS * STATUS DISABLED	

\* CAN BE 1, 2, OR 3

*“WRN - COMP SYSTEM \* INHIBIT”* - This WARNING indicates the compressor system safety circuit experienced a trip but reset prior to the expiration of the 60 minute reset time function. If the safety circuit does not reset in 60 minutes it will be replaced with a *“LOCKOUT - COMPRESSOR SYSTEM \* TIME OUT”* message.

*“AUTO RESET - COMPRESSOR SYSTEM \* CLEAR”* - When ever there is a compressor safety trip the Primary Unit Controller initiates the *“COMPR STATUS CLEAR TIME \*\*”* timer. The Primary Unit Control records the time it takes for the trip to clear. When the fault clears *“COMPRESSOR SYSTEM \* CLEAR”* shows the time it took for the fault to clear in the HISTORY buffer.

*“LOCKOUT-COMPRESSOR SYSTEM \* TIME OUT”* – If the *“COMPR STATUS CLEAR TIME \*\*”* timer reaches 60 minutes a *“LOCKOUT - COMPRESSOR SYSTEM \* TIME OUT”* will be indicated in the HISTORY buffer.

**TABLE 66 - FAULTS LOCKOUT (CONT'D)**

HISTORY SCREEN WORDING	DESCRIPTION	RESET	SHOW WHEN UNIT TYPE IS	STATUS SCREEN WORDING	FAULT OUTPUT TYPE
LOCKOUT - MANUAL UNIT STOP	THE UNIT IS SHUT DOWN THROUGH THE SHUT DOWN SWITCH ON THE UNIT OR BY AN EXTERNAL HARDWIRED OR COMMUNICATED INPUT	UNIT LOCKOUT		UNIT - OVERALL STATUS LOCAL STOP	
LOCKOUT - OAT SENSOR	OUTSIDE AIR TEMP SENSOR IS OUT OF RANGE FOR MORE THAN OR EQUAL TO 10 SECONDS	UNIT LOCKOUT		COMP SYS * STATUS SAFETY LOCKOUT; ECONO SYS STATUS SAFETY LOCKOUT	SENSOR/ MISC FAULT
LOCKOUT - SAT SENSOR	SUPPLY AIR TEMP CURRENT SENSOR IS OUT OF RANGE FOR more than or equal to 10 SECONDS	UNIT LOCKOUT	UNIT TYPE IS CONSTANT VOLUME OR VARIABLE AIR VOLUME		SENSOR/ MISC FAULT
LOCKOUT-SUPPLY FAN	SUPPLY FAN STATUS IS LOW AND TIME FROM START more than or equal to 30 SEC UNIT LOCKOUT ON THE RETURN FAN STATUS IS LOW AND TIME FROM START more than or equal to 30 SEC UNIT LOCKOUT	UNIT LOCKOUT		UNIT - OVERALL STATUS UNIT LOCKOUT	FAN FAULT

\* CAN BE 1, 2, OR 3

**"WRN - COMP SYSTEM \* INHIBIT"** - This WARNING indicates the compressor system safety circuit experienced a trip but reset prior to the expiration of the 60 minute reset time function. If the safety circuit does not reset in 60 minutes it will be replaced with a **"LOCKOUT - COMPRESSOR SYSTEM \* TIME OUT"** message.

**"AUTO RESET - COMPRESSOR SYSTEM \* CLEAR"** - When ever there is a compressor safety trip the Primary Unit Controller initiates the **"COMPR STATUS CLEAR TIME \*\*"** timer. The Primary Unit Control records the time it takes for the trip to clear. When the fault clears **"COMPRESSOR SYSTEM \* CLEAR"** shows the time it took for the fault to clear in the HISTORY buffer.

**"LOCKOUT-COMPRESSOR SYSTEM \* TIME OUT"** – If the **"COMPR STATUS CLEAR TIME \*\*"** timer reaches 60 minutes a **"LOCKOUT - COMPRESSOR SYSTEM \* TIME OUT"** will be indicated in the HISTORY buffer.

## MULTI MEDIA CARD

The Unit Controller is made up of two separate control boards, the PLUG IN I/O board and the IPU board. All the digital and analog inputs and outputs are connected to the PLUG IN I/O control. All the system logic is contained on the IPU board. The IPU board mounts on top of the PLUG IN I/O board and handles the communication between the PLUG IN I/O board and the User Interface. Another feature of this control system is the availability to connect a MULTI MEDIA CARD to the IPU board. The MULTI MEDIA CARD allows operational data to be continuously saved and used for the diagnosis of unit operating problems.

A MULTI MEDIA CARD is similar to a hard drive in a PC. It has a directory structure and files are saved on it. The difference between a hard drive and the MULTI MEDIA CARD is that the MULTI MEDIA CARD is made of non-volatile flash memory. This allows the MULTI MEDIA CARD to be removed from the IPU board and placed in a PC for data analysis without the loss of any data.

The MULTI MEDIA CARD is considered a Service tool and as such is controlled through the SERVICE key of the User Interface. Entry into the SERVICE screen requires a Level 2 password.

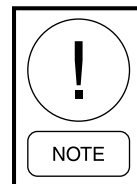
Data is continuously stored to the MULTI MEDIA CARD in root and subdirectories. The root directories are set up by month and year, under each of the root directories are subdirectories for each day. For example the data for January 11, 2005 would be stored in a root directory identified by Rm200501, the year followed by the month. The subdirectory for this day would be identified as 20050111.csv, the year followed by the month, followed by the day. Each of these files contains all the data monitored for the day specified by the file name.

All connected Analog Inputs, Analog Outputs, Digital Inputs, Digital Outputs, Serial Data and Derived Data will be collected. The data will be collected once every 5 seconds and stored in the same order as in the History buffer. Each line of data will be timed and date stamped. Each file will include a header line detailing what data is stored in each column.

The collected data can be analyzed using a PC. The MULTI MEDIA CARD can be inserted into a MULTI MEDIA CARD reader attached to the PC. The data can be analyzed using Excel or another data analysis tool.

To install or remove the MULTI MEDIA CARD from the IPU board “*DATA LOG FORMAT*” must be set to OFF. This is done through the SERVICE screen of the User Interface. When the MULTI MEDIA CARD is installed the operation can be programmed to “*UNCOMPRESSED*” in which case data will be recorded every 5 seconds or “*SKIP UNCHANGED*” which is the same as “*UNCOMPRESSED*” except values are only saved when they change.

If an error occurs when writing to the MULTI MEDIA CARD, “*DATA LOG ERROR STATE*” and “*DATA LOG ERROR DETAIL*” will appear under the SERVICE screen. “*DATA LOG ERROR STATE*” indicates what operation failed and “*DATA LOG ERROR DETAIL*” will give the error code from the operation. *Table 67 on page 197* gives a description of the “*DATA LOG ERROR STATE*” and *Table 68 on page 198* gives a description of the “*DATA LOG ERROR DETAIL*.”



***The SD card cannot exceed 2 MB for data logging or software updates. Not all SD cards are compatible with the IPU system.***

**TABLE 67 - DATA LOG ERROR STATE**

DATA LOG ERROR STATE	AN ERROR OCCURRED WHEN DOING THIS:
1	Mounting the flash card
2	Opening the root directory
3	Reading the root directory
4	Closing the root directory
5	Opening a sub-directory
6	Reading a sub-directory
7	Closing a sub-directory
8	Deleting an old directory
11	Creating a directory
14	Creating a file
15	Open a file
16	Write a file
17	Delete a file
18	Close a file

**TABLE 68 - DATA LOG ERROR LOG DETAIL**

<b>DATA LOG ERROR DETAIL</b>	<b>THIS ERROR OCCURRED:</b>
1	Not permitted
2	No such entity
3	No such process
4	Operation interrupted
5	I/O error
6	Bad file handle
11	Try again later
12	Out of memory
16	Resource busy
19	No such device
20	Not a directory
21	Is a directory
22	Invalid argument
23	Too many open files in system
27	File too large
28	No space left on device
29	Illegal seek
30	Read-only file system
60	File name too long

## NOTES



P.O. Box 1592, York, Pennsylvania USA 17405-1592

Copyright © by Johnson Controls 2017

Form 100.50-NOM5 (917)

Issue Date: September 28, 2017

Supersedes: 100.50-NOM5 (517)

800-861-1001

[www.johnsoncontrols.com](http://www.johnsoncontrols.com)

Subject to change without notice. Printed in USA

ALL RIGHTS RESERVED